



# Technical specification for Small Form Factor Pluggable (SFP)

OC-48 (2488.32Mbps)

Sumitomo Part Number	Function
SCP6G28-GL-# W E	SR, 1310nm, 2km
SCP6G08-GL-# W E	IR-1, 1310nm, 15km



Sumitomo Electric reserves the right to make changes in this specification without prior notice.  
Sumitomo Electric Industries, Ltd. and ExceLight Communications, Inc. have been granted license to the following patents under a license agreement with Finisar corporation: US5,019,769, US6,439,918 B1

**#Safety Precaution Symbols** This specification uses various picture symbols to prevent possible injury to operator or other persons or damage to properties for appropriate use of the product. The symbols and definitions are as shown below. Be sure to be familiar with these symbols before reading this specification.

 **Caution** Wrong operation without following this instruction may lead to human injury or property damage.

 **Warning** Wrong operation without following this instruction may lead to human death or serious injury.

Examples of picture symbols



indicates prohibition of actions. Action details are explained thereafter.

 indicates compulsory actions or instructions. Action details are explained thereafter.

## 1 General

Features and applications of SCP6G28/SCP6G08 are listed below.

### Features

- \* RoHS-6 Compliant.
- \* Compliant with SFP MSA.
- \* SFF-8472 rev.9 compliant diagnostic monitoring implemented.
- \* Power Supply Voltage                      Single +3.3V
- \* Compact Package Size                     57.5 X 13.9 X 8.6 mm
- \* Electrical Interface                        AC coupled for DATA, LVTTTL for Tx Disable and open collector output for LOS and Tx Fault. Circuit ground is internally isolated from frame ground.
- \* Connector Interface                        LC Duplex
- \* Serial ID Functionality
- \* Alarm and Warning Flags
- \* Bail type Actuator

## 2 Block diagram

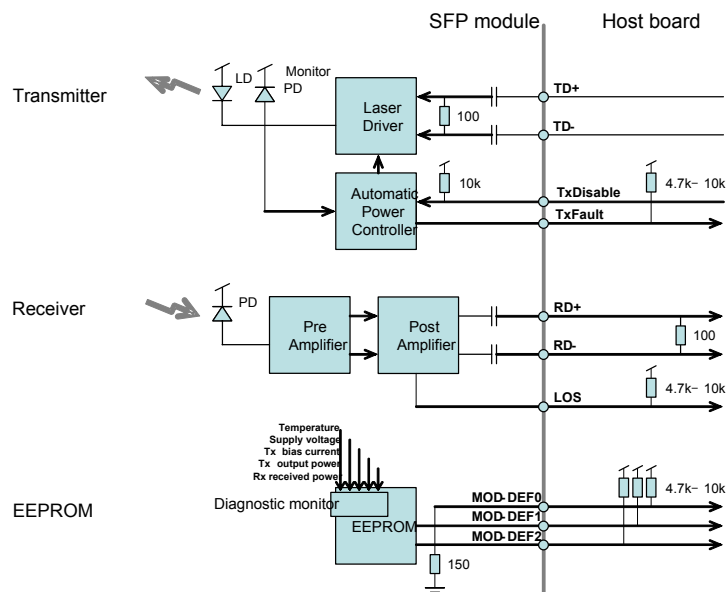
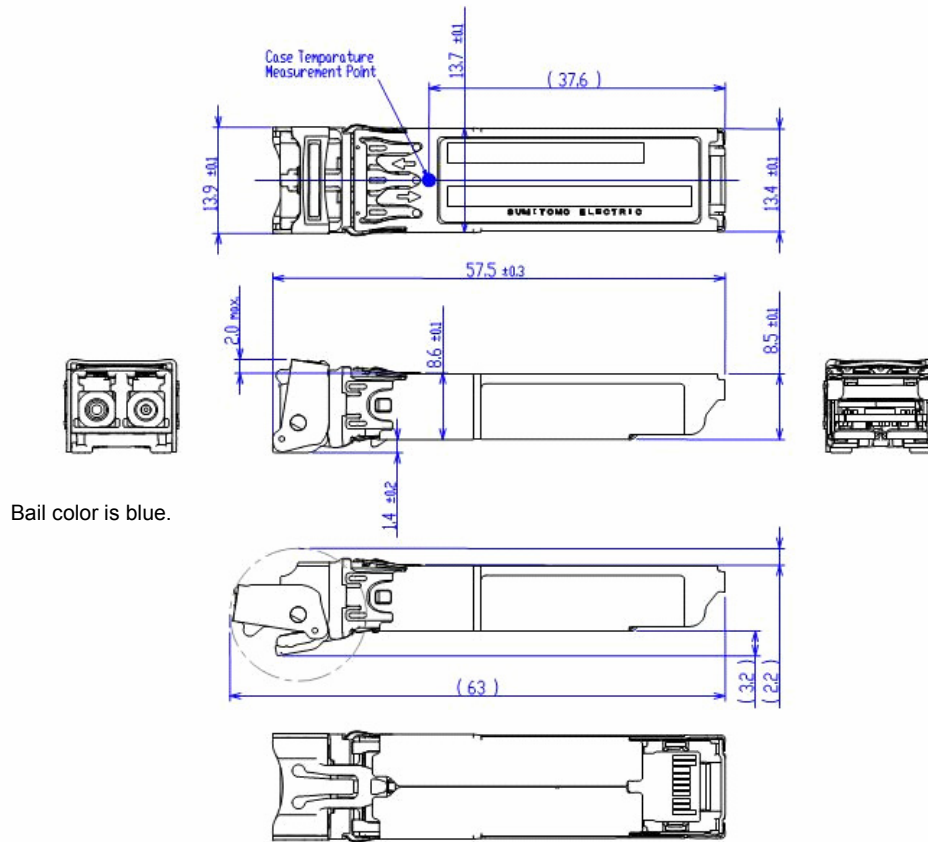

Figure 1. Block diagram

<b>Caution</b>
Do not disassemble this product. Otherwise, failure, electrical shock, overheating or fire may occur.

### 3 Package dimensions



Note1 All Dimensions in mm

Note2 Dimensions with parentheses indicate the bail and latch release position

**Figure 2.** Package dimensions

## 4 Pin assignment and function

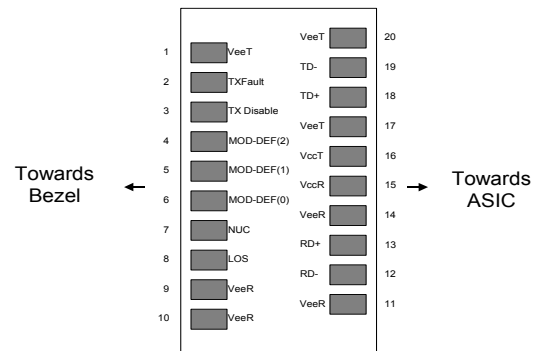

Figure 3. Pin assignment

Pin number	Name	Function	Plug sequence*	Note
1	VeeT	Transmitter ground	1	
2	TXFault	Transmitter fault indication	3	
3	TXDisable	Transmitter disable input	3	Module disables on high or open
4	MOD-DEF2	Module definition 2	3	2 wire serial ID and interface
5	MOD-DEF1	Module definition 1	3	2 wire serial ID and interface
6	MOD-DEF0	Module definition 0	3	Grounded internally via 100ohm
7	NUC	No user connection	3	Reserved for future use
8	LOS	Loss of signal indication	3	
9	VeeR	Receiver ground	1	
10	VeeR	Receiver ground	1	
11	VeeR	Receiver ground	1	
12	RD-	Negative receiver Data out	3	
13	RD+	Positive receiver Data out	3	
14	VeeR	Receiver ground	1	
15	VccR	Receiver power	2	
16	VccT	Transmitter power	2	
17	VeeT	Transmitter ground	1	
18	TD+	Positive transmitter Data in	3	
19	TD-	Negative transmitter Data in	3	
20	VeeT	Transmitter ground	1	

\*Plug sequence: Pin engagement sequence during hot plugging.

**TxFault** TxFault is an open collector output that shall be pulled up with a 4.7k to 10kohm resistor on the host board. Pull up voltage is between 2.0V and VccT+0.3V. When high, output indicates a laser fault of some kind. Low indicates normal operation. TxFault is asserted when bias current of laser exceeds the factory-calibrated threshold level or when output power of transmitter degrades above/below the factory-calibrated threshold level.

**TxDisable** TxDisable is an input that is used to shut down the transmitter optical output. It is pulled up within the module with a 4.7kohm resistor.

**MOD-DEF** MOD-DEF 0, 1 and 2 are module definition pins. They should be pulled up with a 4.7k to 10kohm resistor on the host board. The pull-up voltage shall be VccT. MOD-DEF0 indicates that the module is present. MOD-DEF1 is the clock line of two wire serial interface for serial ID. MOD-DEF2 is the data line of two wire serial interface for serial ID.

**LOS** LOS is an open collector output that shall be pulled up with a 4.7k to 10kohm resistor. Pull up voltage between 2.0V and VccR+0.3V. Low indicates normal operation.

**RD** RD+/- are the differential receiver outputs. They are AC-coupled 100ohm differential lines that should be terminated with 100ohm (differential) at the user's SERDES. The AC coupling is done inside the module and is thus not required on the host board.

**TD** TD+/- are the differential transmitter inputs. They are AC-coupled, differential lines with 100ohm differential termination inside the module. The AC coupling is done inside the module and is thus not required on the host board.

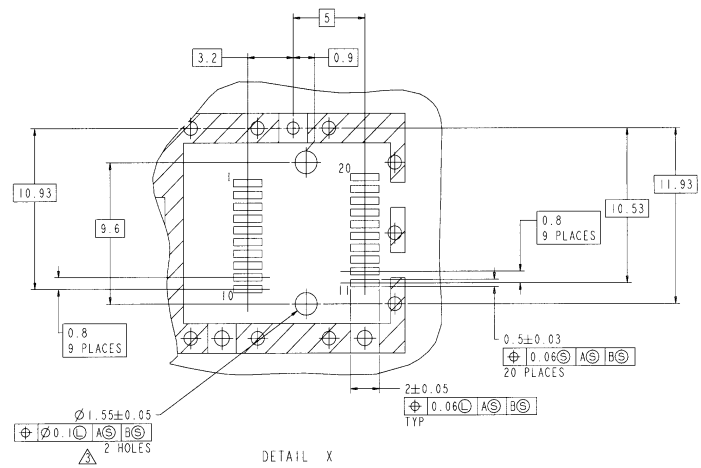

- Notes:
1. Datum and basic dimensions established by customer
  2. Pads and vias are chassis ground, 11 places
  3. Thru holes, plating optional

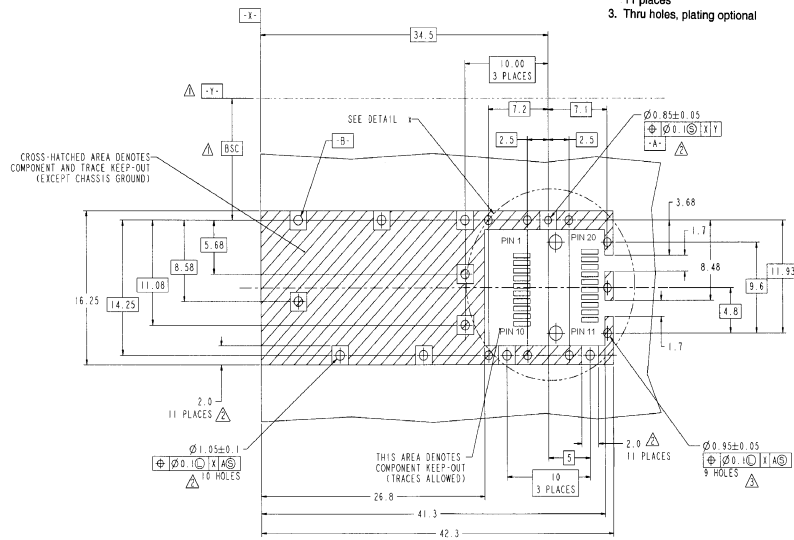
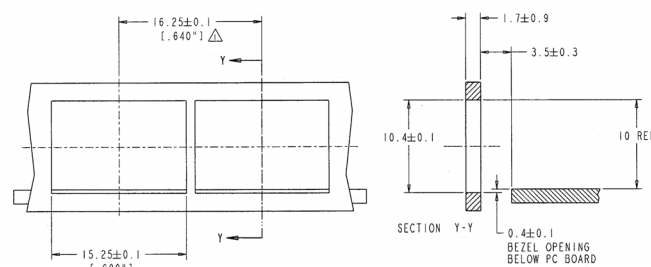

Figure 4 SFP host board mechanical layout



- NOTES:
1. MINIMUM PITCH ILLUSTRATED, ENGLISH DIMENSIONS ARE FOR REFERENCE ONLY
  2. NOT RECOMMENDED FOR PCI EXPANSION CARD APPLICATIONS

Figure 5 Recommended bezel design

## 5 Absolute maximum ratings

Parameter	Symbol	Min.	Typ.	Max.	Unit	Note
Storage ambient temperature	Ts	-40		85	deg.C	1
Operating case temperature	Tc	-40		85	deg.C	
Optical input level	Pin			3.0	dBm	
Supply voltage	VccT, R	0		4.0	V	
Input voltage	Vi	0		VccT+0.3	V	2
Sink current	Isink	-1		5	mA	3
Differential Input Voltage Swing (TD+,TD-)	Vin			2.5	Vp-p	

### Note

1. No condensation allowed.
2. For MOD-DEF (1:2) and Tx Disable.
3. For LOS and TxFault.

### Warning

 Use the product with the rated voltage described in the specification. If the voltage exceeds the maximum rating, overheating or fire may occur.

### Caution

 Do not store the product in the area where temperature exceeds the maximum rating, where there is too much moisture or dampness, where there is acid gas or corrosive gas, or other extreme conditions. Otherwise, failure, overheating or fire may occur.

## 6 Electrical interface

Unless otherwise specified, VccT, R=3.135 to 3.465V and all operating temperature shall be applied.

### 6.1 Operating characteristics

Parameter	Symbol	Min.	Typ.	Max.	Unit	Note
Supply Voltage	VccT, R	3.135	3.30	3.465	V	
Power Dissipation	Pw			1.0	W	1

### Note

1. 2488.32Mbps, PRBS 2<sup>23</sup>-1, NRZ, 50% duty cycle data.

### 6.2 Transmitter

Parameter	Symbol	Min.	Typ.	Max.	Unit	Note
Differential Input Voltage Swing (TD+,TD-)	Vin	0.3		1.6	Vpp	1
Input Differential Impedance	Zin	80	100	120	ohm	
Tx Fault	High	VfaultH	2.0	VccT+0.3	V	2
	Low	VfaultL	0	0.8	V	2, 3
Tx Disable	Disable	Vdi	2.0	VccT	V	4
	Enable	Vei	0	0.8	V	

### Note

1. Refer to Figure 6.
2. Tx Fault is pulled up to VccT with a 4.7k - 10kohm resistor on the host board.  
When high, output indicates a laser fault of some kind. Low indicates normal operation.
3. Sink Current: 3mA
4. Tx Disable input is internally terminated to VccT via 7.5kohm resistor. If left open, transmitter is disabled.

### 6.3 Receiver

Parameter		Symbol	Min.	Typ.	Max.	Unit	Note
Differential output voltage swing(RD+,RD-)		Vout	0.4		1.2	Vp-p	1
Data Rise / Fall Time		tr / tf			200	ps	2
LOS Output Voltage	High	Vloh	2.0		VccR+0.3	V	3
	Low	Vlol	0		0.8	V	3,4

**Note**

1. Rdiff=100ohm. Refer to figure 6.
2. 20-80% value.
3. LOS should be pulled up to VccR with a 4.7k – 10kohm resistor on the host board. Low indicates normal status.
4. Sink current 3mA.

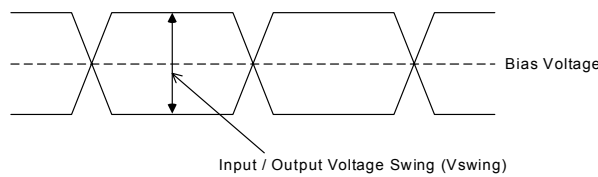

**Figure 6.** Definition of differential input/output voltage swing

### 6.4 Module definition

Parameter		Symbol	Min.	Typ.	Max.	Unit	Note
MOD_DEF(1:2) Input Voltage	High	Vih	2.0		VccT	V	1
	Low	Vil	0		0.8	V	
MOD_DEF(2) Output Voltage	High	Voh	2.0		VccT	V	1
	Low	Vol	0		0.8	V	1

**Note**

1. Should be pulled up to VccT with a 4.7k – 10kohm resistor on the host board.

## 7 Optical interface

Unless otherwise specified, VccT, R=3.135 to 3.465V and all operating temperature shall be applied.

### 7.1 Transmitter

Parameter	Symbol		SCP6G28	SCP6G08	Unit	Note
Bit Rate Range	-		2488.32Mbps +/- 100ppm		Mbps	
Average Output Power (Enabel)	Po	Max.	-3	0	dBm	1
		Min.	-10	-5		
Average Output Power (Disable)	Pdis	Max.	-45			
Extinction Ratio	Er	Min.	8.2		dB	
Center Wavelength	λc	Max.	1360	1360	nm	
		Min.	1266	1260		
Spectral Width (RMS)	Δλ,rms	Max.	4			
Spectral Width (-20dB Width)	Δλ-20	Max.		1		
Side Mode Suppression Ratio	SMSR	Min.		30	dB	
Eye Mask for Optical Output	Compliant with Telcordia GR-253 CORE and ITU-T G.957					
Jitter Generation	Tjpk	Max.	0.07		Ujpp	2
	Tjrms	Max.	0.007		Ujrms	

**Note**

1. Measured at 2488.32Mbps, PRBS2^23-1, 50%duty cycle, NRZ.

2. SONET OC-48c data pattern filled with a 2<sup>23</sup>-1, PRBS payload.

Measured with a band pass filter having a high-pass cutoff frequency of 12kHz and a low-pass cutoff frequency of 20MHz.

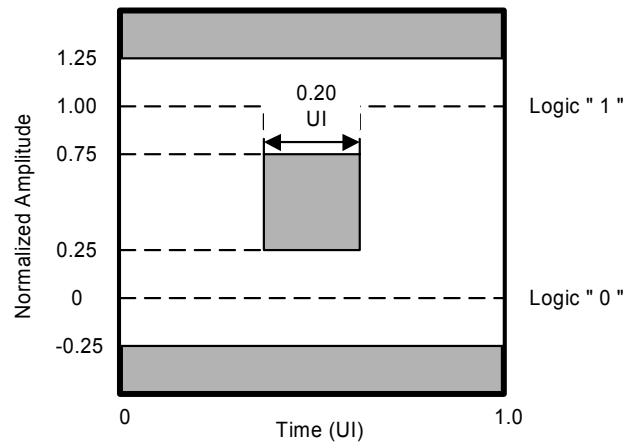

Figure 7. Optical Pulse Mask with Fourth Order Bessel Thomson Filter Specified in ITU-T G.957

<b>⚠ Warning</b>
<p>⊘ Do not look at the laser beam projection area (e.g. end of optical connector) with naked eyes or through optical equipment while the power is supplied to this product. Otherwise, your eyes may be injured.</p>

## 7.2 Receiver

Parameter	Symbol		SCP6G28	SCP6G08	Unit	Note	
Bit Rate Range	-		2488.32Mbps +/- 100ppm		Mbps		
Center Wavelength	-	Max.	1580		nm		
		Min.	1260				
Overload	Pmax	Min.	+0		dBm	1, 2	
Minimum Sensitivity	Pmin	Max.	-19				
LOS Activation Level	PLa	Max.	-19.5			dBm	2
		Min.	-35				
LOS Deactivation Level	PLd	Max.	-19				
		Min.	-34.5				
LOS Hysteresis	Phys	Max.	6.0		dB		
		Min.	0.5				
Optical Reflectance	REFr	Max	-27				

**Note**

1. BER = 1E-10.
2. Measured at 2488.32Mbps, PRBS2<sup>23</sup>-1, NRZ

## 7.3 Transceiver timing characteristics

Parameter	Symbol	Min.	Typ.	Max.	Unit	Note
TxDisable assert time	t_off			10	us	1
TxDisable negate time	t_on			1	ms	2
Time to initialize	t_init			300	ms	3
TxFault assert time	t_fault			100	us	4
TxDisable to reset	t_reset	10			us	5
LOS assert time	t_loss_on			100	us	6
LOS de-assert time	t_loss_off			100	us	7
Serial ID clock rate	-			100	kHz	

**Note**

1. Time from rising edge of TxDisable to when the optical output falls below 10% of nominal.
2. Time from falling edge of TxDisable to when the modulated optical output rises above 90% of nominal.

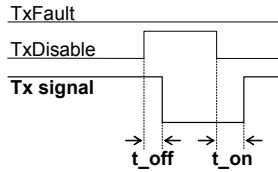

3. From power on or negation of TxFault using TxDisable.

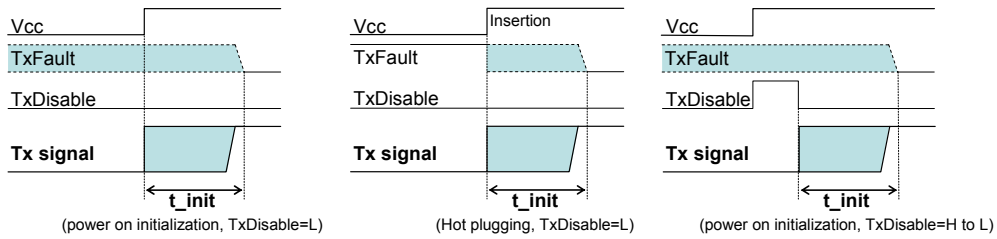

4. Time from transmitter's fault condition to TxFault on.
5. Time to reset TxFault status.

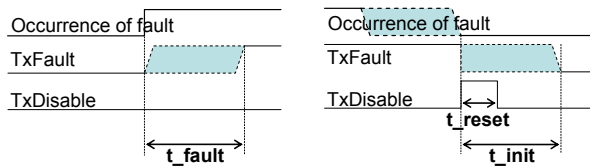

6. Time from Loss of signal state to LOS assert.
7. Time from non-LOS state to LOS de-assert.

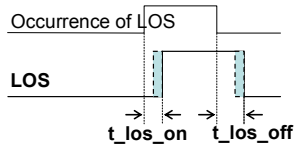

**Figure 8.** Transceiver timing charts

**7.4 TxFault and Tx shutdown options**

Type	TxFault	Tx shutdown on fault
A	Latched	No
B	Not latched	No
C	Latched	Yes

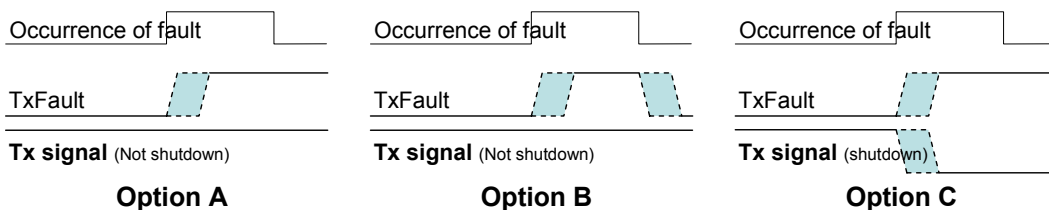

**Figure 9.** Part number identification for TxFault and Tx shutdown behavior

## 8 EEPROM memory contents

The data can be read using the 2-wire serial CMOS EEPROM protocol of the Atmel AT24C01A or equivalent.

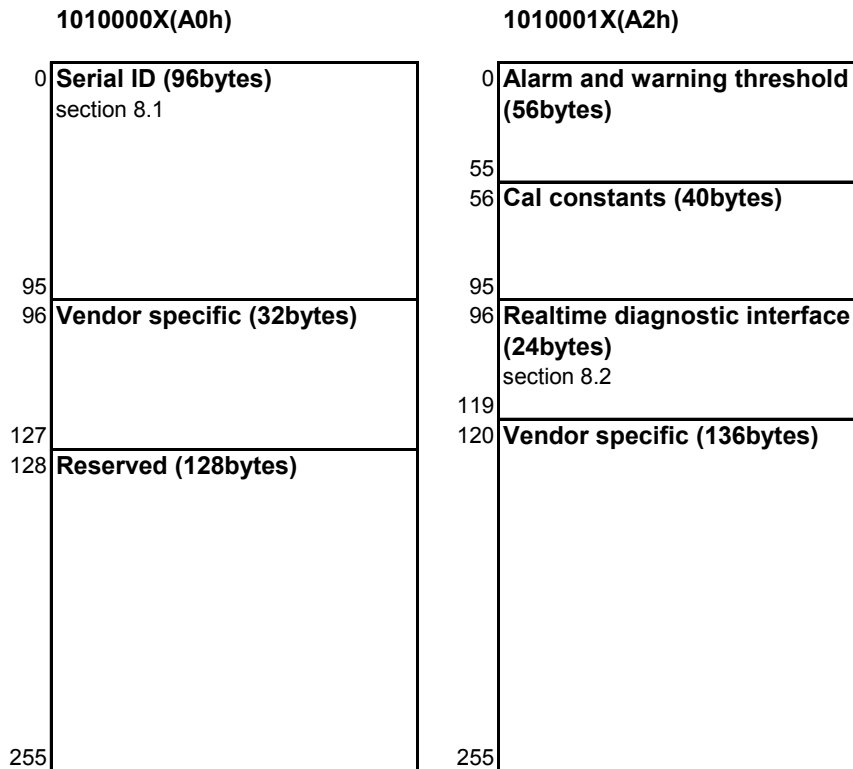

Figure 10. Digital diagnostic memory map

### 8.1. Serial ID (A0h)

Address	Name of field	Hex	ASCII	Description	Address	Name of field	Hex	ASCII	Description		
<b>BASE ID FIELDS</b>					<b>EXTENDED ID FIELDS</b>						
0	Identifier	03		SFP Transceiver	64	Options	00				
1	Ext. Identifier	04			65		1A				
2	Connector	07		LC Connector	66	BR, max	00				
3		00			67	BR, min	00				
4		00			68	Vendor SN	Note3		Year		
5		00			69			Month			
6		00			70						
7		00			71						
8		00			72						
9		00			73						
10		00			74						
11		Encoding	05		SONET Scrambled			75			
12	BR, Nominal	19		2488.32Mbps	76						
13	Reserved	00			77						
14	Length(9um) - km	Note1			78						
15	Length (9um)				79						
16	Length (50um)	00			80						
17	Length (62.5um)	00			81						
18	Length (Copper)	00			82						
19	Reserved	00			83						
20	Vendor name	53	S		84	Date code	Note4				
21		75	u		85						
22		6D	m		86						
23		69	i		87						
24		74	t		88						
25		6F	o		89						
26		6D	m		90						
27		6F	o		91						
28		45	E		92			Diagnostic Monitoring Type	58		Note6
29		6C	l		93			Enhanced Options	F0		Note7
30		65	e		94	SFF-8472 Compliance	01		Diagnostics		
31		63	c		95	CC_EXT	Note5				
32		74	t		<b>VENDOR SPECIFIC ID FIELDS</b>						
33		72	r		96	Read-only	20				
34	69	i		97	20						
35	63	c		98	20						
36	Reserved	00		99	20						
37	Vendor OUI	00		100	20						
38	5F			101	20						
39	53	S		102	20						
40	43	C		103	20						
41	50	P		104	20						
42	36	6		105	20						
43	47	G		106	20						
44	32/30	2/0		107	20						
45	38	8		108	20						
46	2D	-		109	20						
47	47	G		110	20						
48	4C	L		111	20						
49	2D	-		112	20						
50	41/42/43	A/B/C	TxFault Type	113	20						
51	57	W	Temperature Range	114	20						
52	45	E	Diagnostics	115	20						
53	20			116	20						
54	20			117	20						
55	20			118	20						
56	41 to 5A	A to Z	Variable	119	20						
57	20			120	20						
58	20			121	20						
59	20			122	20						
60	Wavelength	Note1		123	20						
61	Reserved	00		124	20						
62	Reserved	00		125	20						
63	CC_BASE	Note2		126	20						
				127	20						

**Note**

1. Refer to the section 8-2.
2. Address 63 is a checksum of bytes 0 to 62.
3. Address 68 to 83 is vendor's serial number area.
4. Address 84 to 91 is date-code.
5. Address 95 is a checksum of bytes 64 to 94.
6. Diagnostic monitoring types are listed below.

Address	Bit	Status	Description
92	7	0	Reserved for legacy diagnostic implementations.
92	6	1	Digital diagnostic monitoring is implemented.
92	5	0	externally calibrated
92	4	1	
92	3	1	Receiver power measurement type. 1=Average power.
92	2	0	Address change is not required.
92	1	0	Reserved
92	0	0	Reserved

7. Enhanced options are listed below.

Address	Bit	Status	Description
93	7	1	Alarm/warning flags implemented for all monitored quantities
93	6	1	Soft TxDisable control is implemented.
93	5	1	Soft TxFault monitoring is implemented.
93	4	1	Soft RxLOS monitoring is implemented.
93	3	0	Soft rate-select control and monitoring is not implemented.
93	2	0	Reserved
93	1	0	Reserved
93	0	0	Reserved

**8.2. SCP6G28/6G08-xWE EEPROM Information (Transceiver Code etc)**

Address	Name of field	SCP6G28	SCP6G08	Description
		Hex	Hex	
3	Transceiver	00	00	
4		01	12	01:SR, 12:IR-1, 0A:IR-2
5		00	00	
6		00	00	
7		00	00	
8		00	00	
9		00	00	
10		00	00	
14	Length(9um)- km	02	0F	02:2km, 0F:15km, 0F:15km
15	Length(9um)	14	96	14:20*100m, 96:150*100m, 96:150*100m
60	Wavelength	05	05	051E: 1310nm, 060E: 1550nm
61		1E	1E	

### 8.3 Real-time diagnostics (A2h)

Setting of bit 6, address 92 means digital diagnostic monitoring is implemented. Two calibration options are possible. If bit 5 of address 92, "Internally calibrated", is set, the transceiver directly reports calibrated values in units of current, power etc. If bit 4, "Externally calibrated", is set, the reported values are A/D counts which must be converted to real world units using calibration values read using 2 wire serial address 1010001X(A2h) from bytes 55 to 95. Monitoring range and accuracy are described in section 8.4.

Address	Bit	Name	Description
96	MSB	Temperature (T <sub>AD</sub> )	Junction temperature of the point illustrated in section 3. 16-bit signed 2's complement value. See Note 1 and 6.
97	LSB		
98	MSB	V <sub>CC</sub> (V <sub>AD</sub> )	Internally measured supply voltage "V <sub>CC</sub> T" in a module. Unsigned 16-bit value. See Note 2 and 6.
99	LSB		
100	MSB	Tx bias current (I <sub>AD</sub> )	Unsigned 16-bit value. See Note 3 and 6.
101	LSB		
102	MSB	Tx power (TP <sub>AD</sub> )	Measured TX output power. Unsigned 16-bit value. See Note 4 and 6.
103	LSB		
104	MSB	Rx power (RP <sub>AD</sub> )	Measured RX received power. Unsigned 16-bit value. 1digit=0.1uW. See Note 5 and 6.
105	LSB		
106	-	-	Reserved
107	-	-	Reserved
108	-	-	Reserved
109	-	-	Reserved

#### Note

- Temperature (1/256deg.C/digit)  $T = T_{slope} * T_{AD} + T_{offset}$  (Ext. cal.)
- V<sub>CC</sub> (100uV/digit)  $V = V_{slope} * V_{AD} + V_{offset}$  (Ext. cal.)
- TX bias current (2uA/digit)  $I = I_{slope} * I_{AD} + I_{offset}$  (Ext. cal.)
- TX power (0.1uW/digit)  $TP = TP_{slope} * TP_{AD} + TP_{offset}$  (Ext. cal.)
- RX power (0.1uW/digit)  $RP = RP4 * RP_{AD}^4 + RP3 * RP_{AD}^3 + RP2 * RP_{AD}^2 + RP1 * RP_{AD} + RP0$  (Ext. cal.)

6. Calibration constants(A2h) are listed below.

Address	Bytes	Name	Description
56:59	4	RP4	Single precision floating-point calibration data. Byte 56 is MSB.
60:63	4	PR3	Single precision floating-point calibration data. Byte 60 is MSB.
64:67	4	PR2	Single precision floating-point calibration data. Byte 64 is MSB.
68:71	4	PR1	Single precision floating-point calibration data. Byte 68 is MSB.
72:75	4	RP0	Single precision floating-point calibration data. Byte 72 is MSB.
76:77	2	I <sub>slope</sub>	Unsigned fixed-point calibration data. Byte 76 is MSB.
78:79	2	I <sub>offset</sub>	16-bit signed 2's complement calibration data. Byte 78 is MSB.
80:81	2	TP <sub>slope</sub>	Unsigned fixed-point calibration data. Byte 80 is MSB.
82:83	2	TP <sub>offset</sub>	16-bit signed 2's complement calibration data. Byte 82 is MSB.
84:85	2	T <sub>slope</sub>	Unsigned fixed-point calibration data. Byte 84 is MSB.
86:87	2	T <sub>offset</sub>	16-bit signed 2's complement calibration data. Byte 86 is MSB.
88:89	2	V <sub>slope</sub>	Unsigned fixed-point calibration data. Byte 88 is MSB.
90:91	2	V <sub>offset</sub>	16-bit signed 2's complement calibration data. Byte 90 is MSB.
92:94	3	-	Reserved
95	1	-	Checksum. Low order 8 bits of the sum at data address 0 to 94.

#### 8.4 A/D accuracy and monitoring range

Parameter	Accuracy	Monitoring range		Unit	Note
		Min.	Max.		
Temperature	+/- 3deg.C	-40	85	deg.C	1
Vcc	+/- 3%	3.135	3.465	V	
Tx bias current	+/- 10%	1	60	mA	2
Tx power	+/- 3dB	-10	-3	dBm	SCP6G28
		-5	+0		SCP6G08
Rx Power Note3	+/-3dB	-22	+0	dBm	

**Note**

1. Junction temperature. Specified at Vcc=3.3V.
2. Specified by nominal value.
3. At specified transmitter wavelength.

#### 8.5 Optional status bit(A2h)

Address	Bit	Name	Description
110	0	Data ready bar	Indicates transceiver has achieved power up and data is ready. Bit remains high until data is ready to be read.

#### 8.6 Alarm and Warning Flags(A2h)

Address	Bit	Name	Description
112	7	Temp High Alarm	Set when temperature exceeds high alarm level.
	6	Temp Low Alarm	Set when temperature is below low alarm level.
	5	Vcc High Alarm	Set when measured internal voltage exceeds high alarm level.
	4	Vcc Low Alarm	Set when measured internal voltage is below low alarm level.
	3	Tx bias High Alarm	Set when TX bias current exceeds high alarm level.
	2	Tx bias Low Alarm	Set when TX bias current is below low alarm level.
	1	Tx power High Alarm	Set when TX output power exceeds high alarm level.
	0	Tx power Low Alarm	Set when TX output power is below low alarm level.
113	7	RX power High Alarm	Set when received power exceeds high alarm level.
	6	RX power Low Alarm	Set when received power is below low alarm level.
	5:0	Reserved	
114	7:0	Reserved	
115	7:0	Reserved	
116	7	Temp High Warning	Set when temperature exceeds high warning level.
	6	Temp Low Warning	Set when temperature is below low warning level.
	5	Vcc High Warning	Set when measured internal voltage exceeds high warning level.
	4	Vcc Low Warning	Set when measured internal voltage is below low warning level.
	3	Tx bias High Warning	Set when TX bias current exceeds high warning level.
	2	Tx bias Low Warning	Set when TX bias current is below low warning level.
	1	Tx power High Warning	Set when TX output power exceeds high warning level.
	0	Tx power Low Warning	Set when TX output power is below low warning level.
117	7	RX power High Warning	Set when received power exceeds high warning level.
	6	RX power Low Warning	Set when received power is below low warning level.
	5:0	Reserved	
118	7:0	Reserved	
119	7:0	Reserved	

## 8.5 Alarm and Warning warning threshold

A2h Address	Meaning	Unit	SCP6G08-GL-AWE	SCP6G28-GL-AWE
00-01	Temp High Alarm	deg	97	105
02-03	Temp Low Alarm	deg	-45	-45
04-05	Temp High Warning	deg	95	95
06-07	Temp Low Warning	deg	-45	-45
08-09	Vcc High Alarm	V	4	4
10-11	Vcc Low Alarm	V	2.8	2.8
12-13	Vcc High Warning	V	3.6	3.6
14-15	Vcc Low Warning	V	3	3
16-17	TX Bias High Alarm	mA	70	70
18-19	TX Bias Low Alarm	mA	0	0
20-21	TX Bias High Warning	mA	60	60
22-23	TX Bias Low Warning	mA	0	0
24-25	TX Power High Alarm	dBm	+3	0
26-27	TX Power Low Alarm	dBm	-8	-13
28-29	TX Power High Warning	dBm	+1	-2
30-31	TX Power Low Warning	dBm	-6	-11
32-33	RX Power High Alarm	dBm	NA	NA
34-35	RX Power Low Alarm	dBm	NA	NA
36-37	RX Power High Warning	dBm	NA	NA
38-39	RX Power Low Warning	dBm	NA	NA

## 9 Recommended interface circuit

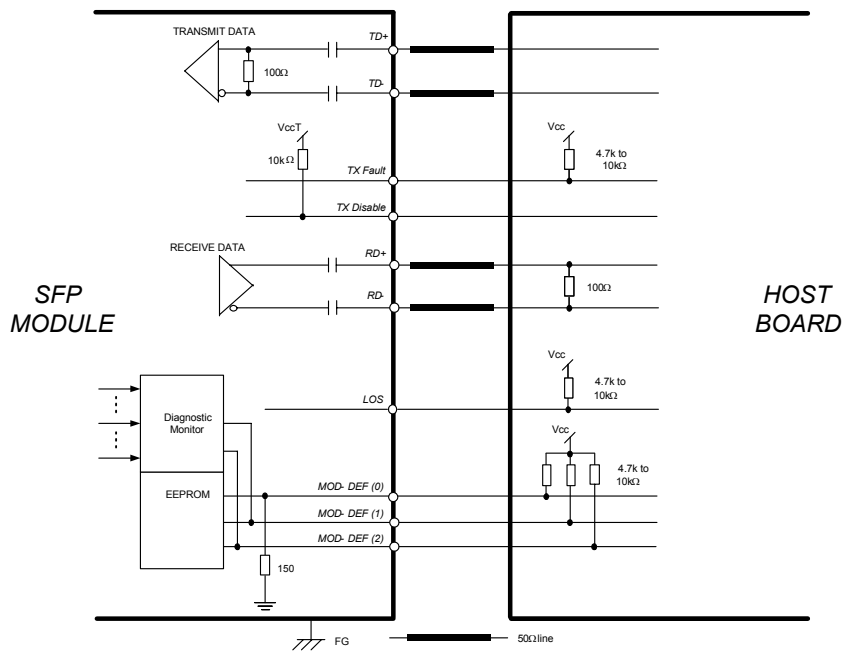

Figure 11. Recommended interface circuit

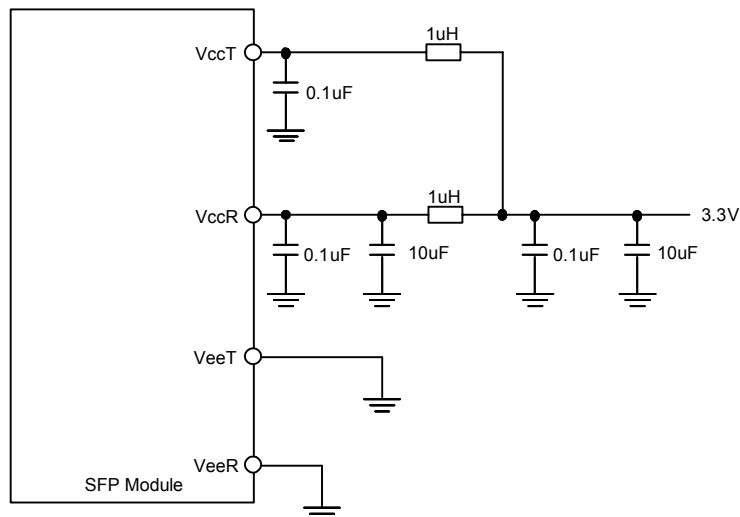

Figure 12. Recommended supply filtering network

## 10. RoHS COMPLIANCY

Compliance versus requirements contained inside the following reference document is guaranteed:  
"Directive 2002/95/EC of 27 January 2003 on the restriction of the use of certain hazardous substances in electrical and electronic equipment: from official journal of European Union (European Parliament and of the Council). This product is Compliant at RoHS-6/6 level and Contains no leaded solders.

## 11 Reliability test program

GR-468-CORE Issue 1, December 1998 Laser module

Heading	Test	Reference	Conditions	Sampling		
				LTPD	SS	C
Mechanical Integrity	Mechanical shock	MIL-STD-883 Method 2002	5 times/axis 1,500G, 0.5ms	20	11	0
	Vibration	MIL-STD-883 Method 2007	Cond. A 20G, 20 to 2,000Hz, 4min/cy, 4cy/axis	20	11	0
Endurance	Accel. aging (High temp.)	(R)-4-53 Section 5.18	85deg.C; rated power 1,000h for pass/fail 2,000 & 5,000h for info	-	25 10	-
	Low temp. storage	-	Minimum storage temperature 1,000h for pass/fail 2,000h for info	20	11	0
	Temperature cycling	Section 5.20	-40 to 85deg.C 500cy for pass/fail 1,000cy for info	20 -	11 11	0 -
	Damp heat with bias	MIL-STD-202 Method 103 or IEC-60068-2-3	85deg.C/85%RH 1,000h	20	11	0
	Cyclic moisture resistance	Section 5.23	-	20	11	0
Special test	Internal moisture	MIL-STD-883 Method 1018	Max. 5,000ppm water vapor	20	11	0
	ESD threshold	Section 5.22		-	6	-

SS; sample size

C; maximum number of failure allowed to pass the test.

## 12 Laser safety



This product uses a semiconductor laser system and is a laser class 1 product acceptable FDA, complies with 21CFR 1040.10 and 1040.11. Also this product is a laser class 1 product acceptable IEC60825-1:2001.

 <b>Caution</b>	
	If this product is used under conditions not recommended in the specification or this product is used with unauthorized revision, classification for laser product safety standard is invalid. Classify the product again at your responsibility and take appropriate actions.

## 13 Other precaution

Under such a strong vibration environment as in automobile, the performance and reliability are not guaranteed. The governmental approval is required to export this product to other countries. To dispose of these components, the appropriate procedure should be taken to prevent illegal exportation.

This module must be handled, used and disposed of according to your company's safe working practice.

 <b>Warning</b>	
	Operating transceiver products can have an outer package temperature exceeding 70 degC. To reduce the risk of injury from burns, do not touch the transceiver module under any circumstances while it is operational. When installing or uninstalling products that have been operating, handle with extreme care.

<b>⚠ Warning</b>	
	Do not put this product or components of this product into your mouth. This product contains material harmful to health.

<b>⚠ Caution</b>	
	Dispose this product or equipment including this product properly as industrial waste according to the regulations.

## 14 Ordering information

Part number

**SCP6G**  **8** - **GL** -  **W** **E**

Calibration type of diagnostic monitor

E: External calibration

Operating case temperature range

W: -40 to 85degC

TxFault type

Type	TxFault	Tx shutdown on fault
A	Latched	No
B	Not latched	No
C	Latched	Yes

Transmitter Distance and Wavelength

2: SR (2Km), 1310nm

0: IR-1 (15Km), 1310nm

## 15 For more information

### U.S.A.

#### Excelight Communications, Inc.

4021 Stirrup Creek Drive, Suite 200, Durham, NC 27703 USA

Tel. +1-919-361-1600 / Fax. +1-919-361-1619

E-mail: [info@excelight.com](mailto:info@excelight.com)

<http://www.excelight.com>

### Europe

#### Sumitomo Electric Europe Ltd.

220 Centennial Park, Elstree, Herts, WD6 3SL UK

Tel. +44-208-953-8681 / Fax. +44-208-207-5950

E-mail: [photonics@sumielectric.com](mailto:photonics@sumielectric.com)

<http://www.sumielectric.com>

### Japan

#### Sumitomo Electric Industries, Ltd.

1 Taya-cho, Sakae-ku, Yokohama, 244-8588 Japan

Tel. +81-45-853-7154 / Fax. +81-45-851-1932

E-mail: [product-info@ppd.sei.co.jp](mailto:product-info@ppd.sei.co.jp)

[http://www.sei.co.jp/Electro-optic/index\\_e.html](http://www.sei.co.jp/Electro-optic/index_e.html)