

Mellanox Cable Modules

Mellanox active optical and RJ45 cable modules provide outstanding performance for high-bandwidth fabrics, extending the benefits of Mellanox’s high-performance InfiniBand and Ethernet adapters and switches throughout the network.

In addition to meeting or exceeding InfiniBand Trade Association (IBTA) and IEEE standards, Mellanox certified modules are 100% tested on Mellanox equipment to ensure optimal signal integrity and the best end-to-end performance.

Mellanox QSFP SR4 module uses MTP/MPO connector type to connect an OM3/OM4 fiber cable.

Mellanox QSFP LR4 module uses LC-LC connector type to connect a fiber cable.

Mellanox SFP/ SFP+ optical modules use LC-LC connector type to connect a single mode or multimode fiber cable.

Mellanox Base-T modules use RJ45 connector type to connect RJ45 cable.

Mellanox optical solutions provide short, medium and long range scalability for all topologies, utilizing innovative optical technologies to enable extremely high signal integrity and reliability. Rigorous production testing ensures best out-of-the-box installation experience, performance and durability.

HIGHLIGHTS

- Low power consumption
- Compliant with SFF-8436
- Compliant with SFF-8431
- Compliant with SFF-8432
- Low insertion loss
- BER Better than 10⁻¹⁵
- Tested in Mellanox’s end-to-end environment
- RoHS 6 compliant

Table 1 - Modules Specifications and Ordering Information

Form Factor	Application	Connector	Cable Length (up to)	Wavelength	Supply Voltage [V]		Max Power Consumption [W]	Part Number
					Min	Max		
QSFP	Ethernet 40GbE	MPO	100m	850nm	3.15	3.63	1.5	MC2210411-SR4
QSFP	Ethernet 40GbE / InfiniBand FDR10,QDR	LC-LC	10km	1310nm	3.1	3.5	3.5	MC2210511-LR4
QSFP	InfiniBand QDR	MPO	100m	850nm	3.15	3.45	1.7	MFM4R12C-QDR
SFP+	Ethernet 10GbE	LC-LC	300m	850nm	3.15	3.8	1	MFM1T02A-SR
SFP+	Ethernet 10GbE	LC-LC	10km	1310nm	3.15	3.8	1	MFM1T02A-LR MC3309411-SR
SFP	Ethernet 1GbE	LC-LC	500m	850nm	3.15	4	1	MC3208011-SX
SFP	Ethernet 1GbE	RJ-45 Base T	100m	-	3.13	3.47	1	MC3208411-T

Table 2 - Absolute Maximum Ratings

Parameter	Min	Max	Units
Operating Case Temperature	0	70	°C
Storage Ambient Temperature	0	75	°C

QSFP

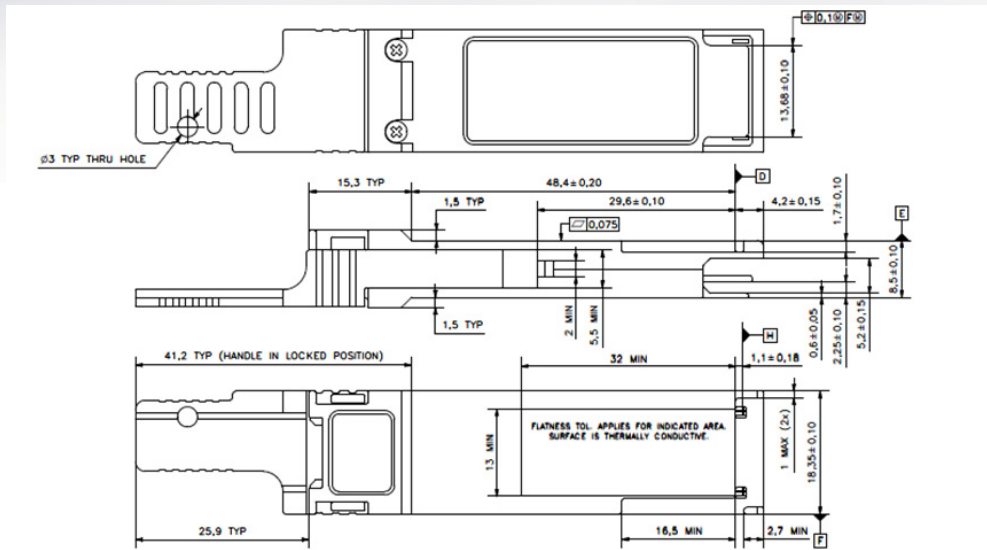

SFP/SFP+

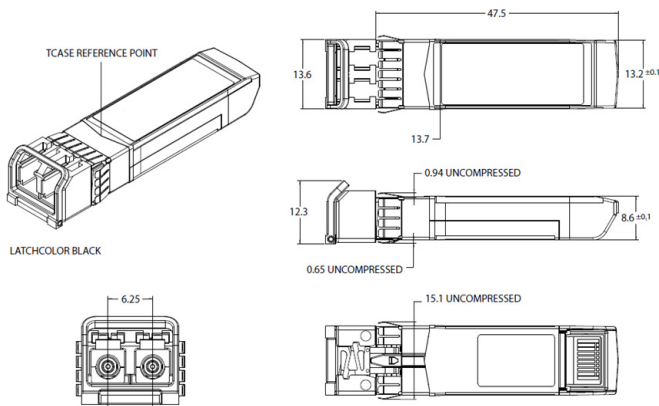

SFP Base T

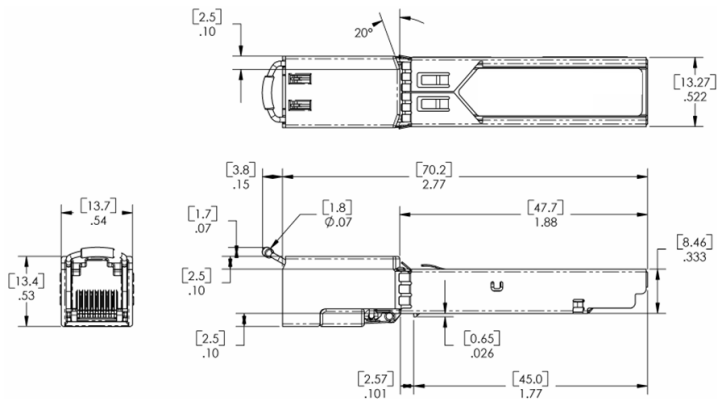

350 Oakmead Parkway, Suite 100, Sunnyvale, CA 94085
 Tel: 408-970-3400 • Fax: 408-970-3403
www.mellanox.com