



**Hewlett Packard**  
Enterprise

# **HPE ProLiant XL230a Gen9 Server**

## Maintenance and Service Guide

### Abstract

This guide is for an experienced service technician. Hewlett Packard Enterprise assumes you are qualified in the servicing of computer equipment and trained in recognizing hazards in products with hazardous energy levels and are familiar with weight and stability precautions for rack installations.

Part Number: 752035-006a  
April 2016  
Edition: 7

© Copyright 2014, 2016 Hewlett Packard Enterprise Development LP

The information contained herein is subject to change without notice. The only warranties for Hewlett Packard Enterprise products and services are set forth in the express warranty statements accompanying such products and services. Nothing herein should be construed as constituting an additional warranty. Hewlett Packard Enterprise shall not be liable for technical or editorial errors or omissions contained herein.

Links to third-party websites take you outside the Hewlett Packard Enterprise website. Hewlett Packard Enterprise has no control over and is not responsible for information outside Hewlett Packard Enterprise website.

Microsoft® and Windows® are trademarks of the Microsoft group of companies.

Intel® Xeon® is a trademark of Intel Corporation in the U.S. and other countries.

MicroSD is a trademark or registered trademark of SD-3C in the United States, other countries or both.

# Contents

Customer self repair.....	5
Parts only warranty service .....	5
Illustrated parts catalog.....	15
Server system components.....	15
I/O module components .....	22
Removal and replacement procedures .....	25
Required tools .....	25
Safety considerations .....	25
Preventing electrostatic discharge.....	25
Symbols on equipment.....	25
System warnings and cautions.....	26
Preparation procedures.....	26
Power down the server.....	26
Remove the server.....	27
Install the service tray.....	28
Remove the I/O module.....	28
Install the server.....	29
Removing and replacing a drive.....	30
PCIe/FlexibleLOM I/O module.....	31
PCIe/FlexibleLOM I/O module PCIe options.....	31
PCIe/FlexibleLOM I/O module FlexibleLOM options.....	32
Dual FlexibleLOM riser options .....	33
Processor air baffle .....	34
DIMMs .....	34
PCIe riser board assembly.....	35
PCIe expansion board options .....	36
Cache module .....	36
HPE Smart Storage Battery option.....	37
Hot-plug drive cage assembly.....	38
Front panel LED board assembly.....	40
System battery .....	41
Heatsink .....	42
Processor .....	44
System board .....	47
Re-entering the server serial number and product ID .....	49
HP Trusted Platform Module.....	50
Troubleshooting .....	51
Troubleshooting resources.....	51
Diagnostic tools .....	52
Product QuickSpecs.....	52
HPE iLO .....	52
Active Health System .....	52
HPE ProLiant Pre-boot Health Summary.....	53
Integrated Management Log .....	54
HPE UEFI System Utilities .....	54
Using UEFI System Utilities.....	54
Embedded Diagnostics option.....	55
Re-entering the server serial number and product ID .....	55
HPE Insight Diagnostics.....	55
HPE Insight Diagnostics survey functionality .....	55
HPE Insight Remote Support .....	56

USB support .....	56
External USB functionality .....	56
Automatic Server Recovery .....	56
Component identification .....	58
Front panel components .....	58
Front panel LEDs and buttons .....	59
Front panel LED power fault codes .....	59
System board components .....	60
DIMM slot locations .....	61
System maintenance switch .....	61
Drive numbering .....	62
Hot-plug drive numbering (single 12G drive backplane) .....	62
Hot-plug drive numbering (dual 6G drive backplanes) .....	63
Non-hot-plug drive numbering .....	64
Hot-plug drive LED definitions .....	64
I/O module bay numbering .....	65
I/O module slot definitions .....	66
Cabling .....	67
Internal server cabling .....	67
Drive cabling .....	67
HPE Smart Storage Battery cabling .....	70
Front panel LED board assembly cabling .....	71
SUV cable connectors .....	71
Specifications .....	72
Environmental specifications .....	72
Server specifications .....	72
Acronyms and abbreviations .....	73
Documentation feedback .....	75
Index .....	76

# Customer self repair

Hewlett Packard Enterprise products are designed with many Customer Self Repair (CSR) parts to minimize repair time and allow for greater flexibility in performing defective parts replacement. If during the diagnosis period Hewlett Packard Enterprise (or Hewlett Packard Enterprise service providers or service partners) identifies that the repair can be accomplished by the use of a CSR part, Hewlett Packard Enterprise will ship that part directly to you for replacement. There are two categories of CSR parts:

- **Mandatory**—Parts for which customer self repair is mandatory. If you request Hewlett Packard Enterprise to replace these parts, you will be charged for the travel and labor costs of this service.
- **Optional**—Parts for which customer self repair is optional. These parts are also designed for customer self repair. If, however, you require that Hewlett Packard Enterprise replace them for you, there may or may not be additional charges, depending on the type of warranty service designated for your product.

**NOTE:** Some Hewlett Packard Enterprise parts are not designed for customer self repair. In order to satisfy the customer warranty, Hewlett Packard Enterprise requires that an authorized service provider replace the part. These parts are identified as "No" in the Illustrated Parts Catalog.

Based on availability and where geography permits, CSR parts will be shipped for next business day delivery. Same day or four-hour delivery may be offered at an additional charge where geography permits. If assistance is required, you can call the Hewlett Packard Enterprise Support Center and a technician will help you over the telephone. Hewlett Packard Enterprise specifies in the materials shipped with a replacement CSR part whether a defective part must be returned to Hewlett Packard Enterprise. In cases where it is required to return the defective part to Hewlett Packard Enterprise, you must ship the defective part back to Hewlett Packard Enterprise within a defined period of time, normally five (5) business days. The defective part must be returned with the associated documentation in the provided shipping material. Failure to return the defective part may result in Hewlett Packard Enterprise billing you for the replacement. With a customer self repair, Hewlett Packard Enterprise will pay all shipping and part return costs and determine the courier/carrier to be used.

For more information about the Hewlett Packard Enterprise CSR program, contact your local service provider. For the North American program, go to the Hewlett Packard Enterprise CSR website (<http://www.hpe.com/support/selfrepair>).

## Parts only warranty service

Your Hewlett Packard Enterprise Limited Warranty may include a parts only warranty service. Under the terms of parts only warranty service, Hewlett Packard Enterprise will provide replacement parts free of charge.

For parts only warranty service, CSR part replacement is mandatory. If you request Hewlett Packard Enterprise to replace these parts, you will be charged for the travel and labor costs of this service.

## Réparation par le client (CSR)

Les produits Hewlett Packard Enterprise comportent de nombreuses pièces CSR (Customer Self Repair = réparation par le client) afin de minimiser les délais de réparation et faciliter le remplacement des pièces défectueuses. Si pendant la période de diagnostic, Hewlett Packard Enterprise (ou ses partenaires ou mainteneurs agréés) détermine que la réparation peut être effectuée à l'aide d'une pièce CSR, Hewlett Packard Enterprise vous l'envoie directement. Il existe deux catégories de pièces CSR :

- **Obligatoire**—Pièces pour lesquelles la réparation par le client est obligatoire. Si vous demandez à Hewlett Packard Enterprise de remplacer ces pièces, les coûts de déplacement et main d'œuvre du service vous seront facturés.
- **Facultatif**—Pièces pour lesquelles la réparation par le client est facultative. Ces pièces sont également conçues pour permettre au client d'effectuer lui-même la réparation. Toutefois, si vous demandez à Hewlett Packard Enterprise de remplacer ces pièces, l'intervention peut ou non vous être facturée, selon le type de garantie applicable à votre produit.

**REMARQUE:** Certaines pièces Hewlett Packard Enterprise ne sont pas conçues pour permettre au client d'effectuer lui-même la réparation. Pour que la garantie puisse s'appliquer, Hewlett Packard Enterprise exige que le remplacement de la pièce soit effectué par un Mainteneur Agréé. Ces pièces sont identifiées par la mention "Non" dans le Catalogue illustré.

Les pièces CSR sont livrées le jour ouvré suivant, dans la limite des stocks disponibles et selon votre situation géographique. Si votre situation géographique le permet et que vous demandez une livraison le jour même ou dans les 4 heures, celle-ci vous sera facturée. Pour toute assistance, appelez le Centre d'assistance Hewlett Packard Enterprise pour qu'un technicien vous aide au téléphone. Dans les documents envoyés avec la pièce de rechange CSR, Hewlett Packard Enterprise précise s'il est nécessaire de lui retourner la pièce défectueuse. Si c'est le cas, vous devez le faire dans le délai indiqué, généralement cinq (5) jours ouvrés. La pièce et sa documentation doivent être retournées dans l'emballage fourni. Si vous ne retournez pas la pièce défectueuse, Hewlett Packard Enterprise se réserve le droit de vous facturer les coûts de remplacement. Dans le cas d'une pièce CSR, Hewlett Packard Enterprise supporte l'ensemble des frais d'expédition et de retour, et détermine la société de courses ou le transporteur à utiliser.

Pour plus d'informations sur le programme CSR de Hewlett Packard Enterprise, contactez votre Mainteneur Agréé local. Pour plus d'informations sur ce programme en Amérique du Nord, consultez le site Web Hewlett Packard Enterprise (<http://www.hpe.com/support/selfrepair>).

## Service de garantie "pièces seules"

Votre garantie limitée Hewlett Packard Enterprise peut inclure un service de garantie "pièces seules". Dans ce cas, les pièces de rechange fournies par Hewlett Packard Enterprise ne sont pas facturées.

Dans le cadre de ce service, la réparation des pièces CSR par le client est obligatoire. Si vous demandez à Hewlett Packard Enterprise de remplacer ces pièces, les coûts de déplacement et main d'œuvre du service vous seront facturés.

## Riparazione da parte del cliente

Per abbreviare i tempi di riparazione e garantire una maggiore flessibilità nella sostituzione di parti difettose, i prodotti Hewlett Packard Enterprise sono realizzati con numerosi componenti che possono essere riparati direttamente dal cliente (CSR, Customer Self Repair). Se in fase di diagnostica Hewlett Packard Enterprise (o un centro di servizi o di assistenza Hewlett Packard Enterprise) identifica il guasto come riparabile mediante un ricambio CSR, Hewlett Packard Enterprise lo spedisce direttamente al cliente per la sostituzione. Vi sono due categorie di parti CSR:

- **Obbligatorie**—Parti che devono essere necessariamente riparate dal cliente. Se il cliente ne affida la riparazione ad Hewlett Packard Enterprise, deve sostenere le spese di spedizione e di manodopera per il servizio.
- **Opzionali**—Parti la cui riparazione da parte del cliente è facoltativa. Si tratta comunque di componenti progettati per questo scopo. Se tuttavia il cliente ne richiede la sostituzione ad Hewlett Packard Enterprise, potrebbe dover sostenere spese aggiuntive a seconda del tipo di garanzia previsto per il prodotto.

**NOTA:** alcuni componenti Hewlett Packard Enterprise non sono progettati per la riparazione da parte del cliente. Per rispettare la garanzia, Hewlett Packard Enterprise richiede che queste parti siano sostituite da un centro di assistenza autorizzato. Tali parti sono identificate da un "No" nel Catalogo illustrato dei componenti.

In base alla disponibilità e alla località geografica, le parti CSR vengono spedite con consegna entro il giorno lavorativo seguente. La consegna nel giorno stesso o entro quattro ore è offerta con un supplemento di costo solo in alcune zone. In caso di necessità si può richiedere l'assistenza telefonica di un addetto del centro di supporto tecnico Hewlett Packard Enterprise. Nel materiale fornito con una parte di ricambio CSR, Hewlett Packard Enterprise specifica se il cliente deve restituire dei componenti. Qualora sia richiesta la resa ad Hewlett Packard Enterprise del componente difettoso, lo si deve spedire ad Hewlett Packard Enterprise entro un determinato periodo di tempo, generalmente cinque (5) giorni lavorativi. Il componente difettoso deve essere restituito con la documentazione associata nell'imballo di spedizione fornito. La mancata restituzione del componente può comportare la fatturazione del ricambio da parte di Hewlett Packard Enterprise. Nel caso di riparazione da parte del cliente, Hewlett Packard Enterprise sostiene tutte le spese di spedizione e resa e sceglie il corriere/vettore da utilizzare.

Per ulteriori informazioni sul programma CSR di Hewlett Packard Enterprise, contattare il centro di assistenza di zona. Per il programma in Nord America fare riferimento al sito Web (<http://www.hpe.com/support/selfrepair>).

## Servizio di garanzia per i soli componenti

La garanzia limitata Hewlett Packard Enterprise può includere un servizio di garanzia per i soli componenti. Nei termini di garanzia del servizio per i soli componenti, Hewlett Packard Enterprise fornirà gratuitamente le parti di ricambio.

Per il servizio di garanzia per i soli componenti è obbligatoria la formula CSR che prevede la riparazione da parte del cliente. Se il cliente invece richiede la sostituzione ad Hewlett Packard Enterprise dovrà sostenere le spese di spedizione e di manodopera per il servizio.

## Customer Self Repair

Hewlett Packard Enterprise Produkte enthalten viele CSR-Teile (Customer Self Repair), um Reparaturzeiten zu minimieren und höhere Flexibilität beim Austausch defekter Bauteile zu ermöglichen. Wenn Hewlett Packard Enterprise (oder ein Hewlett Packard Enterprise Servicepartner) bei der Diagnose feststellt, dass das Produkt mithilfe eines CSR-Teils repariert werden kann, sendet Ihnen Hewlett Packard Enterprise dieses Bauteil zum Austausch direkt zu. CSR-Teile werden in zwei Kategorien unterteilt:

- **Zwingend**—Teile, für die das Customer Self Repair-Verfahren zwingend vorgegeben ist. Wenn Sie den Austausch dieser Teile von Hewlett Packard Enterprise vornehmen lassen, werden Ihnen die Anfahrt- und Arbeitskosten für diesen Service berechnet.
- **Optional**—Teile, für die das Customer Self Repair-Verfahren optional ist. Diese Teile sind auch für Customer Self Repair ausgelegt. Wenn Sie jedoch den Austausch dieser Teile von Hewlett Packard Enterprise vornehmen lassen möchten, können bei diesem Service je nach den für Ihr Produkt vorgesehenen Garantiebedingungen zusätzliche Kosten anfallen.

**HINWEIS:** Einige Hewlett Packard Enterprise Teile sind nicht für Customer Self Repair ausgelegt. Um den Garantieanspruch des Kunden zu erfüllen, muss das Teil von einem Hewlett Packard Enterprise Servicepartner ersetzt werden. Im illustrierten Teilekatalog sind diese Teile mit „No“ bzw. „Nein“ gekennzeichnet.

CSR-Teile werden abhängig von der Verfügbarkeit und vom Lieferziel am folgenden Geschäftstag geliefert. Für bestimmte Standorte ist eine Lieferung am selben Tag oder innerhalb von vier Stunden gegen einen Aufpreis verfügbar. Wenn Sie Hilfe benötigen, können Sie das Hewlett Packard Enterprise

Support Center anrufen und sich von einem Mitarbeiter per Telefon helfen lassen. Den Materialien von Hewlett Packard Enterprise, die mit einem CSR-Ersatzteil geliefert werden, können Sie entnehmen, ob das defekte Teil an Hewlett Packard Enterprise zurückgeschickt werden muss. Wenn es erforderlich ist, das defekte Teil an Hewlett Packard Enterprise zurückzuschicken, müssen Sie dies innerhalb eines vorgegebenen Zeitraums tun, in der Regel innerhalb von fünf (5) Geschäftstagen. Das defekte Teil muss mit der zugehörigen Dokumentation in der Verpackung zurückgeschickt werden, die im Lieferumfang enthalten ist. Wenn Sie das defekte Teil nicht zurückschicken, kann Hewlett Packard Enterprise Ihnen das Ersatzteil in Rechnung stellen. Im Falle von Customer Self Repair kommt Hewlett Packard Enterprise für alle Kosten für die Lieferung und Rücksendung auf und bestimmt den Kurier-/Frachtdienst.

Weitere Informationen über das Hewlett Packard Enterprise Customer Self Repair Programm erhalten Sie von Ihrem Servicepartner vor Ort. Informationen über das CSR-Programm in Nordamerika finden Sie auf der Hewlett Packard Enterprise Website unter (<http://www.hpe.com/support/selfrepair>).

## Parts-only Warranty Service (Garantieservice ausschließlich für Teile)

Ihre Hewlett Packard Enterprise Garantie umfasst möglicherweise einen Parts-only Warranty Service (Garantieservice ausschließlich für Teile). Gemäß den Bestimmungen des Parts-only Warranty Service stellt Hewlett Packard Enterprise Ersatzteile kostenlos zur Verfügung.

Für den Parts-only Warranty Service ist das CSR-Verfahren zwingend vorgegeben. Wenn Sie den Austausch dieser Teile von Hewlett Packard Enterprise vornehmen lassen, werden Ihnen die Anfahrt- und Arbeitskosten für diesen Service berechnet.

## Reparaciones del propio cliente

Los productos de Hewlett Packard Enterprise incluyen muchos componentes que el propio usuario puede reemplazar (Customer Self Repair, CSR) para minimizar el tiempo de reparación y ofrecer una mayor flexibilidad a la hora de realizar sustituciones de componentes defectuosos. Si, durante la fase de diagnóstico, Hewlett Packard Enterprise (o los proveedores o socios de servicio de Hewlett Packard Enterprise) identifica que una reparación puede llevarse a cabo mediante el uso de un componente CSR, Hewlett Packard Enterprise le enviará dicho componente directamente para que realice su sustitución. Los componentes CSR se clasifican en dos categorías:

- **Obligatorio**—Componentes cuya reparación por parte del usuario es obligatoria. Si solicita a Hewlett Packard Enterprise que realice la sustitución de estos componentes, tendrá que hacerse cargo de los gastos de desplazamiento y de mano de obra de dicho servicio.
- **Opcional**—Componentes cuya reparación por parte del usuario es opcional. Estos componentes también están diseñados para que puedan ser reparados por el usuario. Sin embargo, si precisa que Hewlett Packard Enterprise realice su sustitución, puede o no conllevar costes adicionales, dependiendo del tipo de servicio de garantía correspondiente al producto.

**NOTA:** Algunos componentes de Hewlett Packard Enterprise no están diseñados para que puedan ser reparados por el usuario. Para que el usuario haga valer su garantía, Hewlett Packard Enterprise pone como condición que un proveedor de servicios autorizado realice la sustitución de estos componentes. Dichos componentes se identifican con la palabra "No" en el catálogo ilustrado de componentes.

Según la disponibilidad y la situación geográfica, los componentes CSR se enviarán para que lleguen a su destino al siguiente día laborable. Si la situación geográfica lo permite, se puede solicitar la entrega en el mismo día o en cuatro horas con un coste adicional. Si precisa asistencia técnica, puede llamar al Centro de asistencia técnica de Hewlett Packard Enterprise y recibirá ayuda telefónica por parte de un técnico. Con el envío de materiales para la sustitución de componentes CSR, Hewlett Packard Enterprise especificará si los componentes defectuosos deberán devolverse a Hewlett Packard Enterprise. En aquellos casos en los que sea necesario devolver algún componente a Hewlett Packard Enterprise,



deberá hacerlo en el periodo de tiempo especificado, normalmente cinco días laborables. Los componentes defectuosos deberán devolverse con toda la documentación relacionada y con el embalaje de envío. Si no enviara el componente defectuoso requerido, Hewlett Packard Enterprise podrá cobrarle por el de sustitución. En el caso de todas sustituciones que lleve a cabo el cliente, Hewlett Packard Enterprise se hará cargo de todos los gastos de envío y devolución de componentes y escogerá la empresa de transporte que se utilice para dicho servicio.

Para obtener más información acerca del programa de Reparaciones del propio cliente de Hewlett Packard Enterprise, póngase en contacto con su proveedor de servicios local. Si está interesado en el programa para Norteamérica, visite la página web de Hewlett Packard Enterprise CSR (<http://www.hpe.com/support/selfrepair>).

## Servicio de garantía exclusivo de componentes

La garantía limitada de Hewlett Packard Enterprise puede que incluya un servicio de garantía exclusivo de componentes. Según las condiciones de este servicio exclusivo de componentes, Hewlett Packard Enterprise le facilitará los componentes de repuesto sin cargo adicional alguno.

Para este servicio de garantía exclusivo de componentes, es obligatoria la sustitución de componentes por parte del usuario (CSR). Si solicita a Hewlett Packard Enterprise que realice la sustitución de estos componentes, tendrá que hacerse cargo de los gastos de desplazamiento y de mano de obra de dicho servicio.

## Customer Self Repair

Veel onderdelen in Hewlett Packard Enterprise producten zijn door de klant zelf te repareren, waardoor de reparatieduur tot een minimum beperkt kan blijven en de flexibiliteit in het vervangen van defecte onderdelen groter is. Deze onderdelen worden CSR-onderdelen (Customer Self Repair) genoemd. Als Hewlett Packard Enterprise (of een Hewlett Packard Enterprise Service Partner) bij de diagnose vaststelt dat de reparatie kan worden uitgevoerd met een CSR-onderdeel, verzendt Hewlett Packard Enterprise dat onderdeel rechtstreeks naar u, zodat u het defecte onderdeel daarmee kunt vervangen. Er zijn twee categorieën CSR-onderdelen:

- **Verplicht**—Onderdelen waarvoor reparatie door de klant verplicht is. Als u Hewlett Packard Enterprise verzoekt deze onderdelen voor u te vervangen, worden u voor deze service reiskosten en arbeidsloon in rekening gebracht.
- **Optioneel**—Onderdelen waarvoor reparatie door de klant optioneel is. Ook deze onderdelen zijn ontworpen voor reparatie door de klant. Als u echter Hewlett Packard Enterprise verzoekt deze onderdelen voor u te vervangen, kunnen daarvoor extra kosten in rekening worden gebracht, afhankelijk van het type garantieservice voor het product.

**OPMERKING:** Sommige Hewlett Packard Enterprise onderdelen zijn niet ontwikkeld voor reparatie door de klant. In verband met de garantievoorwaarden moet het onderdeel door een geautoriseerde Service Partner worden vervangen. Deze onderdelen worden in de geïllustreerde onderdelencatalogus aangemerkt met "Nee".

Afhankelijk van de leverbaarheid en de locatie worden CSR-onderdelen verzonden voor levering op de eerstvolgende werkdag. Levering op dezelfde dag of binnen vier uur kan tegen meerkosten worden aangeboden, indien dit mogelijk is gezien de locatie. Indien assistentie is gewenst, belt u het Hewlett Packard Enterprise Support Center om via de telefoon ondersteuning van een technicus te ontvangen. Hewlett Packard Enterprise vermeldt in de documentatie bij het vervangende CSR-onderdeel of het defecte onderdeel aan Hewlett Packard Enterprise moet worden geretourneerd. Als het defecte onderdeel aan Hewlett Packard Enterprise moet worden teruggezonden, moet u het defecte onderdeel binnen een bepaalde periode, gewoonlijk vijf (5) werkdagen, retourneren aan Hewlett Packard Enterprise. Het defecte onderdeel moet met de bijbehorende documentatie worden geretourneerd in het meegeleverde verpakkingsmateriaal. Als u het defecte onderdeel niet terugzendt, kan Hewlett Packard

Enterprise u voor het vervangende onderdeel kosten in rekening brengen. Bij reparatie door de klant betaalt Hewlett Packard Enterprise alle verzendkosten voor het vervangende en geretourneerde onderdeel en kiest Hewlett Packard Enterprise zelf welke koerier/transportonderneming hiervoor wordt gebruikt.

Neem contact op met een Service Partner voor meer informatie over het Customer Self Repair programma van Hewlett Packard Enterprise. Informatie over Service Partners vindt u op de Hewlett Packard Enterprise website (<http://www.hpe.com/support/selfrepair>).

## Garantieservice "Parts Only"

Het is mogelijk dat de Hewlett Packard Enterprise garantie alleen de garantieservice "Parts Only" omvat. Volgens de bepalingen van de Parts Only garantieservice zal Hewlett Packard Enterprise kosteloos vervangende onderdelen ter beschikking stellen.

Voor de Parts Only garantieservice is vervanging door CSR-onderdelen verplicht. Als u Hewlett Packard Enterprise verzoekt deze onderdelen voor u te vervangen, worden u voor deze service reiskosten en arbeidsloon in rekening gebracht

## Reparo feito pelo cliente

Os produtos da Hewlett Packard Enterprise são projetados com muitas peças para reparo feito pelo cliente (CSR) de modo a minimizar o tempo de reparo e permitir maior flexibilidade na substituição de peças com defeito. Se, durante o período de diagnóstico, a Hewlett Packard Enterprise (ou fornecedores/parceiros da Hewlett Packard Enterprise) concluir que o reparo pode ser efetuado pelo uso de uma peça CSR, a Hewlett Packard Enterprise enviará a peça diretamente ao cliente. Há duas categorias de peças CSR:

- **Obrigatória**—Peças cujo reparo feito pelo cliente é obrigatório. Se desejar que a Hewlett Packard Enterprise substitua essas peças, serão cobradas as despesas de transporte e mão-de-obra do serviço.
- **Opcional**—Peças cujo reparo feito pelo cliente é opcional. Essas peças também são projetadas para o reparo feito pelo cliente. No entanto, se desejar que a Hewlett Packard Enterprise as substitua, pode haver ou não a cobrança de taxa adicional, dependendo do tipo de serviço de garantia destinado ao produto.

**OBSERVAÇÃO:** Algumas peças da Hewlett Packard Enterprise não são projetadas para o reparo feito pelo cliente. A fim de cumprir a garantia do cliente, a Hewlett Packard Enterprise exige que um técnico autorizado substitua a peça. Essas peças estão identificadas com a marca "No" (Não), no catálogo de peças ilustrado.

Conforme a disponibilidade e o local geográfico, as peças CSR serão enviadas no primeiro dia útil após o pedido. Onde as condições geográficas permitirem, a entrega no mesmo dia ou em quatro horas pode ser feita mediante uma taxa adicional. Se precisar de auxílio, entre em contato com o Centro de suporte técnico da Hewlett Packard Enterprise para que um técnico o ajude por telefone. A Hewlett Packard Enterprise especifica nos materiais fornecidos com a peça CSR de reposição se a peça com defeito deve ser devolvida à Hewlett Packard Enterprise. Nos casos em que isso for necessário, é preciso enviar a peça com defeito à Hewlett Packard Enterprise, você deverá enviar a peça com defeito de volta para a Hewlett Packard Enterprise dentro do período de tempo definido, normalmente em 5 (cinco) dias úteis. A peça com defeito deve ser enviada com a documentação correspondente no material de transporte fornecido. Caso não o faça, a Hewlett Packard Enterprise poderá cobrar a reposição. Para as peças de reparo feito pelo cliente, a Hewlett Packard Enterprise paga todas as despesas de transporte e de devolução da peça e determina a transportadora/serviço postal a ser utilizado.

Para obter mais informações sobre o programa de reparo feito pelo cliente da Hewlett Packard Enterprise, entre em contato com o fornecedor de serviços local. Para o programa norte-americano, visite o site da Hewlett Packard Enterprise (<http://www.hpe.com/support/selfrepair>).

## Serviço de garantia apenas para peças

A garantia limitada da Hewlett Packard Enterprise pode incluir um serviço de garantia apenas para peças. Segundo os termos do serviço de garantia apenas para peças, a Hewlett Packard Enterprise fornece as peças de reposição sem cobrar nenhuma taxa.

No caso desse serviço, a substituição de peças CSR é obrigatória. Se desejar que a Hewlett Packard Enterprise substitua essas peças, serão cobradas as despesas de transporte e mão-de-obra do serviço.

## カスタマーセルフリペア

修理時間を短縮し、故障部品の交換における高い柔軟性を確保するために、Hewlett Packard Enterprise製品には多数のカスタマーセルフリペア（CSR）部品があります。診断の際に、CSR部品を使用すれば修理ができるとHewlett Packard Enterprise（Hewlett Packard EnterpriseまたはHewlett Packard Enterprise正規保守代理店）が判断した場合、Hewlett Packard Enterpriseはその部品を直接、お客様に発送し、お客様に交換していただきます。CSR部品には以下の2種類があります。

- **必須** - カスタマーセルフリペアが必須の部品。当該部品について、もしもお客様がHewlett Packard Enterpriseに交換作業を依頼される場合には、その修理サービスに関する交通費および人件費がお客様に請求されます。
- **任意** - カスタマーセルフリペアが任意である部品。この部品もカスタマーセルフリペア用です。当該部品について、もしもお客様がHewlett Packard Enterpriseに交換作業を依頼される場合には、お買い上げの製品に適用される保証サービス内容の範囲内においては、別途費用を負担していただくことなく保証サービスを受けることができます。

注：Hewlett Packard Enterprise製品の一部の部品は、カスタマーセルフリペアの対象外です。製品の保証を継続するためには、Hewlett Packard EnterpriseまたはHewlett Packard Enterprise正規保守代理店による交換作業が必須となります。部品カタログには、当該部品がカスタマーセルフリペア除外品である旨が記載されています。

部品供給が可能な場合、地域によっては、CSR部品を翌営業日に届くように発送します。また、地域によっては、追加費用を負担いただくことにより同日または4時間以内に届くように発送することも可能な場合があります。サポートが必要なときは、Hewlett Packard Enterpriseサポートセンターに電話していただければ、技術者が電話でアドバイスします。交換用のCSR部品または同梱物には、故障部品をHewlett Packard Enterpriseに返送する必要がある場合、指定期限内（通常は5営業日以内）に故障部品をHewlett Packard Enterpriseに返送してください。故障部品を返送する場合は、届いた時の梱包箱に関連書類とともにに入れてください。故障部品を返送しない場合、Hewlett Packard Enterpriseから部品費用が請求されます。カスタマーセルフリペアの際には、Hewlett Packard Enterpriseは送料および部品返送費を全額負担し、使用する宅配便会社や運送会社を指定します。

## 部品のみ保証サービス

Hewlett Packard Enterprise保証サービスには、部品のみ保証サービスが適用される場合があります。このサービスでは、交換部品は無償で提供されます。

部品のみ保証サービスにおいては、CSR部品をお客様により交換作業していただくことが必須となります。当該部品について、もしもお客様がHewlett Packard Enterpriseに交換作業を依頼される場合には、その修理サービスに関する交通費および人件費がお客様のご負担となります。

# 客户自行维修

Hewlett Packard Enterprise 产品提供许多客户自行维修 (CSR) 部件，以尽可能缩短维修时间和在更换缺陷部件方面提供更大的灵活性。如果在诊断期间 Hewlett Packard Enterprise (或 Hewlett Packard Enterprise 服务提供商或服务合作伙伴) 确定可以通过使用 CSR 部件完成维修，Hewlett Packard Enterprise 将直接把该部件发送给您进行更换。有两类 CSR 部件：

- **强制性的** — 要求客户必须自行维修的部件。如果您请求 Hewlett Packard Enterprise 更换这些部件，则必须为该服务支付差旅费和人工费用。
- **可选的** — 客户可以选择是否自行维修的部件。这些部件也是为客户自行维修设计的。不过，如果您要求 Hewlett Packard Enterprise 为您更换这些部件，则根据为您的产品指定的保修服务类型，Hewlett Packard Enterprise 可能收取或不再收取任何附加费用。

**注：**某些 Hewlett Packard Enterprise 部件的设计并未考虑客户自行维修。为了满足客户保修的需要，Hewlett Packard Enterprise 要求授权服务提供商更换相关部件。这些部件在部件图解目录中标记为“否”。

CSR 部件将在下一个工作日发运 (取决于备货情况和允许的地理范围)。在允许的地理范围内，可在当天或四小时内发运，但要收取额外费用。如果需要帮助，您可以致电 Hewlett Packard Enterprise 技术支持中心，将会有技术人员通过电话为您提供帮助。Hewlett Packard Enterprise 会在随更换的 CSR 部件发运的材料中指明是否必须将有缺陷的部件返还给 Hewlett Packard Enterprise。如果要求您将有缺陷的部件返还给 Hewlett Packard Enterprise，那么您必须在规定的期限内 (通常是五 (5) 个工作日) 将缺陷部件发给 Hewlett Packard Enterprise。有缺陷的部件必须随所提供的发运材料中的相关文件一起返还。如果未能送还有缺陷的部件，Hewlett Packard Enterprise 可能会要求您支付更换费用。客户自行维修时，Hewlett Packard Enterprise 将承担所有相关运输和部件返回费用，并指定快递商/承运商。

有关 Hewlett Packard Enterprise 客户自行维修计划的详细信息，请与您当地的服务提供商联系。有关北美地区的计划，请访问 Hewlett Packard Enterprise 网站 (<http://www.hpe.com/support/selfrepair>)。

## 仅部件保修服务

您的 Hewlett Packard Enterprise 有限保修服务可能涉及仅部件保修服务。根据仅部件保修服务条款的规定，Hewlett Packard Enterprise 将免费提供更换的部件。

仅部件保修服务要求进行 CSR 部件更换。如果您请求 Hewlett Packard Enterprise 更换这些部件，则必须为该服务支付差旅费和人工费用。

# 客戶自行維修

Hewlett Packard Enterprise 產品設計了許多「客戶自行維修」(CSR) 的零件以減少維修時間，並且使得更換瑕疵零件時能有更大的彈性。如果在診斷期間，Hewlett Packard Enterprise (或 Hewlett Packard Enterprise 服務供應商或維修夥伴) 辨認出此項維修工作可以藉由使用 CSR 零件來完成，則 Hewlett Packard Enterprise 將直接寄送該零件給您作更換。CSR 零件分為兩種類別：

- **強制的** — 客戶自行維修所使用的零件是強制性的。如果您要求 Hewlett Packard Enterprise 更換這些零件，Hewlett Packard Enterprise 將會向您收取此服務所需的外出費用與勞動成本。
- **選購的** — 客戶自行維修所使用的零件是選購的。這些零件也設計用於客戶自行維修之用。不過，如果您要求 Hewlett Packard Enterprise 為您更換，則可能需要也可能不需要負擔額外的費用，端視針對此產品指定的保固服務類型而定。

**備註：**某些 Hewlett Packard Enterprise 零件沒有消費者可自行維修的設計。為符合客戶保固，Hewlett Packard Enterprise 需要授權的服務供應商更換零件。這些零件在圖示的零件目錄中，被標示為「否」。

基於材料取得及環境允許的情況下，CSR 零件將於下一個工作日以快遞寄送。在環境的允許下當天或四小時內送達，則可能需要額外的費用。若您需要協助，可致電 Hewlett Packard Enterprise 支援中心，會有一位技術人員透過電話來協助您。不論損壞的零件是否必須退回，Hewlett Packard Enterprise 皆會在與 CSR 替換零件一起運送的材料中註明。若要將損壞的零件退回 Hewlett Packard Enterprise，您必須在指定的一段時間內 (通常為五 (5) 個工作天)，將損壞的零件寄回 Hewlett Packard Enterprise。損壞的零件必須與寄送資料中隨附的相關技術文件一併退還。如果無法退還損壞的零件，Hewlett Packard Enterprise 可能要向您收取替換費用。針對客戶自行維修情形，Hewlett Packard Enterprise 將負責所有運費及零件退還費用，並指定使用何家快遞/貨運公司。

如需 Hewlett Packard Enterprise 的 CSR 方案詳細資訊，請連絡您當地的服務供應商。至於北美方案，請參閱 Hewlett Packard Enterprise 的 CSR 網站repair (<http://www.hpe.com/support/selfrepair>)。

## 僅限零件的保固服務

您的「Hewlett Packard Enterprise 有限保固」可能包含僅限零件的保固服務。在僅限零件的保固服務情況下，Hewlett Packard Enterprise 將免費提供替換零件。

針對僅限零件的保固服務，CSR 零件替換是強制性的。如果您要求 Hewlett Packard Enterprise 更換這些零件，Hewlett Packard Enterprise 將會向您收取此服務所需的外出費用與勞動成本。

## 고객 셀프 수리

Hewlett Packard Enterprise 제품은 수리 시간을 최소화하고 결함이 있는 부품 교체 시 더욱 용동성을 발휘할 수 있도록 하기 위해 고객 셀프 수리(CSR) 부품을 다량 사용하여 설계되었습니다. 진단 기간 동안 Hewlett Packard Enterprise(또는 Hewlett Packard Enterprise 서비스 공급업체 또는 서비스 협력업체)에서 CSR 부품을 사용하여 수리가 가능하다고 판단되면 Hewlett Packard Enterprise는 해당 부품을 바로 사용자에게 보내어 사용자가 교체할 수 있도록 합니다. CSR 부품에는 두 가지 종류가 있습니다.

- 필수 - 고객 셀프 수리가 의무 사항인 필수 부품. 사용자가 Hewlett Packard Enterprise에 이 부품의 교체를 요청할 경우 이 서비스에 대한 출장비 및 작업비가 청구됩니다.
- 선택 사항 - 고객 셀프 수리가 선택 사항인 부품. 이 부품들도 고객 셀프 수리가 가능하도록 설계되었습니다. 하지만 사용자가 Hewlett Packard Enterprise에 이 부품의 교체를 요청할 경우 사용자가 구입한 제품에 해당하는 보증 서비스 유형에 따라 추가 비용 없이 교체가 가능할 수 있습니다.

참고: 일부 Hewlett Packard Enterprise 부품은 고객 셀프 수리가 불가능하도록 설계되었습니다. Hewlett Packard Enterprise는 만족스러운 고객 보증을 위해 공인 서비스 제공업체를 통해 부품을 교체하도록 하고 있습니다. 이러한 부품들은 Illustrated Parts Catalog에 "No"라고 표시되어 있습니다.

CSR 부품은 재고 상태와 지리적 조건이 허용하는 경우 다음 영업일 납품이 가능하도록 배송이 이루어집니다. 지리적 조건이 허용하는 경우 추가 비용이 청구되는 조건으로 당일 또는 4시간 배송이 가능할 수도 있습니다. 도움이 필요하시면 Hewlett Packard Enterprise Support Center로 전화하십시오. 전문 기술자가 전화로 도움을 줄 것입니다. Hewlett Packard Enterprise는 결함이 발생한 부품을 Hewlett Packard Enterprise로 반환해야 하는지 여부를 CSR 교체 부품과 함께 배송된 자료에 지정합니다. 결함이 발생한 부품을 Hewlett Packard Enterprise로 반환해야 하는 경우에는 지정된 기간 내(통상 영업일 기준 5일)에 Hewlett Packard Enterprise로 반환해야 합니다. 이때 결함이 발생한 부품은 제공된 포장 재료에 넣어 관련 설명서와 함께 반환해야 합니다. 결함이 발생한 부품을 반환하지 않는 경우 Hewlett Packard Enterprise가 교체 부품에 대해 비용을 청구할 수 있습니다. 고객 셀프 수리의 경우, Hewlett Packard Enterprise는 모든 운송 및 부품 반환 비용을 부담하며 이용할 운송업체 및 택배 서비스를 결정합니다.

Hewlett Packard Enterprise CSR 프로그램에 대한 자세한 내용은 가까운 서비스 제공업체에 문의하십시오. 북미 지역의 프로그램에 대해서는 Hewlett Packard Enterprise CSR 웹 사이트(<http://www.hpe.com/support/selfrepair>)를 참조하십시오.

## 부품 제공 보증 서비스

Hewlett Packard Enterprise 제한 보증에는 부품 제공 보증 서비스가 포함될 수 있습니다. 이러한 경우 Hewlett Packard Enterprise는 부품 제공 보증 서비스의 조건에 따라 교체 부품만을 무료로 제공합니다.

부품 제공 보증 서비스 제공 시 CSR 부품 교체는 의무 사항입니다. 사용자가 Hewlett Packard Enterprise에 이 부품의 교체를 요청할 경우 이 서비스에 대한 출장비 및 작업비가 청구됩니다.



<b>Item</b>	<b>Description</b>	<b>Spare part number</b>	<b>Customer self repair (on page 5)</b>
	j) 2.30 GHz Intel Xeon E5-2650 v3, 105W* **	762448-001	Optional <sup>2</sup>
	k) 2.60 GHz Intel Xeon E5-2660 v3, 105W* **	762449-001	Optional <sup>2</sup>
	l) 2.30 GHz Intel Xeon E5-2670 v3, 120W* **	762450-001	Optional <sup>2</sup>
	m) 2.50 GHz Intel Xeon E5-2680 v3, 120W* **	762451-001	Optional <sup>2</sup>
	n) 2.00 GHz Intel Xeon E5-2683 v3, 120W* **	762453-001	Optional <sup>2</sup>
	o) 2.60 GHz Intel Xeon E5-2690 v3, 135W* **	762452-001	Optional <sup>2</sup>
	p) 2.30 GHz Intel Xeon E5-2695 v3, 120W* **	762454-001	Optional <sup>2</sup>
	q) 2.30 GHz Intel Xeon E5-2698 v3, 135W* **	780760-001	Optional <sup>2</sup>
	r) 1.7-GHz Intel Xeon E5-2603 v4* **	835599-001	Optional <sup>2</sup>
	s) 1.7-GHz Intel Xeon E5-2609 v4* **	835600-001	Optional <sup>2</sup>
	t) 1.7-GHz Intel Xeon E5-2620 v4* **	835601-001	Optional <sup>2</sup>
	u) 2.2-GHz Intel Xeon E5-2630 v4* **	835602-001	Optional <sup>2</sup>
	v) 2.4-GHz Intel Xeon E5-2640 v4* **	835603-001	Optional <sup>2</sup>
	w) 2.2-GHz Intel Xeon E5-2650 v4* **	835604-001	Optional <sup>2</sup>
	x) 2.0-GHz Intel Xeon E5-2660 v4* **	835605-001	Optional <sup>2</sup>
	y) 2.4-GHz Intel Xeon E5-2680 v4* **	835606-001	Optional <sup>2</sup>
	z) 2.6-GHz Intel Xeon E5-2690 v4* **	835607-001	Optional <sup>2</sup>
	aa) 2.6-GHz Intel Xeon E5-2623 v4* **	835610-001	Optional <sup>2</sup>
	bb) 3.2-GHz Intel Xeon E5-2643 v4* **	835612-001	Optional <sup>2</sup>
	cc) 2.9-GHz Intel Xeon E5-2667 v4* **	835613-001	Optional <sup>2</sup>
	dd) 2.1-GHz Intel Xeon E5-2683 v4* **	835614-001	Optional <sup>2</sup>
	ee) 2.1-GHz Intel Xeon E5-2695 v4* **	835615-001	Optional <sup>2</sup>
	ff) 2.3-GHz Intel Xeon E5-2697 v4* **	835616-001	Optional <sup>2</sup>
	gg) 2.2-GHz Intel Xeon E5-2698 v4* **	835617-001	Optional <sup>2</sup>
	hh) 2.2-GHz Intel Xeon E5-2699 v4* **	835618-001	Optional <sup>2</sup>
	ii) 2.4-GHz Intel Xeon E5-2699A v4* **	872020-001	Optional <sup>2</sup>
	jj) 2.2-GHz Intel Xeon E5-2697A v4* **	841035-001	Optional <sup>2</sup>
<b>5</b>	Heatsink	779142-001	Optional <sup>2</sup>
<b>6</b>	Drive cage assembly	—	—
	a) Drive cage assembly with two 6-GB drive backplanes	774723-001	Mandatory <sup>1</sup>
	b) Drive cage assembly with two 6-GB drive backplanes, front panel LED board assembly, and front panel LED board assembly cables*	789882-001	Mandatory <sup>1</sup>
	c) Drive cage assembly with a single 12-GB drive backplane, front panel LED board assembly, and front panel LED board assembly cables*	794875-001	Mandatory <sup>1</sup>
	d) Drive cage assembly, non-hot-plug, including front panel LED board assembly, and front panel LED board assembly cables*	787326-001	Mandatory <sup>1</sup>



<b>Item</b>	<b>Description</b>	<b>Spare part number</b>	<b>Customer self repair (on page 5)</b>
7	PCI riser board assembly with PCIe riser board	784717-001	Optional <sup>2</sup>
8	System battery*	234556-001	Mandatory <sup>1</sup>
9	DIMMs	—	—
	a) 8-GB, single-rank, PC4-2133R	774170-001	Mandatory <sup>1</sup>
	b) 8-GB, dual-rank, PC4-2133R*	774171-001	Mandatory <sup>1</sup>
	c) 16-GB, dual-rank, PC4-2133P*	812221-001	Mandatory <sup>1</sup>
	d) 16-GB, dual-rank, PC4-2133L*	774173-001	Mandatory <sup>1</sup>
	e) 32-GB, dual-rank, PC4-2133R*	774175-001	Mandatory <sup>1</sup>
	f) 32-GB, quad-rank, PC4-2133L*	774174-001	Mandatory <sup>1</sup>
	g) 8-GB, single-rank, PC4-2400T-R*	844948-001	Mandatory <sup>1</sup>
	h) 16-GB, single-rank, PC4-2400T-R*	844949-001	Mandatory <sup>1</sup>
	i) 16-GB, dual-rank, PC4-2400T-R*	846740-001	Mandatory <sup>1</sup>
	j) 32-GB, dual-rank, PC4-2400T-R*	844950-001	Mandatory <sup>1</sup>
	k) 32-GB, dual-rank, PC4-2400T-L*	819414-001	Mandatory <sup>1</sup>
	l) 64-GB, quad-rank, PC4-2400T-L*	819413-001	Mandatory <sup>1</sup>
10	Front panel LED board assembly	779137-001	Optional <sup>2</sup>
11	System board	—	—
	a) System board with 6-GB drive backplane support (E5-26XXv3)	779133-001	Optional <sup>2</sup>
	b) System board with 12-GB drive backplane support (E5-26XXv3)*	786718-001	Optional <sup>2</sup>
	c) System board with 12-GB drive backplane support (E5-26XXv4)*	834374-001	Optional <sup>2</sup>
12	SFF drives	—	—
	a) 2.0-T SAS HDD, 12G, 7,200 rpm	765873-001	Mandatory <sup>1</sup>
	b) 2.0-T SATA HDD, 6G, 7,200 rpm*	765869-001	Mandatory <sup>1</sup>
	c) 1.8-T SAS HDD, 12G, 10,000 rpm*	791055-001	Mandatory <sup>1</sup>
	d) 1.2-T SAS HDD, 12G, 10,000 rpm*	781578-001	Mandatory <sup>1</sup>
	e) 1.0-T SAS HDD, 12G, 7,200 rpm*	653954-001	Mandatory <sup>1</sup>
	f) 1.0-T SATA HDD, 6G, 7,200 rpm*	752672-001	Mandatory <sup>1</sup>
	g) 1.0-T SAS HDD, 6G, 10,000 rpm*	765872-001	Mandatory <sup>1</sup>
	h) 1.0-T SATA HDD, 6G, 7,200 rpm*	656108-001	Mandatory <sup>1</sup>
	i) 1.0-T SATA HDD, 6G, 7,200 rpm*	765868-001	Mandatory <sup>1</sup>
	j) 900-GB SAS HDD, 12G, 10,000 rpm*	785411-001	Mandatory <sup>1</sup>
	k) 900-GB SAS HDD, 6G, 10,000 rpm*	653971-001	Mandatory <sup>1</sup>
	l) 600-GB SAS HDD, 12G, 10,000 rpm*	781577-001	Mandatory <sup>1</sup>

<b>Item</b>	<b>Description</b>	<b>Spare part number</b>	<b>Customer self repair (on page 5)</b>
m)	600-GB SAS HDD, 6G, 10,000 rpm*	653957-001	Mandatory <sup>1</sup>
n)	500-GB SAS HDD, 6G, 7,200 rpm*	752671-001	Mandatory <sup>1</sup>
o)	500-GB SAS HDD, 6G, 7,200 rpm*	653953-001	Mandatory <sup>1</sup>
p)	500-GB SATA HDD, 7,200 rpm*	656107-001	Mandatory <sup>1</sup>
q)	450-GB SAS HDD, 6G, 10,000 rpm*	653956-001	Mandatory <sup>1</sup>
r)	300-GB SAS HDD, 12G, 10,000 rpm*	785410-001	Mandatory <sup>1</sup>
s)	300-GB SAS HDD, 6G, 10,000 rpm*	653955-001	Mandatory <sup>1</sup>
t)	300-GB SAS HDD, 6G, 15,000 rpm*	653960-001	Mandatory <sup>1</sup>
u)	1.92-T SAS SSD, 12G, VE*	802911-001	Mandatory <sup>1</sup>
v)	1.92-T SAS SSD, 6G, RI*	838447-001	Mandatory <sup>1</sup>
w)	1.6-T SAS SSD, 12G, MLC, VE*	780436-001	Mandatory <sup>1</sup>
x)	1.6-T SAS SSD, 12G, WI*	846623-001	Mandatory <sup>1</sup>
y)	1.6-T SAS SSD, 12G MU*	846625-001	Mandatory <sup>1</sup>
z)	960-GB SAS SSD, 6G, RI*	838446-001	Mandatory <sup>1</sup>
aa)	800-GB SAS SSD, 12G, MLC*	780434-001	Mandatory <sup>1</sup>
bb)	800-GB SAS SSD, 12G, ME*	741228-001	Mandatory <sup>1</sup>
cc)	800-GB SAS SSD, 12G HE*	802909-001	Mandatory <sup>1</sup>
dd)	800-GB SAS SSD, 12G, HE*	741234-001	Mandatory <sup>1</sup>
ee)	800-GB SAS SSD, 12G, WI*	846622-001	Mandatory <sup>1</sup>
ff)	800-GB SAS SSD, 12G, MU*	846625-001	Mandatory <sup>1</sup>
gg)	800-GB SATA SSD, MLC*	692167-001	Mandatory <sup>1</sup>
hh)	600-GB SATA SSD, 6G, VE*	739959-001	Mandatory <sup>1</sup>
ii)	480-GB SAS SSD, 6G, RI*	838445-001	Mandatory <sup>1</sup>
jj)	400-GB SAS SSD, 12G, MLC*	780432-001	Mandatory <sup>1</sup>
kk)	400-GB SAS SSD, 12G, ME*	741226-001	Mandatory <sup>1</sup>
ll)	400-GB SAS SSD, 12G, HE*	802907-001	Mandatory <sup>1</sup>
mm)	400-GB SAS SSD, 12G, HE*	741232-001	Mandatory <sup>1</sup>
nn)	400-GB SATA SSD, MLC*	692166-001	Mandatory <sup>1</sup>
oo)	300-GB SATA SSD, 6G, VE*	739954-001	Mandatory <sup>1</sup>
pp)	240-GB SATA SSD, 6G, RI*	838444-001	Mandatory <sup>1</sup>
qq)	200-GB SATA SSD, 12G, MLC, VE*	780430-001	Mandatory <sup>1</sup>
rr)	200-GB SATA SSD, MLC*	692165-001	Mandatory <sup>1</sup>
ss)	200-GB SAS SSD, 12G, ME*	741224-001	Mandatory <sup>1</sup>

Item	Description	Spare part number	Customer self repair (on page 5)
	tt) 200-GB SAS SSD, 12G, HE*	741230-001	Mandatory <sup>1</sup>
	uu) 200-GB SAS SSD, 12G, HE*	802905-001	Mandatory <sup>1</sup>
	vv) 120-GB SAS SSD, 6G, RI*	838443-001	Mandatory <sup>1</sup>
	ww) 100-GB 2.5 SATA SC MLC*	692164-001	Mandatory <sup>1</sup>
13	PCIe expansion board options	—	—
	a) HPE H240 Smart Host Bus Adapter	779134-001	Optional <sup>2</sup>
	b) HPE Smart Array P440 Controller*	749797-001	Optional <sup>2</sup>
	c) HPE InfiniBand FDR 2-port 545FLR-QSFP Adapter*	705088-001	Optional <sup>2</sup>
	d) 1.0-TB PCIe I/O accelerator, LE*	775677-001	No <sup>3</sup>
	e) 1.3-TB PCIe I/O accelerator, MLC*	764125-001	No <sup>3</sup>
	f) 1.6-TB PCIe I/O accelerator, MLC*	764126-001	No <sup>3</sup>
	g) 2.6-TB PCIe I/O accelerator, LE*	775679-001	No <sup>3</sup>
	h) 3.2-TB PCIe I/O accelerator, MLC*	764127-001	No <sup>3</sup>
	i) HPE H241 Smart Host Bus Adapter*	750054-001	No <sup>3</sup>
14	HPE Smart Storage Battery with cable, 12W*	827350-001	Mandatory <sup>1</sup>
15	Trusted Platform Module*	—	—
	a) Trusted Platform Module 1.0	505836-001	No <sup>3</sup>
	b) Trusted Platform Module 2.0	812119-001	No <sup>3</sup>
16	Cables	—	—
	a) Mini-SAS cable, 260 mm (10.24 in), 6-GB backplane on drive box 1*	779135-001	Mandatory <sup>1</sup>
	b) Mini-SAS cable, 285 mm (11.22 in), 6-GB backplane on drive box 2*	747029-001	Mandatory <sup>1</sup>
	c) Mini-SAS cable, 12-GB backplane with embedded controller*	799415-001	Mandatory <sup>1</sup>
	d) Mini-SAS cable, 12-GB backplane with HPE H240 Smart Host Bus Adapter*	799198-001	Mandatory <sup>1</sup>
	e) Mini-SAS cable, 12-GB backplane with HPE Smart Array P440 Controller*	796134-001	Mandatory <sup>1</sup>
	f) Mini-SAS cable, 12-GB backplane with HPE Smart Array P440 Controller*	787327-001	Mandatory <sup>1</sup>
	g) Drive power cable, 310 mm (12.20 in), 6-GB backplane on drive box 1*	786715-001	Mandatory <sup>1</sup>
	h) Drive power cable, 150 mm (5.91 in), 6-GB backplane on drive box 2*	786714-001	Mandatory <sup>1</sup>
	i) Drive power cable, 400 mm (15.75 in), 12-GB backplane with HPE Smart Array P440 Controller*	792837-001	Mandatory <sup>1</sup>
	j) Drive power cable, 300 mm (11.81 in), 12-GB backplane with HPE Smart Array P440 Controller*	792836-001	Mandatory <sup>1</sup>
	k) Drive power and data cable, non-hot-plug		Mandatory <sup>1</sup>
17	HPE c-Class Blade SUV cable*	416003-001	Mandatory <sup>1</sup>

\*Not shown

\*\*All processors in this HPE ProLiant server must have the same cache size, speed, number of cores, and rated maximum power consumption.

<sup>1</sup>Mandatory—Parts for which customer self repair is mandatory. If you request Hewlett Packard Enterprise to replace these parts, you will be charged for the travel and labor costs of this service.

<sup>2</sup>Optional—Parts for which customer self repair is optional. These parts are also designed for customer self repair. If, however, you require that Hewlett Packard Enterprise replace them for you, there may or may not be additional charges, depending on the type of warranty service designated for your product.

<sup>3</sup>No—Some Hewlett Packard Enterprise parts are not designed for customer self repair. In order to satisfy the customer warranty, Hewlett Packard Enterprise requires that an authorized service provider replace the part. These parts are identified as "No" in the Illustrated Parts Catalog.

<sup>1</sup>Obligatoire—Pièces pour lesquelles le client doit procéder lui-même aux réparations. Si vous demandez à Hewlett Packard Enterprise de procéder au remplacement de ces pièces, les frais de transport et de main d'œuvre pour ce service vous seront facturés.

<sup>2</sup>Facultatif—Pièces pour lesquelles une réparation par le client est facultative. Ces pièces sont également conçues pour que le client puisse procéder lui-même aux réparations. Cependant, les frais supplémentaires engendrés par le remplacement de ces pièces par Hewlett Packard Enterprise dépendent du type de service de garantie désigné pour votre produit.

<sup>3</sup>Non—Certaines pièces Hewlett Packard Enterprise ne sont pas conçues pour être remplacées par le client. Afin de se conformer aux exigences de la garantie la garantie du client, Hewlett Packard Enterprise demande à un fournisseur de services agréé de procéder au remplacement de la pièce. Ces pièces sont signalées par le mot « Non » dans le Catalogue de pièces illustré.

<sup>1</sup>Obbligatorio—Parti per le quali il cliente è tenuto a effettuare autonomamente la riparazione. Se si richiede l'intervento di Hewlett Packard Enterprise per la sostituzione di queste parti, al cliente verranno addebitate le spese di viaggio e manodopera dell'operazione.

<sup>2</sup>Facoltativo—Parti per le quali la riparazione in autonomia da parte del cliente è facoltativa. Queste parti sono progettate per consentire anche la riparazione da parte del cliente. Tuttavia, se il cliente richiede l'intervento di Hewlett Packard Enterprise per la sostituzione, potrebbero essere addebitate spese aggiuntive a seconda del tipo di garanzia in assistenza previsto per il prodotto.

<sup>3</sup>No—Alcune parti Hewlett Packard Enterprise non sono progettate la riparazione in autonomia da parte del cliente. In base a quanto previsto dalla garanzia per il cliente, Hewlett Packard Enterprise richiede l'intervento di un tecnico autorizzato per la sostituzione della parte. Queste parti sono contrassegnate con "No" nel catalogo parti illustrato.

<sup>1</sup>Zwingend—Teile, für die das Customer Self Repair-Verfahren zwingend vorgegeben ist. Wenn Sie den Austausch dieser Teile von Hewlett Packard Enterprise vornehmen lassen, werden Ihnen die Anfahrt- und Arbeitskosten für diesen Service berechnet.

<sup>2</sup>Optional—Teile, für die das Customer Self Repair-Verfahren optional ist. Diese Teile sind auch für Customer Self Repair ausgelegt. Wenn Sie jedoch den Austausch dieser Teile von Hewlett Packard Enterprise vornehmen lassen möchten, können bei diesem Service je nach den für Ihr Produkt vorgesehenen Garantiebedingungen zusätzliche Kosten anfallen.

<sup>3</sup>Nein—Einige Hewlett Packard Enterprise Teile sind nicht für Customer Self Repair ausgelegt. Um den Garantieanspruch des Kunden zu erfüllen, muss das Teil von einem Hewlett Packard Enterprise Servicepartner ersetzt werden. Im illustrierten Teilekatalog sind diese Teile mit „No“ bzw. „Nein“ gekennzeichnet.

<sup>1</sup>Obligatorio—Componentes cuya reparación por parte del usuario es obligatoria. Si solicita a Hewlett Packard Enterprise que realice la sustitución de estos componentes, tendrá que hacerse cargo de los gastos de desplazamiento y de mano de obra de dicho servicio.

<sup>2</sup>Opcional—Componentes cuya reparación por parte del usuario es opcional. Estos componentes también están diseñados para que puedan ser reparados por el usuario. Sin embargo, si precisa que Hewlett Packard Enterprise realice su sustitución, puede o no conllevar costes adicionales, dependiendo del tipo de servicio de garantía correspondiente al producto.

<sup>3</sup>No—Algunos componentes de Hewlett Packard Enterprise no están diseñados para que puedan ser reparados por el usuario. Para que el usuario haga valer su garantía, Hewlett Packard Enterprise pone como condición que un proveedor de servicios autorizado realice la sustitución de estos componentes. Dichos componentes se identifican con la palabra "No" en el catálogo ilustrado de componentes.

<sup>1</sup>Verplicht—Onderdelen die de klant zelf moet vervangen. Als u Hewlett Packard Enterprise vraagt deze onderdelen te vervangen, worden er reis- en arbeidskosten voor deze service in rekening gebracht.

<sup>2</sup>Optioneel—Onderdelen die de klant zelf kan vervangen. Deze onderdelen zijn ook ontworpen om door de klant zelf te worden vervangen. Als u Hewlett Packard Enterprise verzoekt om deze te vervangen, kan het zijn dat hiervoor extra kosten in rekening worden gebracht, afhankelijk van het soort garantie dat op uw product van toepassing is.

<sup>3</sup>Geen—Sommige onderdelen van Hewlett Packard Enterprise zijn niet ontworpen om door de klant zelf te worden vervangen. Om te voldoen aan de garantievooraarden eist Hewlett Packard Enterprise dat een geautoriseerde

serviceverlener het onderdeel vervangt. Deze onderdelen worden aangeduid met 'Geen' in de geïllustreerde onderdelencatalogus.

<sup>1</sup>Obrigatório—Peças cujo reparo feito pelo cliente é obrigatório. Se desejar que a Hewlett Packard Enterprise substitua essas peças, serão cobradas as despesas de transporte e mão-de-obra do serviço.

<sup>2</sup>Opcional—Peças cujo reparo feito pelo cliente é opcional. Essas peças também são projetadas para o reparo feito pelo cliente. No entanto, se desejar que a Hewlett Packard Enterprise as substitua, pode haver ou não a cobrança de taxa adicional, dependendo do tipo de serviço de garantia destinado ao produto.

<sup>3</sup>Não—Algumas peças da Hewlett Packard Enterprise não são projetadas para o reparo feito pelo cliente. A fim de cumprir a garantia do cliente, a Hewlett Packard Enterprise exige que um técnico autorizado substitua a peça. Essas peças estão identificadas com a marca "No" (Não), no catálogo de peças ilustrado.

<sup>1</sup>Mandatory : 必須 — カスタマーセルフリペアが必須の部品。当該部品について、もしもお客様がHewlett Packard Enterpriseに交換作業を依頼される場合には、その修理サービスに関する交通費および人件費がお客様に請求されます。

<sup>2</sup>Optional : 任意 — カスタマーセルフリペアが任意である部品。この部品もカスタマーセルフリペア用です。当該部品について、もしもお客様がHewlett Packard Enterpriseに交換作業を依頼される場合には、お買い上げの製品に適用される保証サービス内容の範囲内においては、別途費用を負担していただくことなく保証サービスを受けることができます。

<sup>3</sup>No : 除外 — Hewlett Packard Enterprise製品の一部の部品は、カスタマーセルフリペアの対象外です。製品の保証を継続するためには、Hewlett Packard EnterpriseまたはHewlett Packard Enterprise正規保守代理店による交換作業が必須となります。部品カタログには、当該部品がカスタマーセルフリペア除外品である旨が記載されています。

<sup>1</sup>Mandatory — 客户必须自行维修的部件。如果您请求 Hewlett Packard Enterprise 更换这些部件，则必须为该服务支付差旅费和人工费用。

<sup>2</sup>Optional — 客户可以选择是否自行维修的部件。这些部件也是为客户自行维修设计的。不过，如果您要求 Hewlett Packard Enterprise 为您更换这些部件，则根据为您的产品指定的保修服务类型，Hewlett Packard Enterprise 可能收取或不再收取任何附加费用。

<sup>3</sup>No — 某些 Hewlett Packard Enterprise 部件的设计并未考虑客户自行维修。为了满足客户保修的需要，Hewlett Packard Enterprise 要求授权服务提供商更换相关部件。这些部件在部件图解目录中标记为“否”。

<sup>1</sup>Mandatory — 客戶自行維修所使用的零件是強制性的。如果您要求 Hewlett Packard Enterprise 更換這些零件，Hewlett Packard Enterprise 將會向您收取此服務所需的外出費用與勞動成本。

<sup>2</sup>Optional — 客戶自行維修所使用的零件是選購的。這些零件也設計用於客戶自行維修之用。不過，如果您要求 Hewlett Packard Enterprise 為您更換，則可能需要也可能不需要負擔額外的費用，端視針對此產品指定的保固服務類型而定。

<sup>3</sup>No — 某些 Hewlett Packard Enterprise 零件沒有消費者可自行維修的設計。為符合客戶保固，Hewlett Packard Enterprise 需要授權的服務供應商更換零件。這些零件在圖示的零件目錄中，被標示為「否」。

<sup>1</sup>Mandatory — 고객 셀프 수리가 의무 사항인 필수 부품. 사용자가 Hewlett Packard Enterprise에 이 부품의 교체를 요청할 경우 해당 서비스에 대한 출장비 및 작업비가 청구됩니다.

<sup>2</sup>Optional — 고객 셀프 수리가 선택 사항인 부품. 이러한 부품들도 고객 셀프 수리가 가능하도록 설계되었습니다. 하지만 사용자가 Hewlett Packard Enterprise에 이러한 부품의 교체를 요청할 경우 사용자가 구입한 제품에 해당하는 보증 서비스 유형에 따라 추가 비용 없이 교체가 가능할 수 있습니다.

<sup>3</sup>No — 일부 Hewlett Packard Enterprise 부품은 고객 셀프 수리가 불가능하도록 설계되었습니다. Hewlett Packard Enterprise는 만족스러운 고객 보증을 위해 공인 서비스 제공업체를 통해 부품을 교체하도록 요구하고 있습니다. 이러한 부품들은 Illustrated Parts Catalog에 "No"라고 표시되어 있습니다.

# I/O module components

Hewlett Packard Enterprise continually improves and changes product parts. For complete and current supported parts information, see the Hewlett Packard Enterprise PartSurfer website (<http://www.hpe.com/info/partsurfer>).

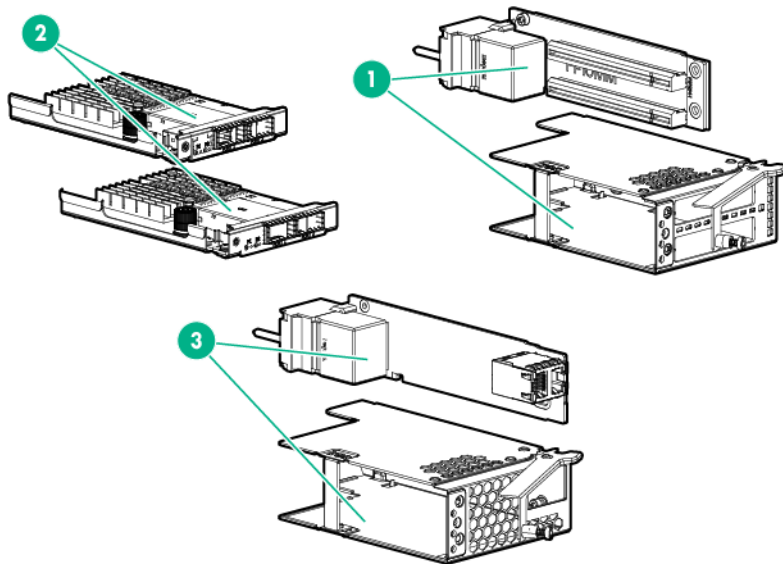

Item	Description	Spare part number	Customer self repair (on page 5)
1	HPE Apollo 6000 2 Slot FlexibleLOM Riser and I/O module	774720-001	Optional <sup>2</sup>
2	Dual FlexibleLOM I/O module adapter options	—	—
	a) HPE Flex Fabric 40-GB 2-port 544FLR Adapter	779132-001	Optional <sup>2</sup>
	b) HPE Flex Fabric 10-GB 2-port 544+ FLR Adapter*	764738-001	Optional <sup>2</sup>
	c) HPE Ethernet 1-GB 4-port 331FLR Adapter*	634025-001	Optional <sup>2</sup>
	d) HPE Ethernet 1-GB 4-port 366FLR Adapter*	669280-001	Optional <sup>2</sup>
	e) HPE Ethernet 10Gb 2-port 561FLR-T Adapter*	701525-001	Optional <sup>2</sup>
	f) HPE FlexFabric 10Gb 2-port 534FLR-SFP+ Adapter*	701531-001	Optional <sup>2</sup>
	g) HPE FlexFabric 10Gb 2-port 533FLR-T Adapter*	701534-001	Optional <sup>2</sup>
	h) HPE FlexFabric 10Gb 2-port 546FLR-SFP+ Adapter*	790315-001	Optional <sup>2</sup>
	i) HPE FlexFabric 10Gb 2-port 546 SFP+ Adapter*	790314-001	Optional <sup>2</sup>
	j) HPE FlexFabric 10Gb 2P 556FLR-SFP+ Adapter*	764460-001	Optional <sup>2</sup>
3	HPE Ethernet Dual 1Gb 1-port 364i Adapter and I/O module	774721-001	Optional <sup>2</sup>
4	HPE Apollo 6000 PCIe/FlexibleLOM Riser and I/O module*	815417-001	Optional <sup>2</sup>
5	PCIe/FlexibleLOM I/O module adapter options*	—	—
	a) HPE StoreFabric SN1100E 15Gb Dual Port Fibre Channel Host Bus Adapter*	719212-001	Mandatory <sup>1</sup>
	b) HPE StoreFabric SN1100E 15Gb Single Port Fibre Channel Host Bus Adapter*	719211-001	Mandatory <sup>1</sup>
	c) HPE InfiniBand EDR/Ethernet 100GB 1-port 840QSFP28 Adapter	828107-001	Mandatory <sup>1</sup>

Item	Description	Spare part number	Customer self repair (on page 5)
	d) HPE InfiniBand EDR/Ethernet 100GB 2-port 840QSFP28 Adapter	828108-001	Mandatory <sup>1</sup>
6	I/O module blank*	774727-001	Mandatory <sup>1</sup>

\*Not shown

<sup>1</sup>Mandatory—Parts for which customer self repair is mandatory. If you request Hewlett Packard Enterprise to replace these parts, you will be charged for the travel and labor costs of this service.

<sup>2</sup>Optional—Parts for which customer self repair is optional. These parts are also designed for customer self repair. If, however, you require that Hewlett Packard Enterprise replace them for you, there may or may not be additional charges, depending on the type of warranty service designated for your product.

<sup>3</sup>No—Some Hewlett Packard Enterprise parts are not designed for customer self repair. In order to satisfy the customer warranty, Hewlett Packard Enterprise requires that an authorized service provider replace the part. These parts are identified as "No" in the Illustrated Parts Catalog.

<sup>1</sup>Obligatoire—Pièces pour lesquelles le client doit procéder lui-même aux réparations. Si vous demandez à Hewlett Packard Enterprise de procéder au remplacement de ces pièces, les frais de transport et de main d'œuvre pour ce service vous seront facturés.

<sup>2</sup>Facultatif—Pièces pour lesquelles une réparation par le client est facultative. Ces pièces sont également conçues pour que le client puisse procéder lui-même aux réparations. Cependant, les frais supplémentaires engendrés par le remplacement de ces pièces par Hewlett Packard Enterprise dépendent du type de service de garantie désigné pour votre produit.

<sup>3</sup>Non—Certaines pièces Hewlett Packard Enterprise ne sont pas conçues pour être remplacées par le client. Afin de se conformer aux exigences de la garantie la garantie du client, Hewlett Packard Enterprise demande à un fournisseur de services agréé de procéder au remplacement de la pièce. Ces pièces sont signalées par le mot « Non » dans le Catalogue de pièces illustré.

<sup>1</sup>Obbligatorio—Parti per le quali il cliente è tenuto a effettuare autonomamente la riparazione. Se si richiede l'intervento di Hewlett Packard Enterprise per la sostituzione di queste parti, al cliente verranno addebitate le spese di viaggio e manodopera dell'operazione.

<sup>2</sup>Facoltativo—Parti per le quali la riparazione in autonomia da parte del cliente è facoltativa. Queste parti sono progettate per consentire anche la riparazione da parte del cliente. Tuttavia, se il cliente richiede l'intervento di Hewlett Packard Enterprise per la sostituzione, potrebbero essere addebitate spese aggiuntive a seconda del tipo di garanzia in assistenza previsto per il prodotto.

<sup>3</sup>No—Alcune parti Hewlett Packard Enterprise non sono progettate la riparazione in autonomia da parte del cliente. In base a quanto previsto dalla garanzia per il cliente, Hewlett Packard Enterprise richiede l'intervento di un tecnico autorizzato per la sostituzione della parte. Queste parti sono contrassegnate con "No" nel catalogo parti illustrato.

<sup>1</sup>Zwingend—Teile, für die das Customer Self Repair-Verfahren zwingend vorgegeben ist. Wenn Sie den Austausch dieser Teile von Hewlett Packard Enterprise vornehmen lassen, werden Ihnen die Anfahrt- und Arbeitskosten für diesen Service berechnet.

<sup>2</sup>Optional—Teile, für die das Customer Self Repair-Verfahren optional ist. Diese Teile sind auch für Customer Self Repair ausgelegt. Wenn Sie jedoch den Austausch dieser Teile von Hewlett Packard Enterprise vornehmen lassen möchten, können bei diesem Service je nach den für Ihr Produkt vorgesehenen Garantiebedingungen zusätzliche Kosten anfallen.

<sup>3</sup>Nein—Einige Hewlett Packard Enterprise Teile sind nicht für Customer Self Repair ausgelegt. Um den Garantieanspruch des Kunden zu erfüllen, muss das Teil von einem Hewlett Packard Enterprise Servicepartner ersetzt werden. Im illustrierten Teilekatalog sind diese Teile mit „No“ bzw. „Nein“ gekennzeichnet.

<sup>1</sup>Obligatorio—Componentes cuya reparación por parte del usuario es obligatoria. Si solicita a Hewlett Packard Enterprise que realice la sustitución de estos componentes, tendrá que hacerse cargo de los gastos de desplazamiento y de mano de obra de dicho servicio.

<sup>2</sup>Opcional—Componentes cuya reparación por parte del usuario es opcional. Estos componentes también están diseñados para que puedan ser reparados por el usuario. Sin embargo, si precisa que Hewlett Packard Enterprise realice su sustitución, puede o no conllevar costes adicionales, dependiendo del tipo de servicio de garantía correspondiente al producto.

<sup>3</sup>No—Algunos componentes de Hewlett Packard Enterprise no están diseñados para que puedan ser reparados por el usuario. Para que el usuario haga valer su garantía, Hewlett Packard Enterprise pone como condición que un proveedor de servicios autorizado realice la sustitución de estos componentes. Dichos componentes se identifican con la palabra "No" en el catálogo ilustrado de componentes.

<sup>1</sup>Verplicht—Onderdelen die de klant zelf moet vervangen. Als u Hewlett Packard Enterprise vraagt deze onderdelen te vervangen, worden er reis- en arbeidskosten voor deze service in rekening gebracht.

<sup>2</sup>Optioneel—Onderdelen die de klant zelf kan vervangen. Deze onderdelen zijn ook ontworpen om door de klant zelf te worden vervangen. Als u Hewlett Packard Enterprise verzoekt om deze te vervangen, kan het zijn dat hiervoor extra kosten in rekening worden gebracht, afhankelijk van het soort garantie dat op uw product van toepassing is.

<sup>3</sup>Geen—Sommige onderdelen van Hewlett Packard Enterprise zijn niet ontworpen om door de klant zelf te worden vervangen. Om te voldoen aan de garantievoorwaarden eist Hewlett Packard Enterprise dat een geautoriseerde serviceverlener het onderdeel vervangt. Deze onderdelen worden aangeduid met 'Geen' in de geïllustreerde onderdelencatalogus.

<sup>1</sup>Obrigatório—Peças cujo reparo feito pelo cliente é obrigatório. Se desejar que a Hewlett Packard Enterprise substitua essas peças, serão cobradas as despesas de transporte e mão-de-obra do serviço.

<sup>2</sup>Opcional—Peças cujo reparo feito pelo cliente é opcional. Essas peças também são projetadas para o reparo feito pelo cliente. No entanto, se desejar que a Hewlett Packard Enterprise as substitua, pode haver ou não a cobrança de taxa adicional, dependendo do tipo de serviço de garantia destinado ao produto.

<sup>3</sup>Não—Algumas peças da Hewlett Packard Enterprise não são projetadas para o reparo feito pelo cliente. A fim de cumprir a garantia do cliente, a Hewlett Packard Enterprise exige que um técnico autorizado substitua a peça. Essas peças estão identificadas com a marca "No" (Não), no catálogo de peças ilustrado.

<sup>1</sup>Mandatory : 必須 — カスタマーセルフリペアが必須の部品。当該部品について、もしもお客様がHewlett Packard Enterpriseに交換作業を依頼される場合には、その修理サービスに関する交通費および人件費がお客様に請求されます。

<sup>2</sup>Optional : 任意 — カスタマーセルフリペアが任意である部品。この部品もカスタマーセルフリペア用です。当該部品について、もしもお客様がHewlett Packard Enterpriseに交換作業を依頼される場合には、お買い上げの製品に適用される保証サービス内容の範囲内においては、別途費用を負担していただくことなく保証サービスを受けることができます。

<sup>3</sup>No : 除外 — Hewlett Packard Enterprise製品の一部の部品は、カスタマーセルフリペアの対象外です。製品の保証を継続するためには、Hewlett Packard EnterpriseまたはHewlett Packard Enterprise正規保守代理店による交換作業が必須となります。部品カタログには、当該部品がカスタマーセルフリペア除外品である旨が記載されています。

<sup>1</sup>Mandatory — 客户必须自行维修的部件。如果您请求 Hewlett Packard Enterprise 更换这些部件，则必须为该服务支付差旅费和人工费用。

<sup>2</sup>Optional — 客户可以选择是否自行维修的部件。这些部件也是为客户自行维修设计的。不过，如果您要求 Hewlett Packard Enterprise 为您更换这些部件，则根据为您的产品指定的保修服务类型，Hewlett Packard Enterprise 可能收取或不再收取任何附加费用。

<sup>3</sup>No — 某些 Hewlett Packard Enterprise 部件的设计并未考虑客户自行维修。为了满足客户保修的需要，Hewlett Packard Enterprise 要求授权服务提供商更换相关部件。这些部件在部件图解目录中标记为“否”。

<sup>1</sup>Mandatory — 客戶自行維修所使用的零件是強制性的。如果您要求 Hewlett Packard Enterprise 更換這些零件，Hewlett Packard Enterprise 將會向您收取此服務所需的外出費用與勞動成本。

<sup>2</sup>Optional — 客戶自行維修所使用的零件是選購的。這些零件也設計用於客戶自行維修之用。不過，如果您要求 Hewlett Packard Enterprise 為您更換，則可能需要也可能不需要負擔額外的費用，端視針對此產品指定的保固服務類型而定。

<sup>3</sup>No — 某些 Hewlett Packard Enterprise 零件沒有消費者可自行維修的設計。為符合客戶保固，Hewlett Packard Enterprise 需要授權的服務供應商更換零件。這些零件在圖示的零件目錄中，被標示為「否」。

<sup>1</sup>Mandatory — 고객 셀프 수리가 의무 사항인 필수 부품. 사용자가 Hewlett Packard Enterprise에 이 부품의 교체를 요청할 경우 해당 서비스에 대한 출장비 및 작업비가 청구됩니다.

<sup>2</sup>Optional — 고객 셀프 수리가 선택 사항인 부품. 이러한 부품들도 고객 셀프 수리가 가능하도록 설계되었습니다. 하지만 사용자가 Hewlett Packard Enterprise에 이러한 부품의 교체를 요청할 경우 사용자가 구입한 제품에 해당하는 보증 서비스 유형에 따라 추가 비용 없이 교체가 가능할 수 있습니다.

<sup>3</sup>No — 일부 Hewlett Packard Enterprise 부품은 고객 셀프 수리가 불가능하도록 설계되었습니다. Hewlett Packard Enterprise는 만족스러운 고객 보증을 위해 공인 서비스 제공업체를 통해 부품을 교체하도록 요구하고 있습니다. 이러한 부품들은 Illustrated Parts Catalog에 "No"라고 표시되어 있습니다.



# Removal and replacement procedures

## Required tools

You need the following items for some procedures:

- T-10 Torx screwdriver
- T-15 Torx screwdriver
- HPE Insight Diagnostics (on page 55)

## Safety considerations

Before performing service procedures, review all the safety information.

## Preventing electrostatic discharge

To prevent damaging the system, be aware of the precautions you need to follow when setting up the system or handling parts. A discharge of static electricity from a finger or other conductor may damage system boards or other static-sensitive devices. This type of damage may reduce the life expectancy of the device.

To prevent electrostatic damage:

- Avoid hand contact by transporting and storing products in static-safe containers.
- Keep electrostatic-sensitive parts in their containers until they arrive at static-free workstations.
- Place parts on a grounded surface before removing them from their containers.
- Avoid touching pins, leads, or circuitry.
- Always be properly grounded when touching a static-sensitive component or assembly.

## Symbols on equipment

The following symbols may be placed on equipment to indicate the presence of potentially hazardous conditions.



This symbol indicates the presence of hazardous energy circuits or electric shock hazards. Refer all servicing to qualified personnel.

**WARNING:** To reduce the risk of injury from electric shock hazards, do not open this enclosure. Refer all maintenance, upgrades, and servicing to qualified personnel.



This symbol indicates the presence of electric shock hazards. The area contains no user or field serviceable parts. Do not open for any reason.

**WARNING:** To reduce the risk of injury from electric shock hazards, do not open this enclosure.



This symbol on an RJ-45 receptacle indicates a network interface connection.

**WARNING:** To reduce the risk of electric shock, fire, or damage to the equipment, do not plug telephone or telecommunications connectors into this receptacle.



This symbol indicates the presence of a hot surface or hot component. If this surface is contacted, the potential for injury exists.

**WARNING:** To reduce the risk of injury from a hot component, allow the surface to cool before touching.



6.80 kg  
10.00 lb

This symbol indicates that the component exceeds the recommended weight for one individual to handle safely.

**WARNING:** To reduce the risk of personal injury or damage to the equipment, observe local occupational health and safety requirements and guidelines for manual material handling.



These symbols, on power supplies or systems, indicate that the equipment is supplied by multiple sources of power.

**WARNING:** To reduce the risk of injury from electric shock, remove all power cords to completely disconnect power from the system.

## System warnings and cautions

Before installing a server, be sure that you understand the following warnings and cautions.



**WARNING:** To reduce the risk of electric shock or damage to the equipment:

- Do not disable the power cord grounding plug. The grounding plug is an important safety feature.
- Plug the power cord into a grounded (earthed) electrical outlet that is easily accessible at all times.
- Unplug the power cord from the power supply to disconnect power to the equipment.
- Do not route the power cord where it can be walked on or pinched by items placed against it. Pay particular attention to the plug, electrical outlet, and the point where the cord extends from the server.



**WARNING:** To reduce the risk of personal injury from hot surfaces, allow the drives and the internal system components to cool before touching them.



**CAUTION:** Do not operate the server for long periods with the access panel open or removed. Operating the server in this manner results in improper airflow and improper cooling that can lead to thermal damage.

## Preparation procedures

To access some components and perform certain service procedures, you must perform one or more of the following procedures:

- Power down the server (on page [26](#)).
- Remove the server (on page [27](#)).
- Remove the I/O module (on page [28](#)).
- Install the server (on page [29](#)).

## Power down the server

Before powering down the server for any upgrade or maintenance procedures, perform a backup of critical server data and programs.



---

**IMPORTANT:** When the server is in standby mode, auxiliary power is still being provided to the system.

---

To power down the server, use one of the following methods:

- Press and release the Power On/Standby button.  
This method initiates a controlled shutdown of applications and the OS before the server enters standby mode.
- Press and hold the Power On/Standby button for more than 4 seconds to force the server to enter standby mode.  
This method forces the server to enter standby mode without properly exiting applications and the OS. If an application stops responding, you can use this method to force a shutdown.
- Use a virtual power button selection through iLO 4.  
This method initiates a controlled remote shutdown of applications and the OS before the server enters standby mode.

Before proceeding, verify the server is in standby mode by observing that the system power LED is amber.

## Remove the server



---

**CAUTION:** To prevent improper cooling and thermal damage, operate servers only when the open side of the server is enclosed by either another server, a divider, or the chassis wall.

---



---

**IMPORTANT:** When removing a server from an even numbered bay that remains unoccupied by another server for an extended period of time, the performance of the server installed in the bay to the immediate left may be impacted.

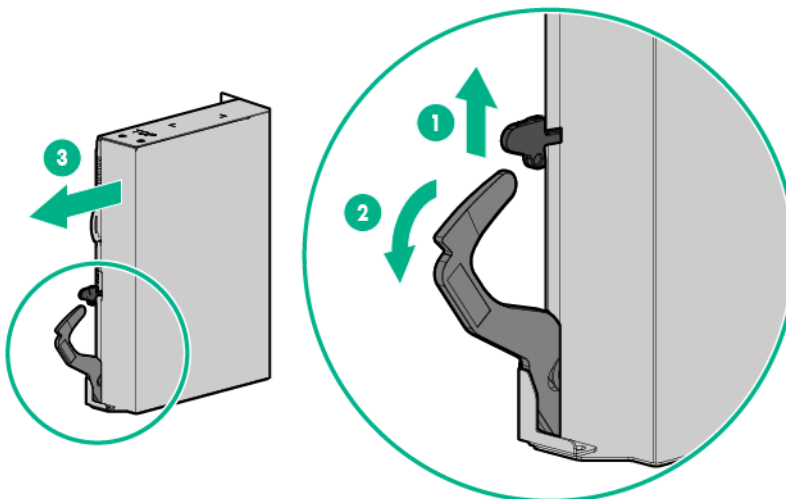

---

1. Power down the server (on page 26).
2. Disconnect all peripheral cables from the server.
3. Remove the server. If removing a server from an even-numbered bay, then do one of the following:
  - Power down the associated odd-numbered server until the even-numbered server is installed ("[Power down the server](#)" on page 26).
  - Install the service tray in the even-numbered bay until the server can be reinstalled ("[Install the service tray](#)" on page 28).



4. Place the server on a flat, level work surface.

## Install the service tray

-  **CAUTION:** To prevent improper cooling and thermal damage, operate servers only when the open side of the server is enclosed by either another server, a divider, or the chassis wall.
-  **CAUTION:** To prevent improper cooling and thermal damage, do not operate the chassis unless all bays are populated with a component or a blank.
-  **IMPORTANT:** To maintain proper airflow for odd-numbered servers, use the service tray during even-numbered server servicing events only. This tray is not intended for use during normal server operation.

Install the component as indicated.

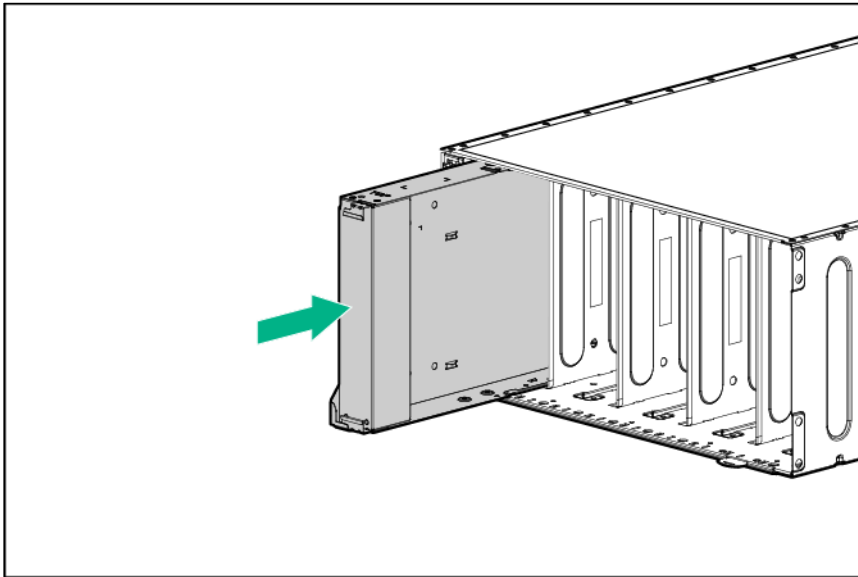

## Remove the I/O module

1. Power down the server associated with the I/O module ("[Power down the server](#)" on page 26).
2. Remove the server associated with the I/O module ("[Remove the server](#)" on page 27).

3. Remove the I/O module.

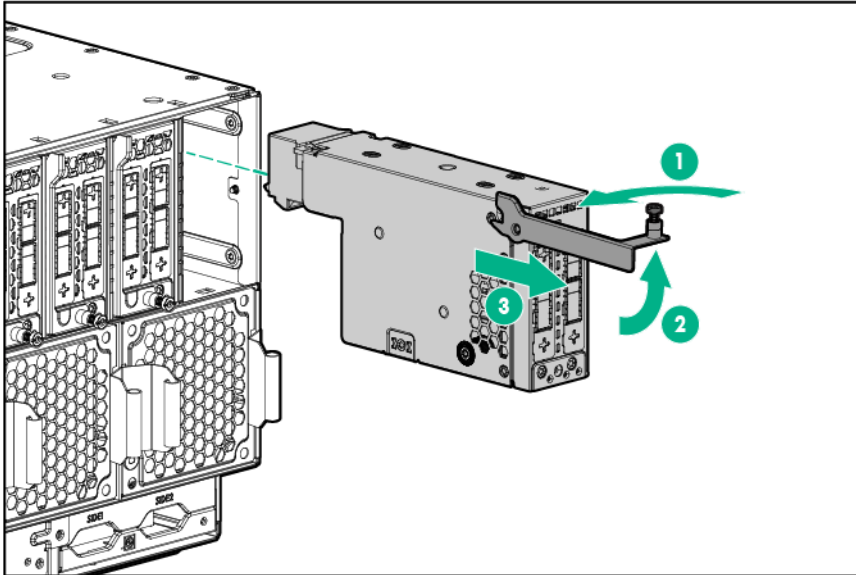

## Install the server

**CAUTION:** To prevent improper cooling and thermal damage, operate servers only when the open side of the server is enclosed by either another server, a divider, or the chassis wall.

When installing servers in the chassis, observe the following guidelines to ensure proper air flow:

- Always populate the enclosure from right to left, beginning with bay 10.
- Operate servers only when the open side of the server is enclosed by either another server, a divider, or the chassis wall.

To install the component:

1. Prepare the server for installation.

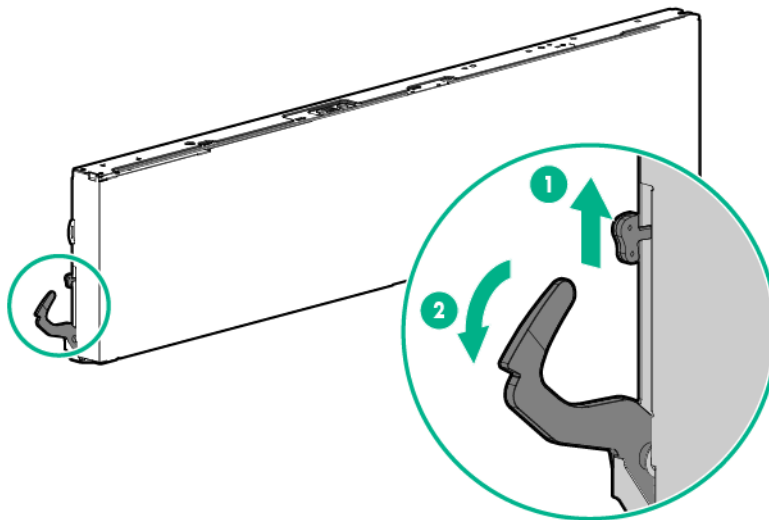

2. Install the server. When seated properly, the server will be flush with the front of the chassis and the release lever will close completely without resistance.

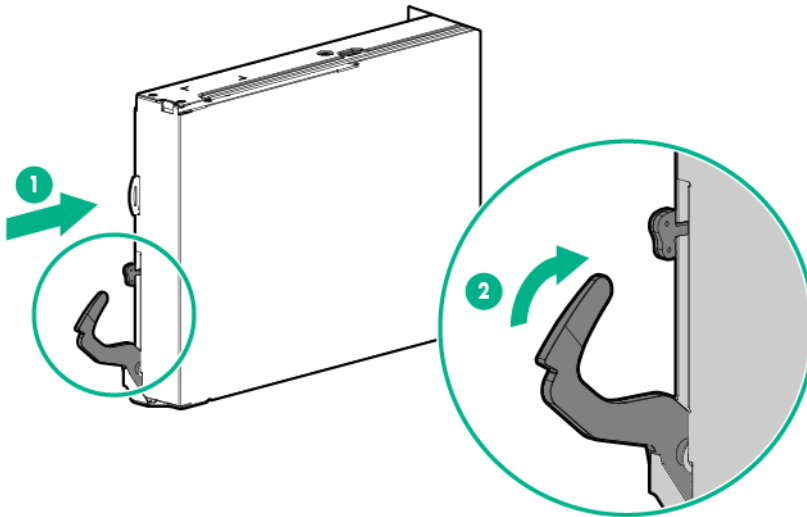

3. Press the Power On/Standby button.  
The server exits standby mode and applies full power to the system. The system power LED changes from amber to green.

## Removing and replacing a drive

To remove the component:

1. Determine the status of the drive from the drive LED definitions ("[Hot-plug drive LED definitions](#)" on page 64).
2. Back up all data on the drive.
3. Remove the drive.

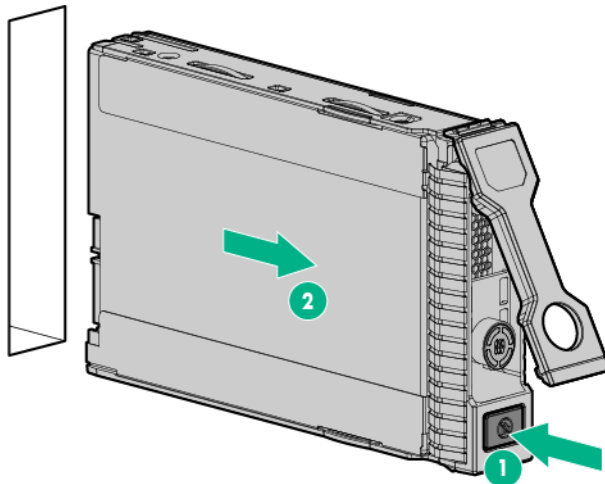

To replace the drive, slide the drive into the bay until it is fully seated, and then close the latch handle to lock the drive in the bay.

# PCIe/FlexibleLOM I/O module

To remove the component:

1. Power down the server associated with the I/O module ("Power down the server" on page 26).
2. Remove the server associated with the I/O module ("Remove the server" on page 27).
3. Remove the PCIe/FlexibleLOM I/O module.

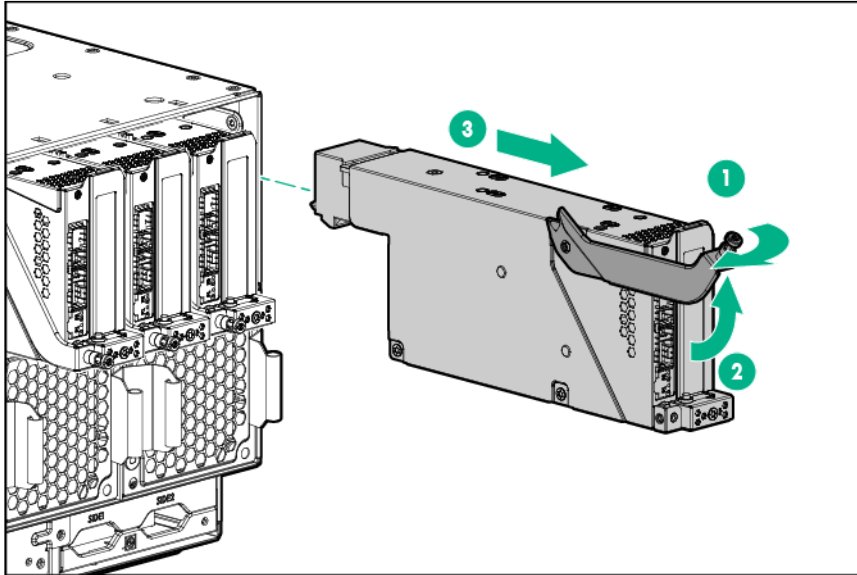

To replace the component, reverse the removal procedure.

# PCIe/FlexibleLOM I/O module PCIe options

To remove the component:

1. Power down the server associated with the I/O module ("Power down the server" on page 26).
2. Remove the server associated with the I/O module ("Remove the server" on page 27).
3. Remove the PCIe/FlexibleLOM I/O module.
4. Remove the cover from the PCIe/FlexibleLOM I/O module.

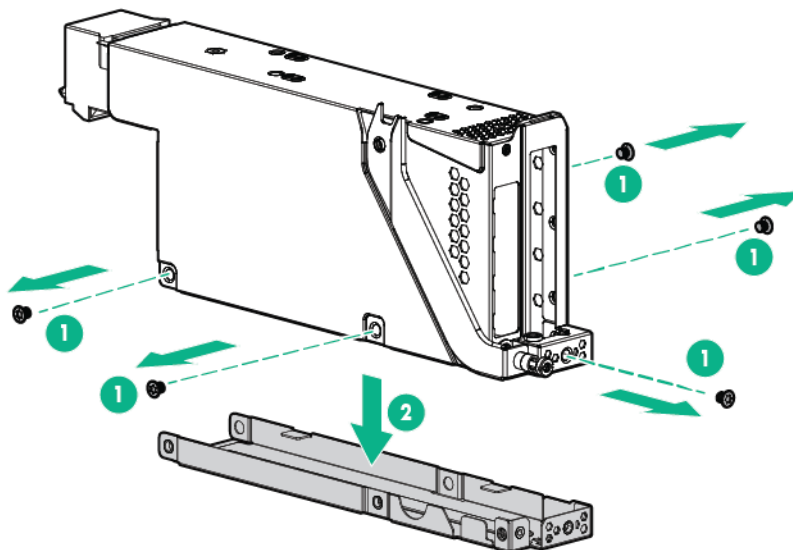

5. Remove the PCIe/FlexLOM I/O module expansion board.

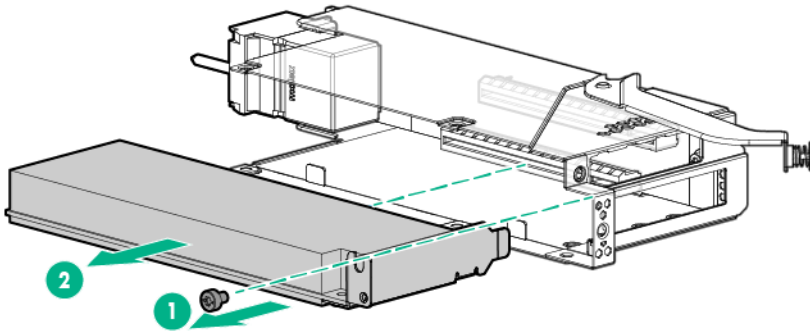

To replace the component, reverse the removal procedure.

## PCIe/FlexibleLOM I/O module FlexibleLOM options

To remove the component:

1. Power down the server associated with the I/O module ("[Power down the server](#)" on page 26).
2. Remove the server associated with the I/O module ("[Remove the server](#)" on page 27).
3. Remove the PCIe/FlexibleLOM I/O module.
4. Remove the cover from the PCIe/FlexibleLOM I/O module.

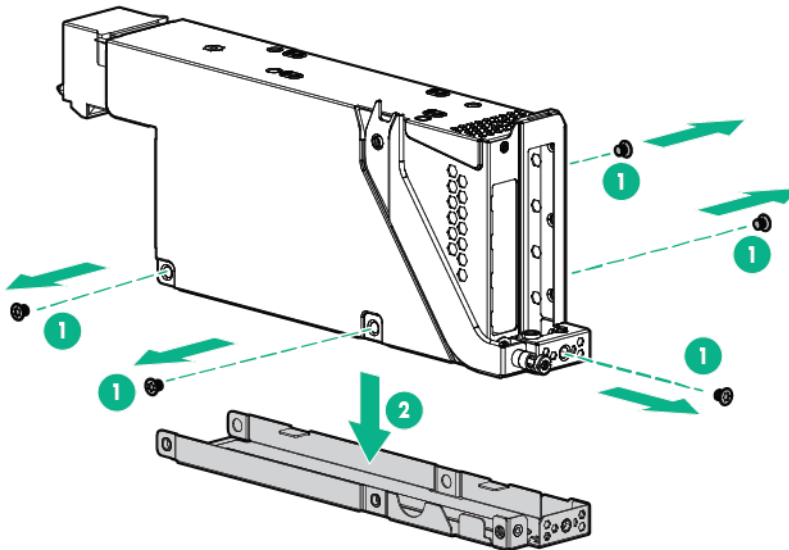



5. Remove the FlexibleLOM adapter from the FlexibleLOM slot on the PCIe/FlexibleLOM riser.

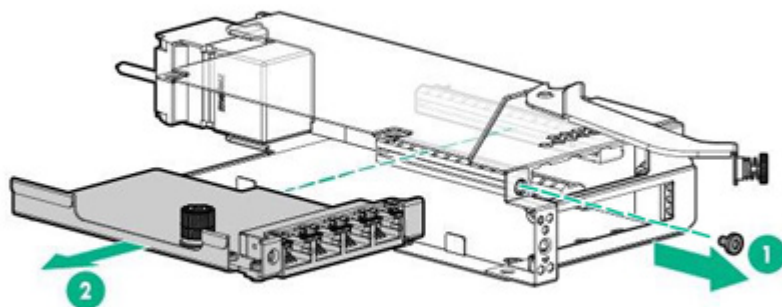

To replace the component, reverse the removal procedure.

## Dual FlexibleLOM riser options

To remove the component:

1. Power down the server associated with the I/O module ("[Power down the server](#)" on page 26).
2. Remove the server associated with the I/O module ("[Remove the server](#)" on page 27).
3. Remove the I/O module (on page 28).
4. Using a T-10 Torx screwdriver, remove the I/O module FlexibleLOM adapter.

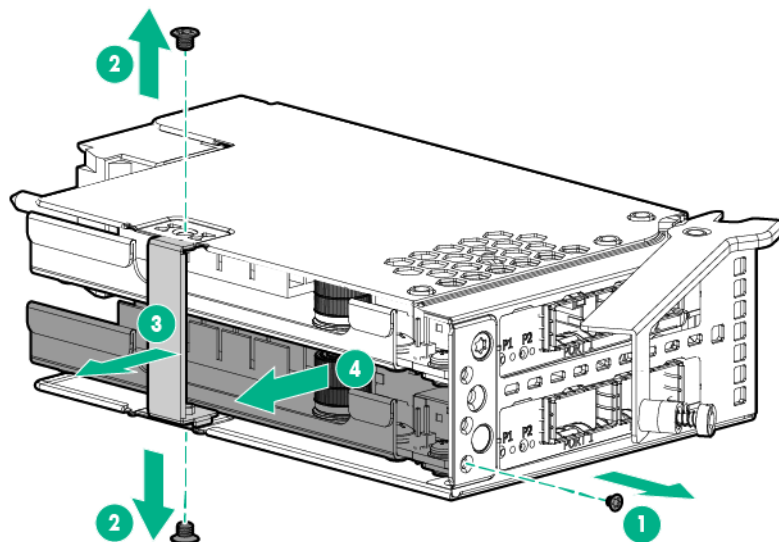

To replace the component, reverse the removal procedure.

# Processor air baffle

To remove the component:

1. Power down the server (on page 26).
2. Disconnect all peripheral cables from the server.
3. Remove the server (on page 27).
4. Place the server on a flat, level work surface.
5. Remove the processor air baffle.

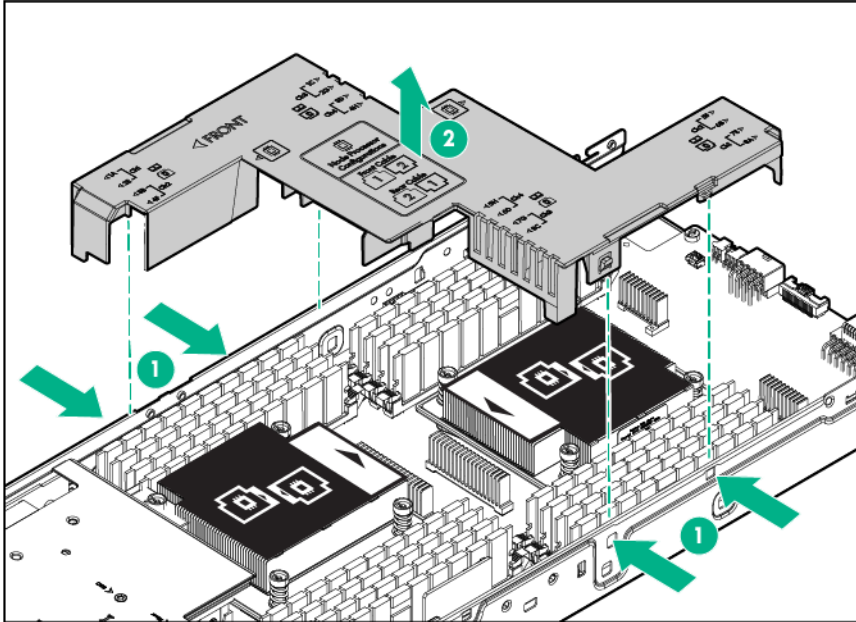

To replace the component, reverse the removal procedure.

# DIMMs

To remove the component:

1. Power down the server (on page 26).
2. Disconnect all peripheral cables from the server.
3. Remove the server (on page 27).
4. Place the server on a flat, level work surface.
5. Remove the processor air baffle ("Processor air baffle" on page 34).

6. Remove the DIMM.

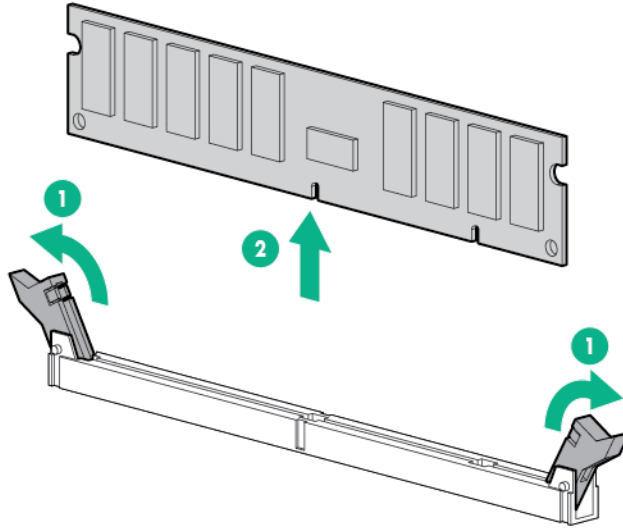

To replace the component, reverse the removal procedure.

## PCIe riser board assembly

To remove the component:

1. To replace the component, reverse the removal procedure. Power down the server (on page 26).
2. Disconnect all peripheral cables from the server.
3. Remove the server (on page 27).
4. Place the server on a flat, level work surface.
5. Remove the PCIe riser board assembly.

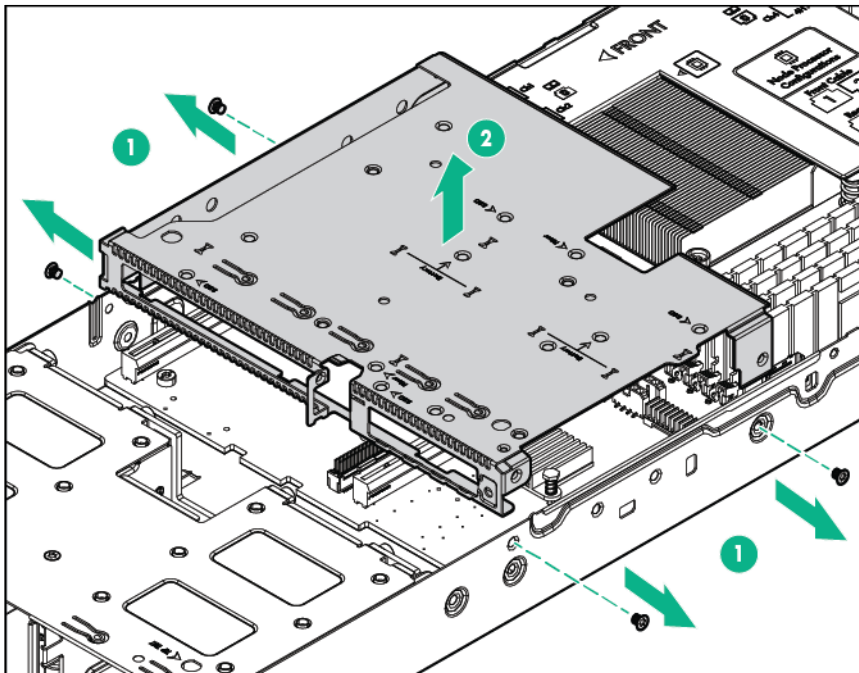

6. Disconnect all cables connected to existing expansion boards.

# PCIe expansion board options

The server supports installation of options in the PCIe riser board assembly. For more information about supported options, see the product QuickSpecs on the Hewlett Packard Enterprise website (<http://www.hpe.com/info/gs>).

Some expansion board options may ship with a plastic baffle or scoop installed on the board. Always remove this baffle before attempting to install either option on this server.



**IMPORTANT:** Remove the baffle or scoop from the controller before installing the controller in the PCIe riser board assembly.

To remove the component:

1. Power down the server (on page 26).
2. Disconnect all peripheral cables from the server.
3. Remove the server (on page 27).
4. Place the server on a flat, level work surface.
5. Remove the PCI riser board assembly ("PCIe riser board assembly" on page 35).
6. Disconnect all cables connected to existing expansion boards.
7. Using a T-15 Torx screwdriver, remove the PCIe expansion board option installed on the PCI riser board assembly.

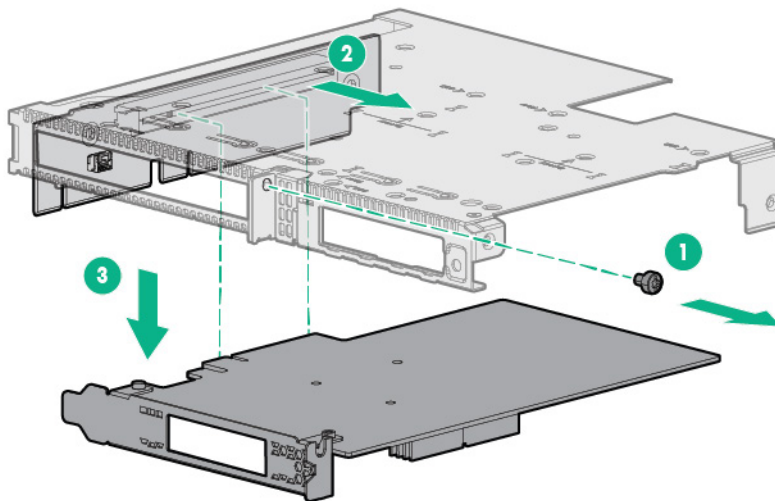

To replace the component, reverse the removal procedure.

## Cache module

To remove the component:

1. Power down the server (on page 26).
2. Disconnect all peripheral cables from the server.
3. Remove the server (on page 27).
4. Place the server on a flat, level work surface.
5. Remove the PCIe riser board assembly ("PCIe riser board assembly" on page 35).
6. Remove the PCIe expansion board ("PCIe expansion board options" on page 36).

7. Disconnect the cable from the cache module.
8. Remove the cache module from the controller.

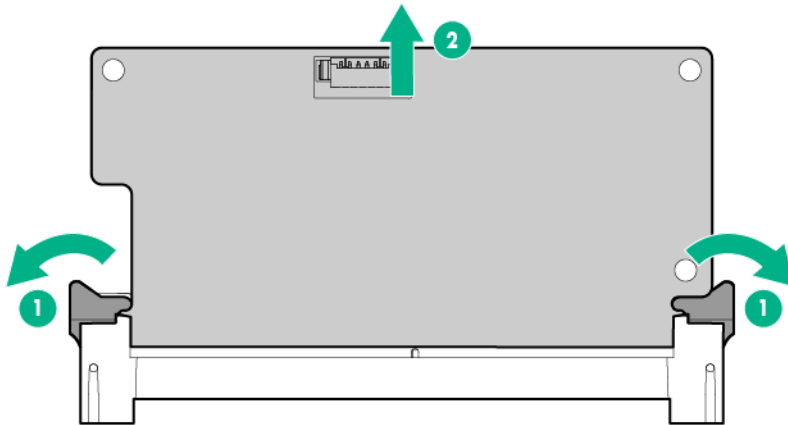

To replace the component, reverse the removal procedure.

## HPE Smart Storage Battery option

To install the component:

1. Power down the server (on page 26).
2. Disconnect all peripheral cables from the server.
3. Remove the server (on page 27).
4. Place the server on a flat, level work surface.
5. Remove the PCIe riser board assembly ("[PCIe riser board assembly](#)" on page 35).
6. Install the cache module on the controller, if necessary ("[Cache module](#)" on page 36).
7. Install the storage controller ("[PCIe expansion board options](#)" on page 36).
8. Using a T-10 Torx screwdriver, install the HPE Smart Storage Battery.

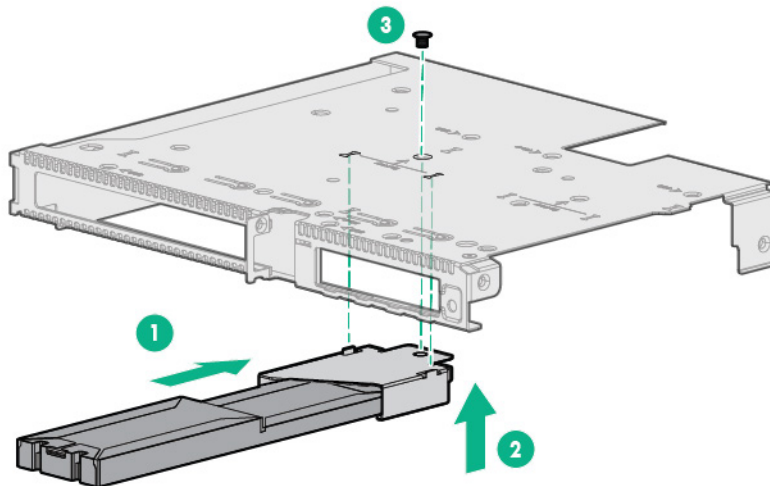

9. Install the PCIe riser board assembly ("[PCIe riser board assembly](#)" on page 35).



**IMPORTANT:** The server does not power up if the PCI riser cage is not seated properly.

10. Connect and route all drive cables. For more information, see "Drive cabling (on page 67)."
11. Install the server into the chassis ("Install the server" on page 29).
12. Connect all peripheral cables to the server.
13. Press the Power On/Standby button.

The server exits standby mode and applies full power to the system. The system power LED changes from amber to green.

## Hot-plug drive cage assembly

To remove the component:

1. Back up all server data on the drive.
2. Power down the server (on page 26).
3. Disconnect all peripheral cables from the server.
4. Remove the server (on page 27).
5. Place the server on a flat, level work surface.
6. Remove the PCIe riser board assembly ("PCIe riser board assembly" on page 35).
7. Disconnect all cables from the drive cage backplane.
  - o 12 GB backplane

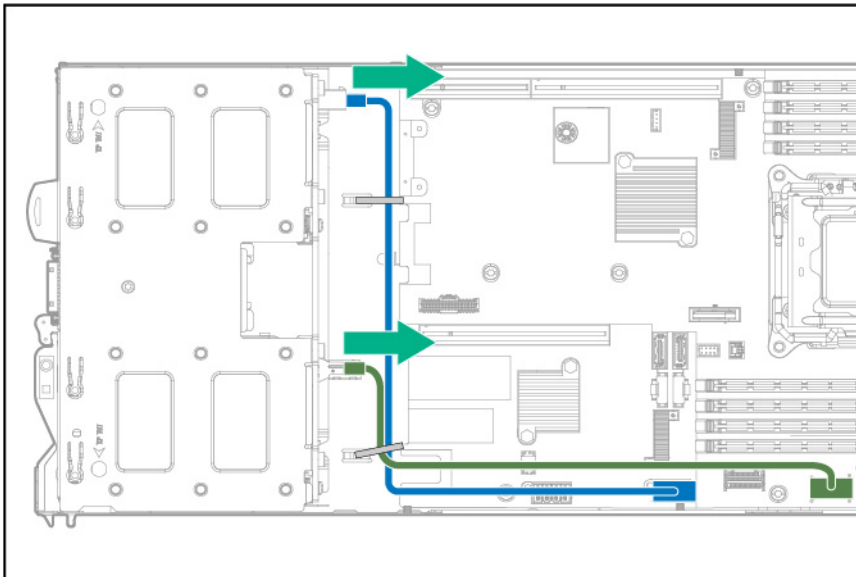

- o 6 GB backplanes (one for each drive box)

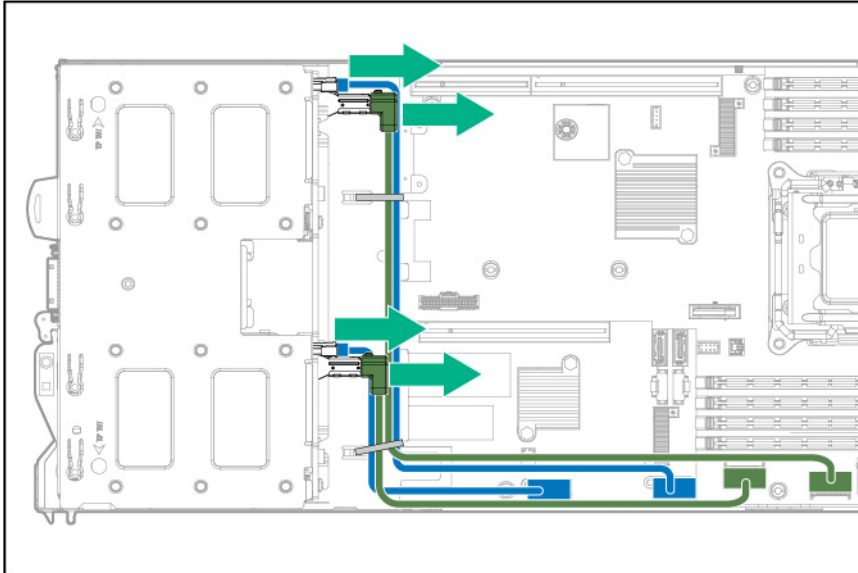

8. Disconnect the front panel LED board assembly cables.

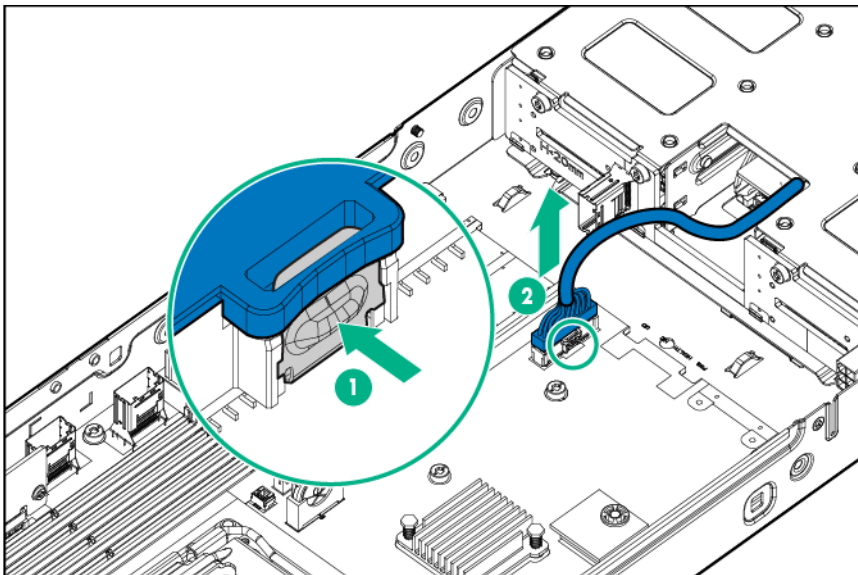

9. Remove all drives ("[Removing and replacing a drive](#)" on page 30).

10. Remove the drive cage assembly.

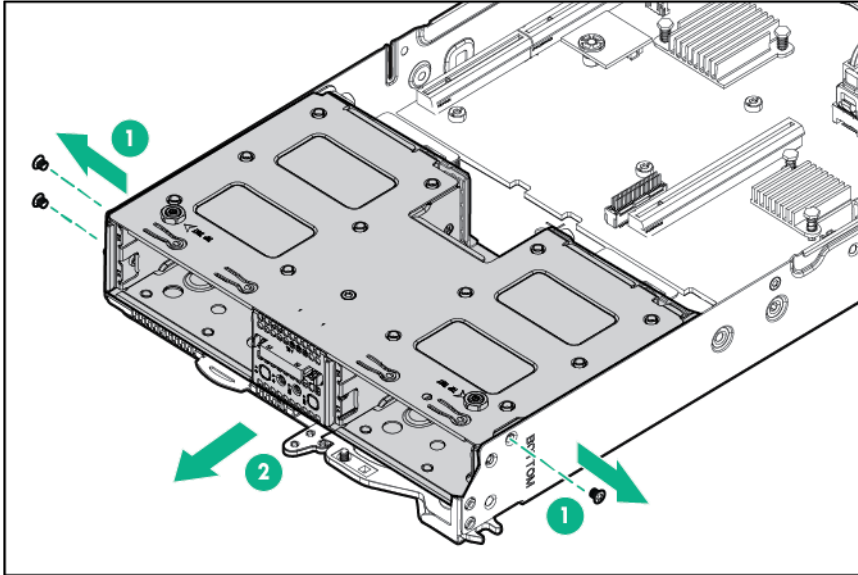

To replace the component, reverse the removal procedure.

## Front panel LED board assembly

To remove the component:

1. Back up all server data on the drive.
2. Power down the server (on page 26).
3. Disconnect all peripheral cables from the server.
4. Remove the server (on page 27).
5. Place the server on a flat, level work surface.
6. Remove the PCI riser board assembly ("PCI riser board assembly" on page 35).
7. Disconnect the front panel LED board assembly cables.

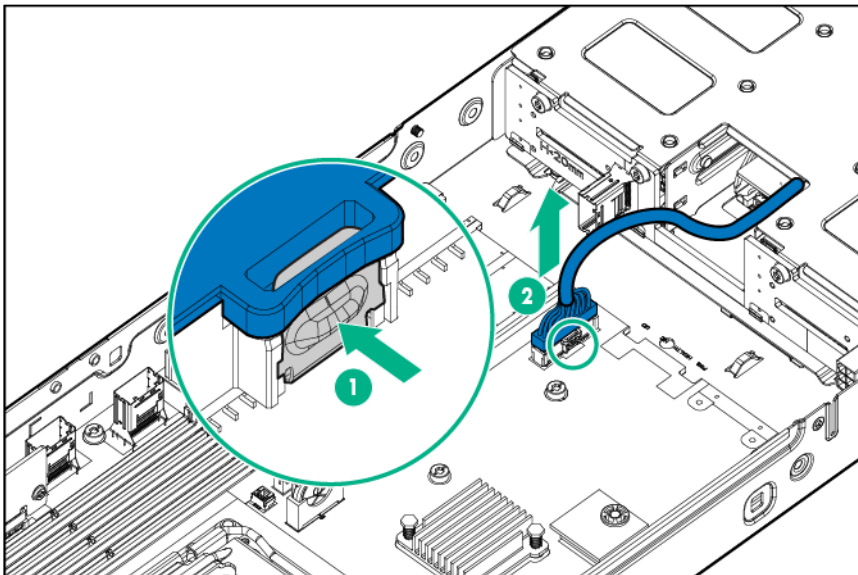



8. Remove the front panel LED board assembly.

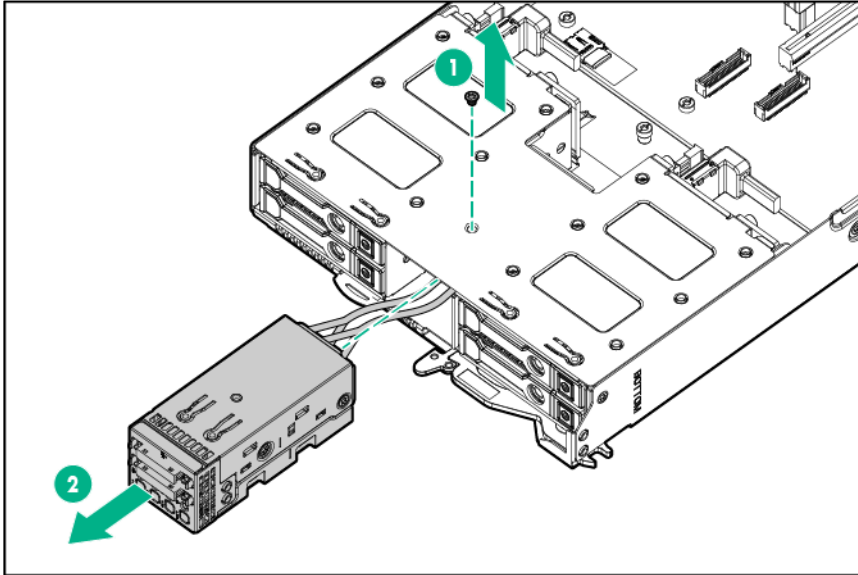

To replace the component, reverse the removal procedure.

## System battery

If the server no longer automatically displays the correct date and time, then replace the battery that provides power to the real-time clock. Under normal use, battery life is 5 to 10 years.



**WARNING:** The computer contains an internal lithium manganese dioxide, a vanadium pentoxide, or an alkaline battery pack. A risk of fire and burns exists if the battery pack is not properly handled. To reduce the risk of personal injury:

- Do not attempt to recharge the battery.
- Do not expose the battery to temperatures higher than 60°C (140°F).
- Do not disassemble, crush, puncture, short external contacts, or dispose of in fire or water.
- Replace only with the spare designated for this product.

To remove the component:

1. Power down the server (on page 26).
2. Disconnect all peripheral cables from the server.
3. Remove the server (on page 27).
4. Place the server on a flat, level work surface.
5. Locate the battery on the system board.

6. Remove the battery.

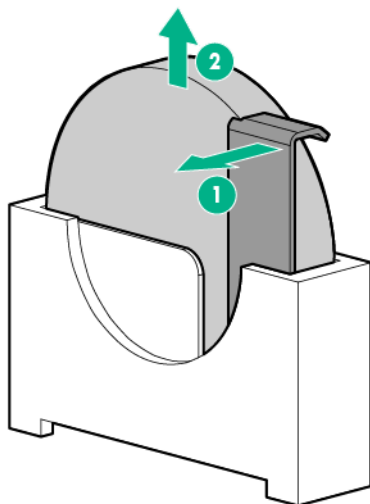

---

**IMPORTANT:** Replacing the system board battery resets the system ROM to its default configuration. After replacing the battery, reconfigure the system through RBSU.

---

To replace the component, reverse the removal procedure.

For more information about battery replacement or proper disposal, contact an authorized reseller or an authorized service provider.

## Heatsink



---

**WARNING:** To reduce the risk of personal injury from hot surfaces, allow the drives and the internal system components to cool before touching them.

---

To remove the component:

1. Power down the server (on page [26](#)).
2. Remove the server (on page [27](#)).

3. Remove the heatsink.

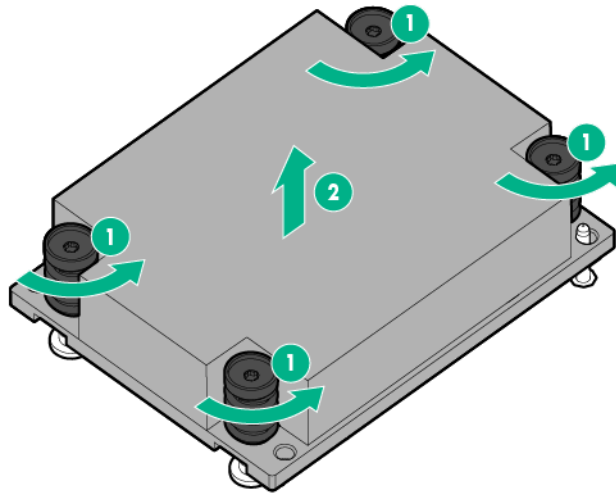

To replace the component:

1. Clean the old thermal grease from the processor with the alcohol swab. Allow the alcohol to evaporate before continuing.
2. Remove the thermal interface protective cover from the heatsink.

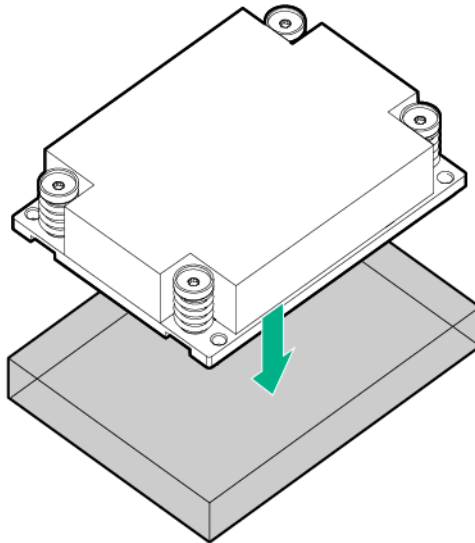

**CAUTION:** To avoid damage to the system board, processor socket, and screws, do not overtighten the heatsink screws. Use the wrench supplied with the system to reduce the possibility of overtightening the screws.

3. Align and install the heatsink. Alternate tightening the screws until the heatsink is seated properly.

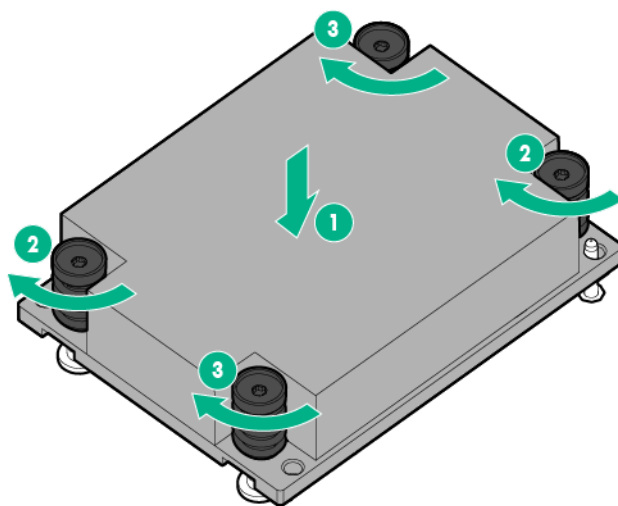

4. Install the processor air baffle ("Processor air baffle" on page 34).
5. Install the server (on page 29).

## Processor



**WARNING:** To reduce the risk of personal injury from hot surfaces, allow the drives and the internal system components to cool before touching them.



**CAUTION:** To prevent possible server overheating, always populate each processor socket with a processor socket cover and a heatsink blank or a processor and a heatsink.



**IMPORTANT:** Processor socket 1 must always be populated. If processor socket 1 is empty, the server does not power up.

---

To remove the component:

1. Update the system ROM.  
Locate and download the latest ROM version from the Hewlett Packard Enterprise website (<http://www.hpe.com/support>). Follow the instructions on the website to update the system ROM.
2. Power down the server (on page 26).
3. Disconnect all peripheral cables from the server.
4. Remove the server (on page 27).
5. Place the server on a flat, level work surface.
6. Remove the processor air baffle ("Processor air baffle" on page 34).
7. Remove the heatsink ("Heatsink" on page 42).

8. Open each of the processor locking levers in the order indicated, and then open the processor retaining bracket.

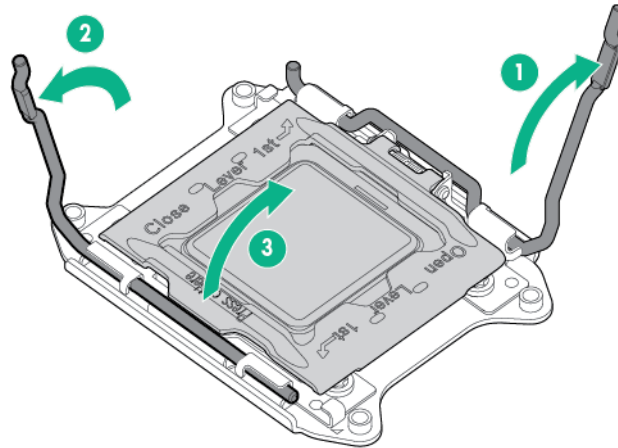

---

**CAUTION:** THE PINS ON THE SYSTEM BOARD ARE VERY FRAGILE AND EASILY DAMAGED. To avoid damage to the system board, do not touch the processor or the processor socket contacts.

---

9. Remove the processor from the processor retaining bracket.

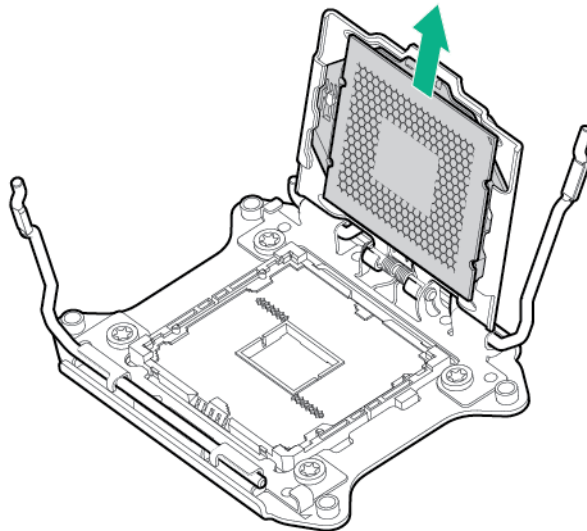

To replace the component:

---

**CAUTION:** To avoid damage to the system board, processor socket, and screws, do not overtighten the heatsink screws. Use the wrench supplied with the system to reduce the possibility of overtightening the screws.

---

1. Install the processor. Verify that the processor is fully seated in the processor retaining bracket by visually inspecting the processor installation guides on either side of the processor. **THE PINS ON THE SYSTEM BOARD ARE VERY FRAGILE AND EASILY DAMAGED.**

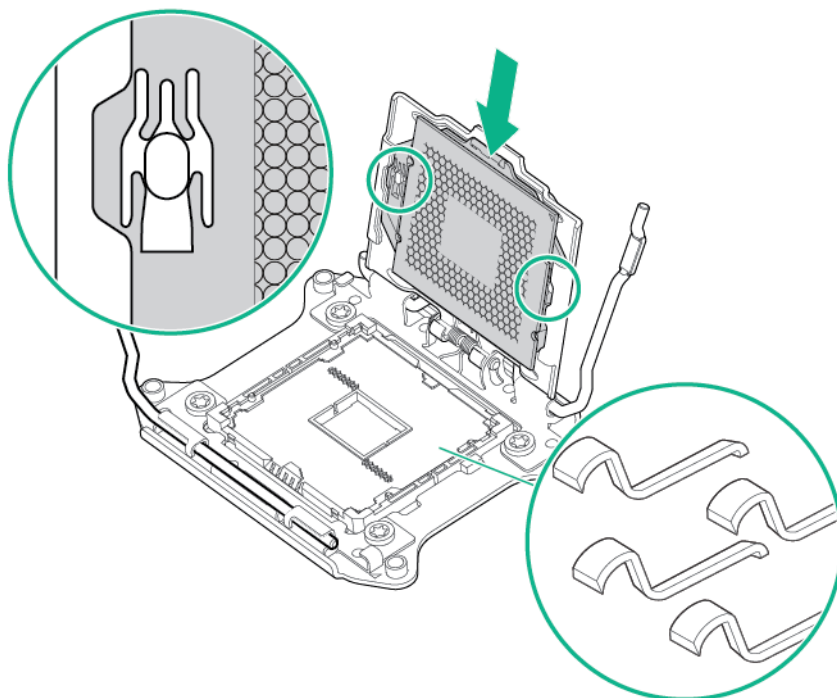

---

⚠ **CAUTION: THE PINS ON THE SYSTEM BOARD ARE VERY FRAGILE AND EASILY DAMAGED.** To avoid damage to the system board, do not touch the processor or the processor socket contacts.

---

⚠ **CAUTION:** Do not press down on the processor. Pressing down on the processor may cause damage to the processor socket and the system board. Press only in the area indicated on the processor retaining bracket.

---

2. Close the processor retaining bracket. When the processor is installed properly inside the processor retaining bracket, the processor retaining bracket clears the flange on the front of the socket.

3. Press and hold the processor retaining bracket in place, and then close each processor locking lever. Press only in the area indicated on the processor retaining bracket.

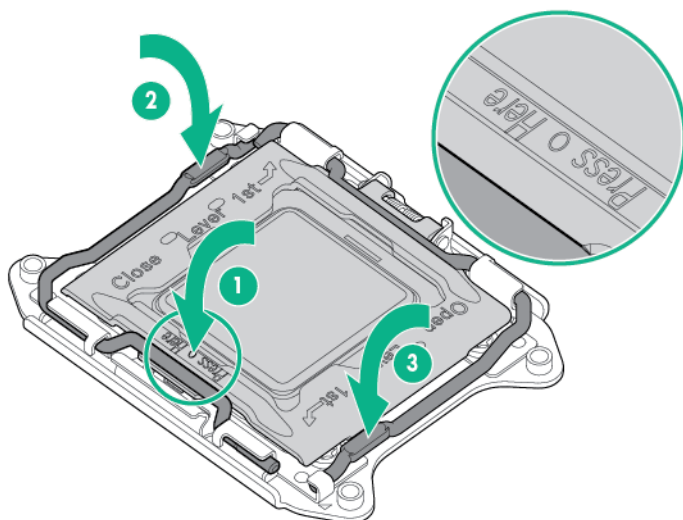

4. Align and install the heatsink. Alternate tightening the screws until the heatsink is seated properly.

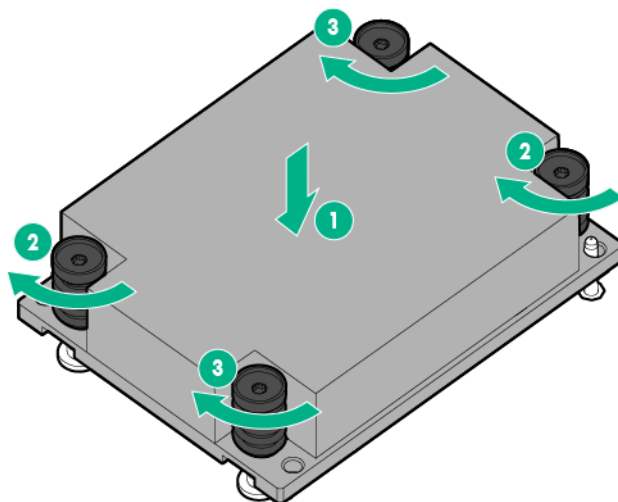

5. Install the processor air baffle ("Processor air baffle" on page 34).
6. Install the server (on page 29).

## System board

To remove the component:

1. Power down the server (on page 26).
2. Disconnect all peripheral cables from the server.
3. Remove the server (on page 27).
4. Place the server on a flat, level work surface.
5. Remove the PCI riser board assembly ("PCIe riser board assembly" on page 35).
6. Disconnect cables to the drive backplane, if installed ("Drive cabling" on page 67).

7. Disconnect the front panel LED board assembly cables from the system board ("Front panel LED board assembly cabling" on page 71).
8. Remove the processor air baffle ("Processor air baffle" on page 34).
9. Remove all DIMMs ("DIMMs" on page 34).
10. Remove all heatsinks ("Heatsink" on page 42).
11. Remove all processors ("Processor" on page 44).
12. Disconnect all cables from the system board.
13. Remove the failed system board.

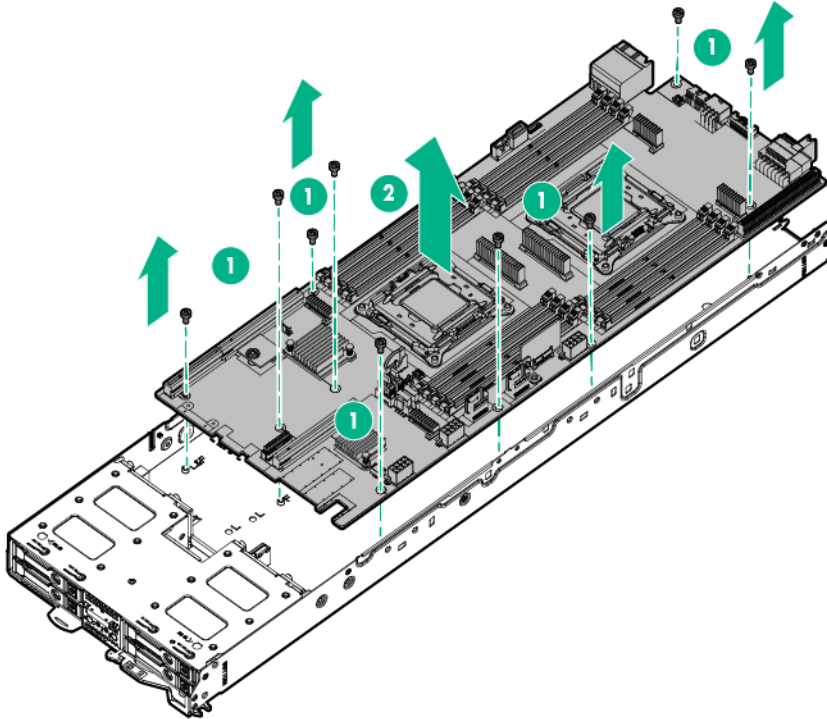



To replace the system board:

1. Install the system board.

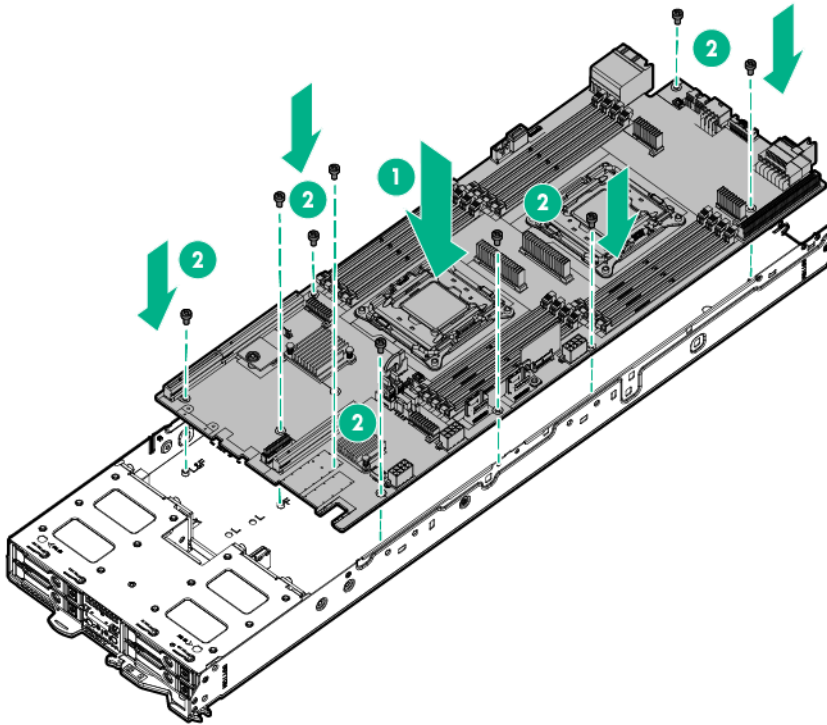

2. Connect all cables disconnected from the failed system board.
3. Connect cables to the drive backplane, if installed ("[Drive cabling](#)" on page 67).
4. Install all processors ("[Processor](#)" on page 44).
5. Install all heatsinks ("[Heatsink](#)" on page 42).
6. Install all DIMMs ("[DIMMs](#)" on page 34).
7. Install the processor air baffle ("[Processor air baffle](#)" on page 34).
8. Install the PCI riser board assembly.
9. Install the server into the chassis ("[Install the server](#)" on page 29).
10. Connect the peripheral cables.
11. Press the Power On/Standby button.

The server exits standby mode and applies full power to the system. The system power LED changes from amber to green.

## Re-entering the server serial number and product ID



**IMPORTANT:** When re-entering the serial number, be sure to use the server serial number. This number is located on the front panel serial number/iLO information pull tab. Do not use the chassis serial number.

After you replace the system board, you must re-enter the server serial number and the product ID.

1. During the server startup sequence, press the **F9** key to access RBSU.
2. Select the **Advanced Options** menu.
3. Select **Service Options**.
4. Select **Serial Number**. The following warning appears:

Warning: The serial number should ONLY be modified by qualified service personnel. This value should always match the serial number located on the chassis.

5. Press the **Enter** key to clear the warning.
6. Enter the serial number and press the **Enter** key.
7. Select **Product ID**. The following warning appears:  
Warning: The Product ID should ONLY be modified by qualified service personnel. This value should always match the Product ID located on the chassis.
8. Enter the product ID and press the **Enter** key.
9. Press the **Esc** key to close the menu.
10. Press the **Esc** key to exit RBSU.
11. Press the **F10** key to confirm exiting RBSU. The server automatically reboots.

## HP Trusted Platform Module

The TPM is not a customer-removable part.



---

**CAUTION:** Any attempt to remove an installed TPM from the system board breaks or disfigures the TPM security rivet. Upon locating a broken or disfigured rivet on an installed TPM, administrators should consider the system compromised and take appropriate measures to ensure the integrity of the system data.

---

If you suspect a TPM board failure, leave the TPM installed and remove the system board. Contact a Hewlett Packard Enterprise authorized service provider for a replacement system board and TPM board.

# Troubleshooting

## Troubleshooting resources

The *HPE ProLiant Gen9 Troubleshooting Guide, Volume I: Troubleshooting* provides procedures for resolving common problems and comprehensive courses of action for fault isolation and identification, issue resolution, and software maintenance on ProLiant servers and server blades. To view the guide, select a language:

- English ([http://www.hpe.com/support/Gen9\\_TSG\\_en](http://www.hpe.com/support/Gen9_TSG_en))
- French ([http://www.hpe.com/support/Gen9\\_TSG\\_fr](http://www.hpe.com/support/Gen9_TSG_fr))
- Spanish ([http://www.hpe.com/support/Gen9\\_TSG\\_es](http://www.hpe.com/support/Gen9_TSG_es))
- German ([http://www.hpe.com/support/Gen9\\_TSG\\_de](http://www.hpe.com/support/Gen9_TSG_de))
- Japanese ([http://www.hpe.com/support/Gen9\\_TSG\\_ja](http://www.hpe.com/support/Gen9_TSG_ja))
- Simplified Chinese ([http://www.hpe.com/support/Gen9\\_TSG\\_zh\\_cn](http://www.hpe.com/support/Gen9_TSG_zh_cn))

The *HPE ProLiant Gen9 Troubleshooting Guide, Volume II: Error Messages* provides a list of error messages and information to assist with interpreting and resolving error messages on ProLiant servers and server blades. To view the guide, select a language:

- English ([http://www.hpe.com/support/Gen9\\_EMG\\_en](http://www.hpe.com/support/Gen9_EMG_en))
- French ([http://www.hpe.com/support/Gen9\\_EMG\\_fr](http://www.hpe.com/support/Gen9_EMG_fr))
- Spanish ([http://www.hpe.com/support/Gen9\\_EMG\\_es](http://www.hpe.com/support/Gen9_EMG_es))
- German ([http://www.hpe.com/support/Gen9\\_EMG\\_de](http://www.hpe.com/support/Gen9_EMG_de))
- Japanese ([http://www.hpe.com/support/Gen9\\_EMG\\_ja](http://www.hpe.com/support/Gen9_EMG_ja))
- Simplified Chinese ([http://www.hpe.com/support/Gen9\\_EMG\\_zh\\_cn](http://www.hpe.com/support/Gen9_EMG_zh_cn))

# Diagnostic tools

## Product QuickSpecs

For more information about product features, specifications, options, configurations, and compatibility, see the product QuickSpecs on the Hewlett Packard Enterprise website (<http://www.hpe.com/info/qs>).

## HPE iLO

The iLO 4 subsystem is a standard component of ProLiant servers that simplifies initial server setup, server health monitoring, power and thermal optimization, and remote server administration. The iLO 4 subsystem includes an intelligent microprocessor, secure memory, and a dedicated network interface. This design makes iLO 4 independent of the host server and its operating system.

iLO 4 enables and manages the Active Health System (on page 52) and also features Agentless Management. All key internal subsystems are monitored by iLO 4. If enabled, SNMP alerts are sent directly by iLO 4 regardless of the host operating system or even if no host operating system is installed.

Using iLO 4, you can do the following:

- Access a high-performance and secure Integrated Remote Console to the server from anywhere in the world if you have a network connection to the server.
- Use the shared .NET Integrated Remote Console to collaborate with up to four server administrators.
- Remotely mount high-performance Virtual Media devices to the server.
- Securely and remotely control the power state of the managed server.
- Implement true Agentless Management with SNMP alerts from iLO, regardless of the state of the host server.
- Download the Active Health System log.
- Register for HPE remote support.
- Use iLO Federation to manage multiple servers from one system running the iLO web interface.
- Use Virtual Power and Virtual Media from the GUI, the CLI, or the iLO scripting toolkit for many tasks, including the automation of deployment and provisioning.
- Control iLO 4 by using a remote management tool.

For more information about iLO 4 features, see the iLO 4 documentation on the Hewlett Packard Enterprise website (<http://www.hpe.com/info/ilo/docs>).

The iLO 4 hardware and firmware features and functionality, such as NAND size and embedded user partition, vary depending on the server model. For a complete list of supported features and functionality, see the iLO 4 QuickSpecs on the Hewlett Packard Enterprise website (<http://www.hpe.com/info/Quickspecs-iLO>).

## Active Health System

The HPE Active Health System provides the following features:

- Combined diagnostics tools/scanners
- Always on, continuous monitoring for increased stability and shorter downtimes

- Rich configuration history
- Health and service alerts
- Easy export and upload to Service and Support

The Active Health System monitors and records changes in the server hardware and system configuration. The Active Health System assists in diagnosing problems and delivering rapid resolution if server failures occur.

The Active Health System collects the following types of data:

- Server model
- Serial number
- Processor model and speed
- Storage capacity and speed
- Memory capacity and speed
- Firmware/BIOS

Active Health System does not collect information about Active Health System users' operations, finances, customers, employees, partners, or data center, such as IP addresses, host names, user names, and passwords. Active Health System does not parse or change operating system data from third-party error event log activities, such as content created or passed through by the operating system.

The data that is collected is managed according to the Hewlett Packard Enterprise Data Privacy policy. For more information see the Hewlett Packard Enterprise website (<http://www.hpe.com/info/privacy>).

The Active Health System, in conjunction with the system monitoring provided by Agentless Management or SNMP Pass-thru, provides continuous monitoring of hardware and configuration changes, system status, and service alerts for various server components.

The Agentless Management Service is available in the SPP, which can be downloaded from the Hewlett Packard Enterprise website (<http://www.hpe.com/servers/spp/download>). The Active Health System log can be downloaded manually from iLO 4 or HPE Intelligent Provisioning and sent to Hewlett Packard Enterprise.

For more information, see the following documents:

- *iLO User Guide* on the Hewlett Packard Enterprise website (<http://www.hpe.com/info/ilo/docs>)
- *Intelligent Provisioning User Guide* on the Hewlett Packard Enterprise website (<http://www.hpe.com/info/intelligentprovisioning/docs>)

## HPE ProLiant Pre-boot Health Summary

If the server will not start up, you can use iLO to display diagnostic information on an external monitor. This feature is supported on servers that support external video and have a UID button or an SUV connector. When power is available to the server but the server is not powered on, iLO runs on auxiliary power and can take control of the server video adapter to display the HPE ProLiant Pre-boot Health Summary.

For additional information, see the following documents:

- *iLO 4 User Guide* — See the Hewlett Packard Enterprise website (<http://www.hpe.com/info/ilo/docs>).
- *ProLiant Gen9 Troubleshooting Guide, Volume I: Troubleshooting* — See "Troubleshooting Resources (on page 51)."

# Integrated Management Log

The IML records hundreds of events and stores them in an easy-to-view form. The IML timestamps each event with 1-minute granularity.

You can view recorded events in the IML in several ways, including the following:

- From within HPE SIM
- From within UEFI System Utilities ("[HPE UEFI System Utilities](#)" on page 54)
- From within the Embedded UEFI shell
- From within operating system-specific IML viewers:
  - For Windows: IML Viewer
  - For Linux: IML Viewer Application
- From within the iLO web interface
- From within Insight Diagnostics ("[HPE Insight Diagnostics](#)" on page 55)

## HPE UEFI System Utilities

The UEFI System Utilities is embedded in the system ROM. The UEFI System Utilities enable you to perform a wide range of configuration activities, including:

- Configuring system devices and installed options
- Enabling and disabling system features
- Displaying system information
- Selecting the primary boot controller
- Configuring memory options
- Selecting a language
- Launching other pre-boot environments such as the Embedded UEFI Shell and Intelligent Provisioning

For more information on the UEFI System Utilities, see the *HPE UEFI System Utilities User Guide for HPE ProLiant Gen9 Servers* on the Hewlett Packard Enterprise website (<http://www.hpe.com/info/uefi/docs>).

Scan the QR code located at the bottom of the screen to access mobile-ready online help for the UEFI System Utilities and UEFI Shell. For on-screen help, press **F1**.

## Using UEFI System Utilities

To use the System Utilities, use the following keys.

Action	Key
Access System Utilities	F9 during server POST
Navigate menus	Up and Down arrows
Select items	Enter
Save selections	F10
Access Help for a highlighted configuration option	F1

Default configuration settings are applied to the server at one of the following times:

- Upon the first system power-up

- After defaults have been restored

Default configuration settings are sufficient for typical server operations; however, you can modify configuration settings as needed. The system prompts you for access to the System Utilities each time the system is powered up.

## Embedded Diagnostics option

The system BIOS in all ProLiant Gen9 servers includes an Embedded Diagnostics option in the ROM. The Embedded Diagnostics option can run comprehensive diagnostics of the server hardware, including processors, memory, drives, and other server components.

For more information on the Embedded Diagnostics option, see the *HPE UEFI System Utilities User Guide for HPE ProLiant Gen9 Servers* on the Hewlett Packard Enterprise website (<http://www.hpe.com/info/uefi/docs>).

## Re-entering the server serial number and product ID

After you replace the system board, you must re-enter the server serial number and the product ID.

1. During the server startup sequence, press the **F9** key to access UEFI System Utilities.
2. Select the **System Configuration > BIOS/Platform Configuration (RBSU) > Advanced Options > Advanced System ROM Options > Serial Number**, and then press the **Enter** key.
3. Enter the serial number and press the **Enter** key. The following message appears:  

```
The serial number should only be modified by qualified service personnel.
This value should always match the serial number located on the chassis.
```
4. Press the **Enter** key to clear the warning.
5. Enter the serial number and press the **Enter** key.
6. Select **Product ID**. The following warning appears:  

```
Warning: The Product ID should ONLY be modified by qualified service
personnel. This value should always match the Product ID located on the
chassis.
```
7. Enter the product ID and press the **Enter** key.
8. Press the **F10** key to confirm exiting System Utilities. The server automatically reboots.

## HPE Insight Diagnostics

The Insight Diagnostics is a proactive server management tool, available in both offline and online versions, that provides diagnostics and troubleshooting capabilities to assist IT administrators who verify server installations, troubleshoot problems, and perform repair validation.

The Insight Diagnostics Offline Edition performs various in-depth system and component testing while the OS is not running. To run this utility, boot the server using Intelligent Provisioning.

The Insight Diagnostics Online Edition is a web-based application that captures system configuration and other related data needed for effective server management. Available in Microsoft Windows and Linux versions, the utility helps to ensure proper system operation.

For more information or to download the utility, see the Hewlett Packard Enterprise website (<http://www.hpe.com/info/InsightDiagnostics>). The Insight Diagnostics Online Edition is also available in the SPP.

## HPE Insight Diagnostics survey functionality

Insight Diagnostics ("HPE Insight Diagnostics" on page 55) provides survey functionality that gathers critical hardware and software information on ProLiant servers.

This functionality supports operating systems that are supported by the server. For operating systems supported by the server, see the Hewlett Packard Enterprise website.

(<http://www.hpe.com/info/supportos>)

If a significant change occurs between data-gathering intervals, the survey function marks the previous information and overwrites the survey data files to reflect the latest changes in the configuration.

Survey functionality can be installed through the SPP.

## HPE Insight Remote Support

Hewlett Packard Enterprise strongly recommends that you register your device for remote support to enable enhanced delivery of your Hewlett Packard Enterprise warranty, HPE support services, or Hewlett Packard Enterprise contractual support agreement. Insight Remote Support supplements your monitoring continuously to ensure maximum system availability by providing intelligent event diagnosis, and automatic, secure submission of hardware event notifications to Hewlett Packard Enterprise, which will initiate a fast and accurate resolution, based on your product's service level. Notifications can be sent to your authorized Hewlett Packard Enterprise Channel Partner for onsite service, if configured and available in your country.

For more information, see *Insight Remote Support and Insight Online Setup Guide for ProLiant Servers and BladeSystem c-Class Enclosures* on the Hewlett Packard Enterprise website (<http://www.hpe.com/info/insightremotesupport/docs>). Insight Remote Support is available as part of Hewlett Packard Enterprise Warranty, HPE support services, or Hewlett Packard Enterprise contractual support agreement.

## USB support

Hewlett Packard Enterprise provides both standard USB 2.0 support and legacy USB 2.0 support. Standard support is provided by the OS through the appropriate USB device drivers. Before the OS loads, Hewlett Packard Enterprise provides support for USB devices through legacy USB support, which is enabled by default in the system ROM.

Legacy USB support provides USB functionality in environments where USB support is not available normally. Specifically, Hewlett Packard Enterprise provides legacy USB functionality for the following:

- POST (system boot)
- UEFI System Utilities
- Pre-boot UEFI shell
- DOS
- Operating environments which do not provide native USB support

## External USB functionality

Hewlett Packard Enterprise provides external USB support to enable local connection of USB devices for server administration, configuration, and diagnostic procedures.

For additional security, external USB functionality can be disabled through USB options in UEFI System Utilities.

## Automatic Server Recovery

ASR is a feature that causes the system to restart when a catastrophic operating system error occurs, such as a blue screen, ABEND (does not apply to HPE ProLiant DL980 Servers), or panic. A system fail-safe timer, the ASR timer, starts when the System Management driver, also known as the Health



Driver, is loaded. When the operating system is functioning properly, the system periodically resets the timer. However, when the operating system fails, the timer expires and restarts the server.

ASR increases server availability by restarting the server within a specified time after a system hang. At the same time, the SIM console notifies you by sending a message to a designated pager number that ASR has restarted the system. You can disable ASR from the System Management Homepage or through RBSU.

# Component identification

## Front panel components

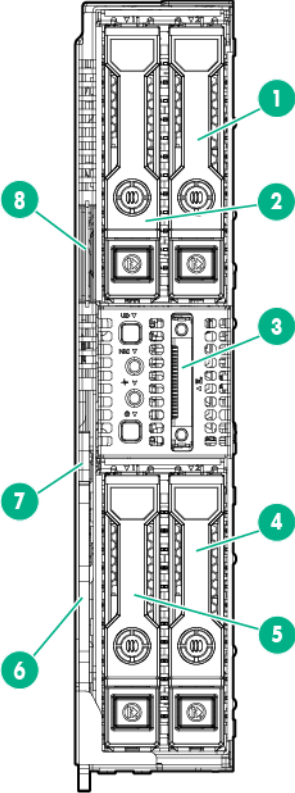

Item	Description
1	Drive bay*
2	Drive bay*
3	SUV connector
4	Drive bay*
5	Drive bay*
6	Server tray release lever
7	Server tray release latch
8	Serial label pull tab

\*For more information about drive bay numbering, see "Drive numbering (on page 62)."

# Front panel LEDs and buttons

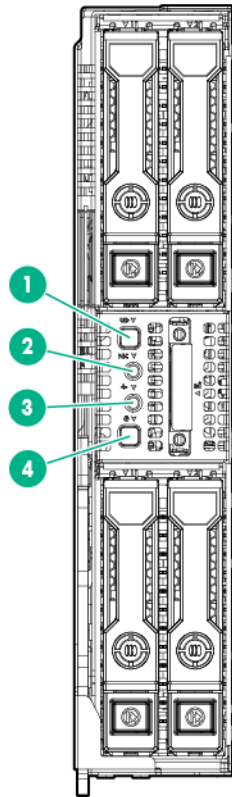

Item	Description	Status
1	UID button/LED*	Solid blue = Activated Flashing blue (1 Hz/cycle per sec) = Remote management or firmware upgrade in progress Off = Deactivated
2	NIC status LED*	Solid green = Link to network Flashing green (1 Hz/cycle per sec) = Network active Off = No network activity
3	Health LED*	Solid green = Normal Flashing green (1 Hz/cycle per sec) = iLO is rebooting Flashing amber = System degraded Flashing red (1 Hz/cycle per sec) = System critical
4	Power On/Standby button and system power LED*	Solid green = System on Flashing green (1 Hz/cycle per sec) = Performing power on sequence Solid amber = System in standby Off = No power present**

\*When all four LEDs described in this table flash simultaneously, a power fault has occurred. For more information, see "Front panel LED power fault codes (on page 59)."

\*\*Facility power is not present, power cord is not attached, no power supplies are installed, power supply failure has occurred, or the power button cable is disconnected.

## Front panel LED power fault codes

The following table provides a list of power fault codes, and the subsystems that are affected. Not all power faults are used by all servers.

Subsystem	Front panel LED behavior
System board	1 flash
Processor	2 flashes
Memory	3 flashes
Riser board PCIe slots	4 flashes
FlexibleLOM	5 flashes
Removable HPE Flexible Smart Array controller/Smart SAS HBA controller	6 flashes
System board PCIe slots	7 flashes
Power backplane or storage backplane	8 flashes
Power supply	9 flashes

For more information, see "Front panel LEDs and buttons (on page 59)."

## System board components

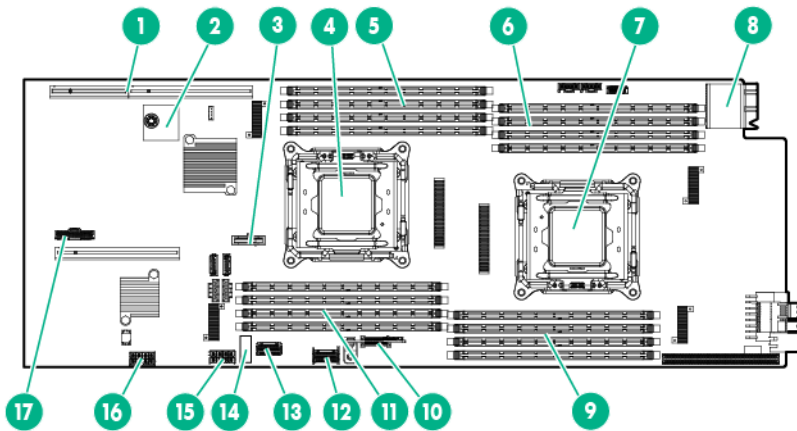

Item	Description
1	PCIe riser board connector
2	TPM connector
3	System battery
4	Processor 2
5	Processor 2 DIMMs
6	Processor 1 DIMMs
7	Processor 1
8	Rear I/O connector
9	Processor 1 DIMMs
10	MicroSD card slot riser
11	Processor 2 DIMMs
12	SATA connector 1
13	SATA connector 2

Item	Description
14	System maintenance switch
15	Backplane power connector
16	Backplane power connector*
17	Front panel LED board cable connector

\*This connector is required only on the 6-GB drive backplane configuration.

## DIMM slot locations

DIMM slots are numbered sequentially (1 through 8) for each processor. The supported AMP modes use the alpha assignments for population order, and the slot numbers designate the DIMM slot ID for spare replacement.

The arrow indicates the front of the server.

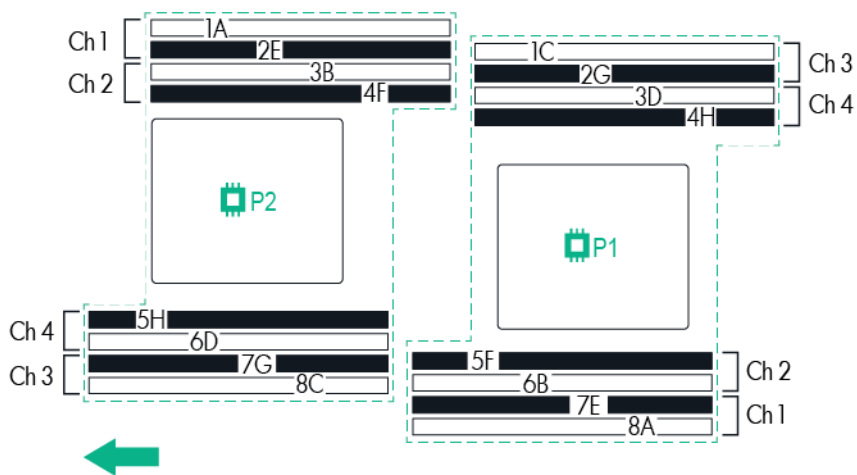

## System maintenance switch

Position	Default	Function
S1	Off	Off = iLO security is enabled. On = iLO security is disabled.
S2	Off	Off = System configuration can be changed. On = System configuration is locked.
S3	Off	Reserved
S4	Off	Reserved
S5	Off	Off = Power-on password is enabled. On = Power-on password is disabled.
S6	Off	Off = No function. On = ROM reads system configuration as invalid.
S7	Off	Off = Set default boot mode to UEFI. On = Set default boot mode to legacy.
S8	—	Reserved
S9	—	Reserved

Position	Default	Function
S10	—	Reserved
S11	—	Reserved
S12	—	Reserved

To access the redundant ROM, set S1, S5, and S6 to On.

When the system maintenance switch position 6 is set to the On position, the system is prepared to erase all system configuration settings from both CMOS and NVRAM.

**CAUTION:** Clearing CMOS and/or NVRAM deletes configuration information. Be sure to properly configure the server or data loss could occur.

## Drive numbering

Depending on the server configuration, the drive bay numbering for the server varies. For more information, see the section that represents your server configuration:

- Hot-plug drive numbering (single 12G drive backplane)
- Hot-plug drive numbering (dual 6G drive backplanes)
- Non-hot-plug drive numbering

### Hot-plug drive numbering (single 12G drive backplane)

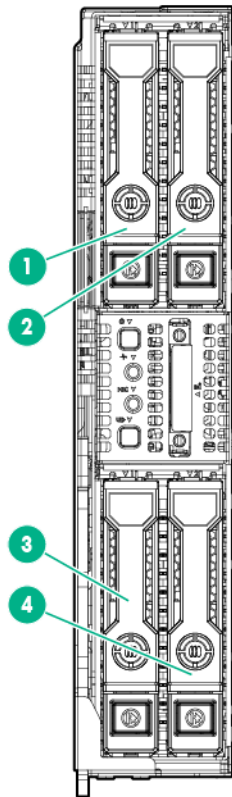

Item	Description
1	Drive bay 1
2	Drive bay 2

Item	Description
3	Drive bay 3
4	Drive bay 4

## Hot-plug drive numbering (dual 6G drive backplanes)

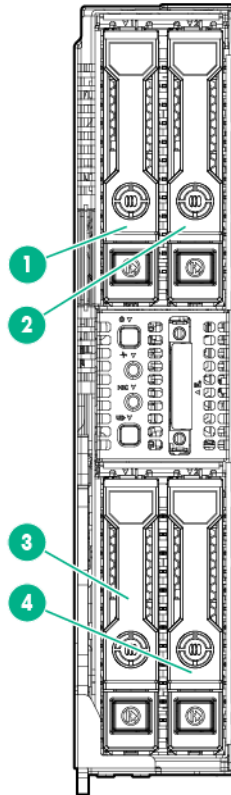

Item	Description
1	Drive box 1, drive bay 1
2	Drive box 1, drive bay 2
3	Drive box 2, drive bay 1
4	Drive box 2, drive bay 2

## Non-hot-plug drive numbering

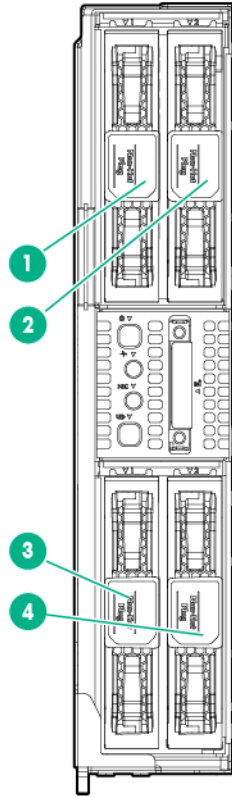

Item	Description
1	Drive bay 1
2	Drive bay 2
3	Drive bay 3
4	Drive bay 4

## Hot-plug drive LED definitions

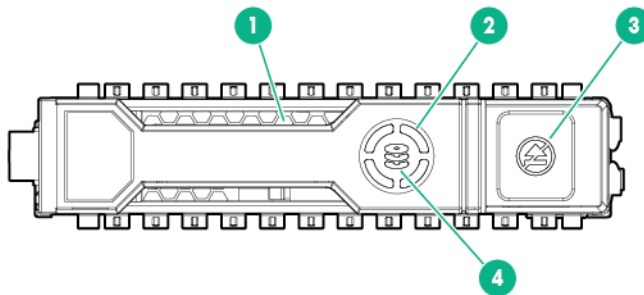

Item	LED	Status	Definition
1	Locate	Solid blue	The drive is being identified by a host application.
		Flashing blue	The drive carrier firmware is being updated or requires an update.
2	Activity ring	Rotating green	Drive activity
		Off	No drive activity



Item	LED	Status	Definition
3	Do not remove	Solid white	Do not remove the drive. Removing the drive causes one or more of the logical drives to fail.
		Off	Removing the drive does not cause a logical drive to fail.
4	Drive status	Solid green	The drive is a member of one or more logical drives.
		Flashing green	The drive is rebuilding or performing a RAID migration, strip size migration, capacity expansion, or logical drive extension, or is erasing.
		Flashing amber/green	The drive is a member of one or more logical drives and predicts the drive will fail.
		Flashing amber	The drive is not configured and predicts the drive will fail.
		Solid amber	The drive has failed.
	Off	The drive is not configured by a RAID controller.	

## I/O module bay numbering

I/O modules are specific to each server and are installed in the rear of the chassis.

The chassis has ten I/O module bays located in the rear of the chassis.

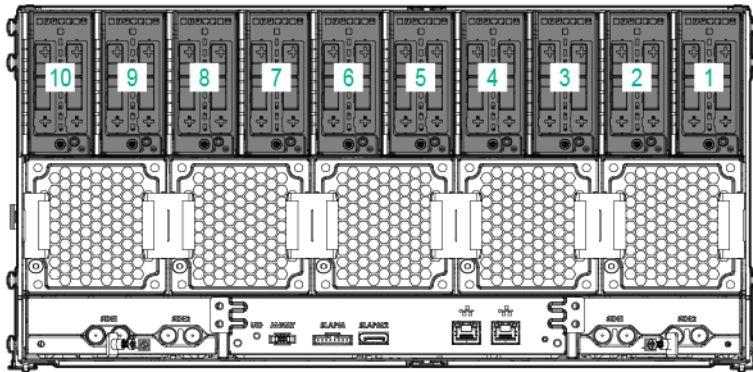

For more information about product features, specifications, options, configurations, and compatibility, see the product QuickSpecs on the Hewlett Packard Enterprise website (<http://www.hpe.com/info/qs>).

# I/O module slot definitions

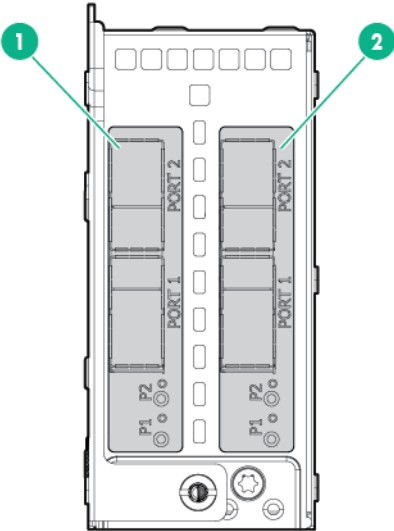

Item	Dual FlexibleLOM I/O module slot description	PCIe/FlexibleLOM I/O module slot description
1	FlexibleLOM 1 — PCIe3 x16 (16, 8, 4, 2, 1)	FlexibleLOM — PCIe3 x8 (8, 4, 2, 1)
2	FlexibleLOM 2 — PCIe3 x8 (8, 4, 2, 1)	PCIe LP — PCIe3 x16 (16, 8, 4, 2, 1)

# Cabling

## Internal server cabling

This section provides guidelines that help you make informed decisions about cabling the server and hardware options to optimize performance.



**CAUTION:** When routing cables, always be sure that the cables are not in a position where they can be pinched or crimped.

## Drive cabling

Review the drive cabling depending on the drive backplane and the controller installed in the server. All blue cables represent the drive power cables and the green cables are Mini-SAS data cables.

- 12-GB backplane configuration (four drives) with the embedded controller

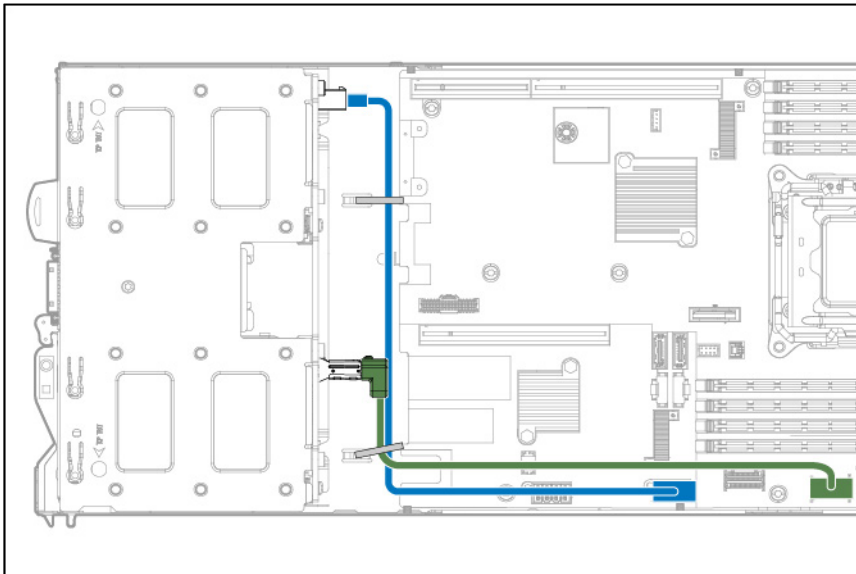

- 6-GB backplanes (one two-drive backplane per drive box) with the embedded controller

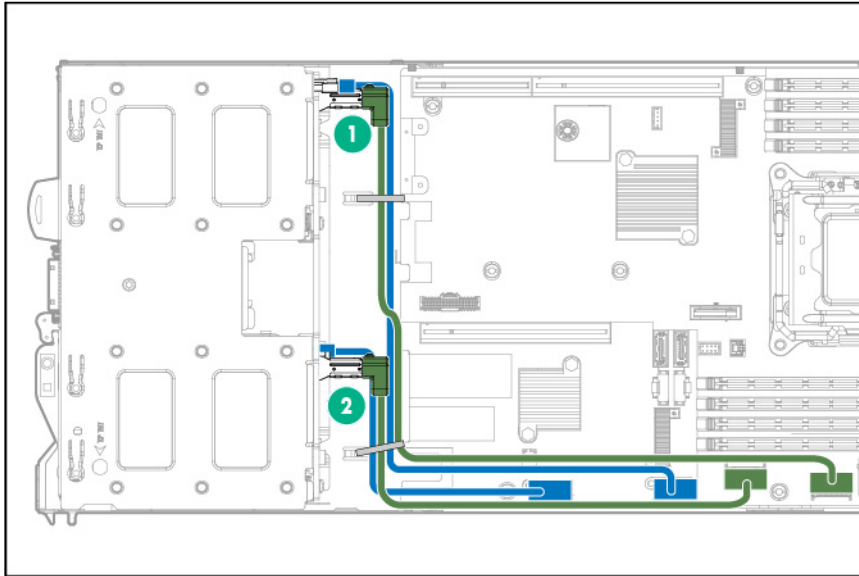

- 12-GB backplane with the HPE Smart Array P440 Controller

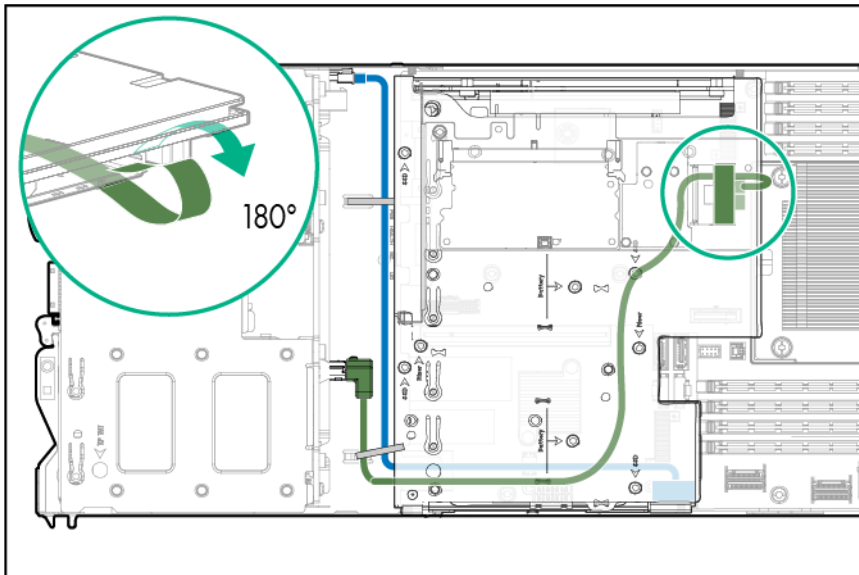

- 12-GB backplane with the HPE H240 Smart Host Bus Adapter

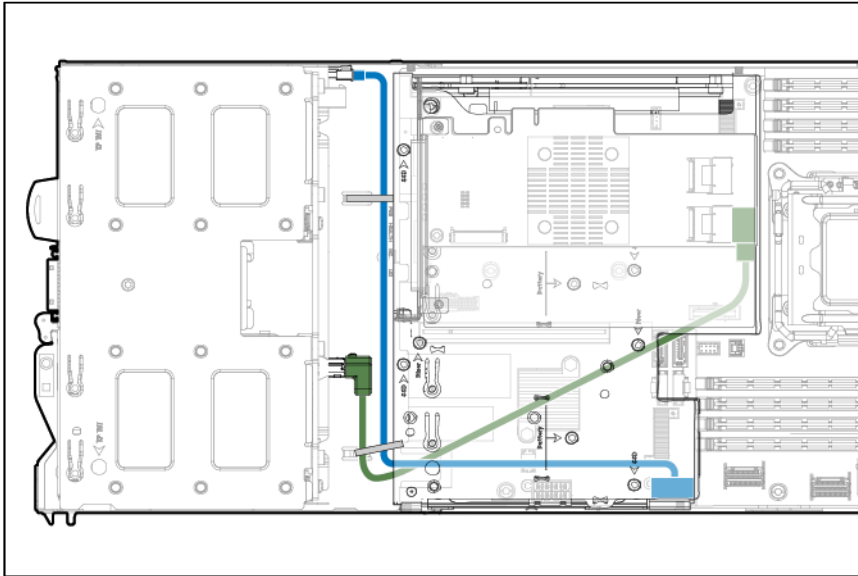

- 6-GB backplanes with the HPE H240 Smart Host Bus Adapter

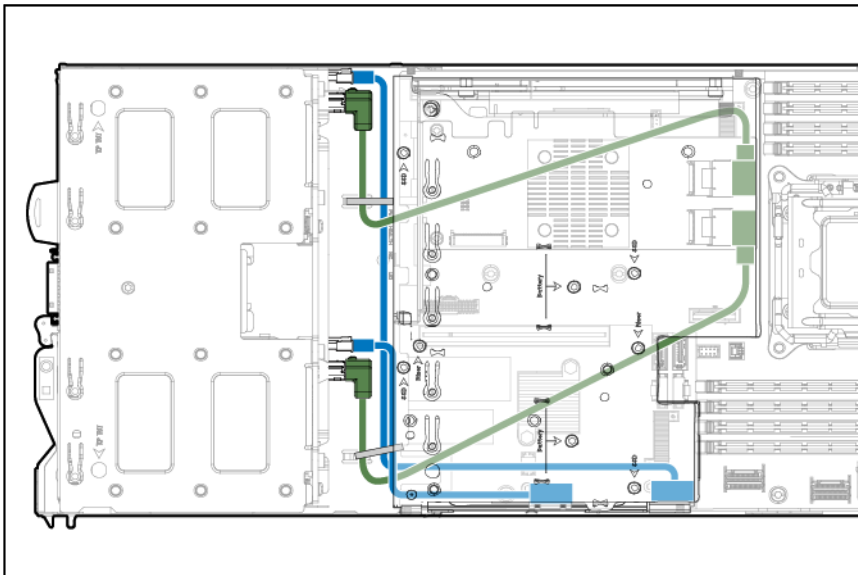

- Non-hot plug-drives with the embedded controller

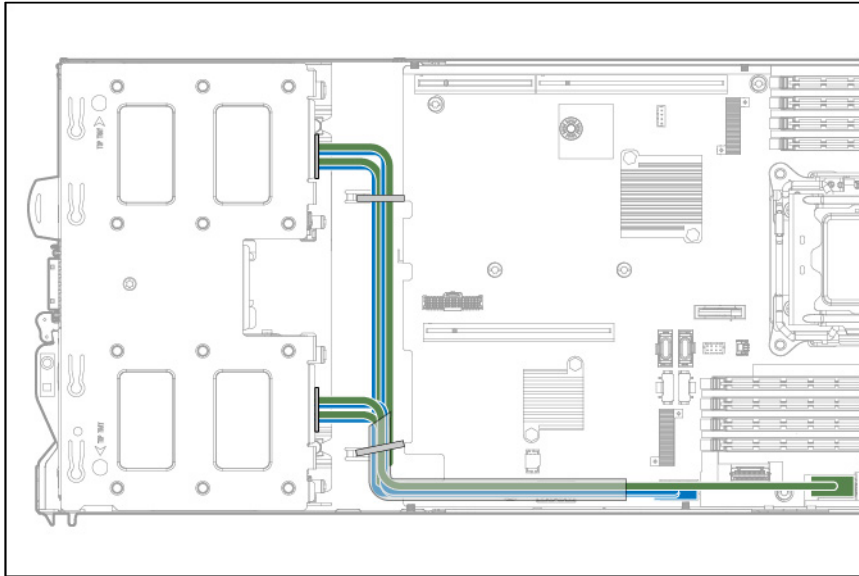

## HPE Smart Storage Battery cabling

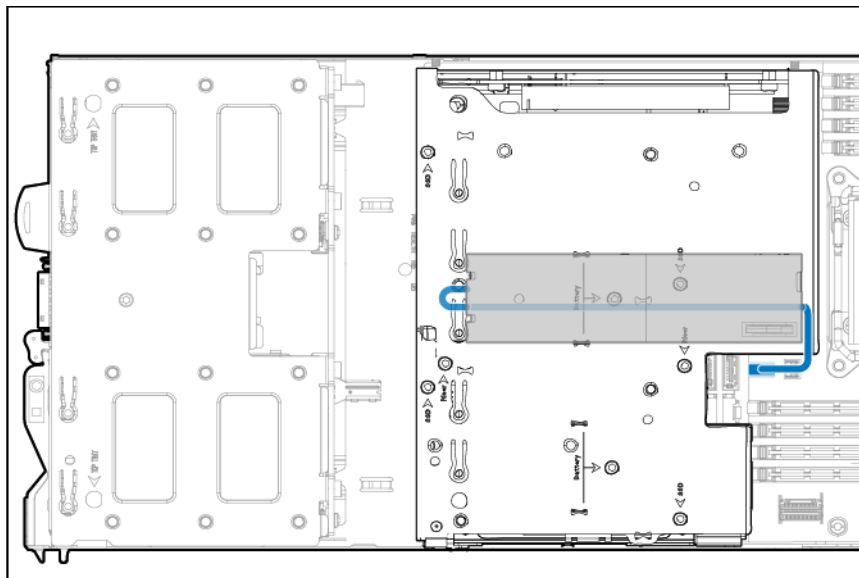

## Front panel LED board assembly cabling

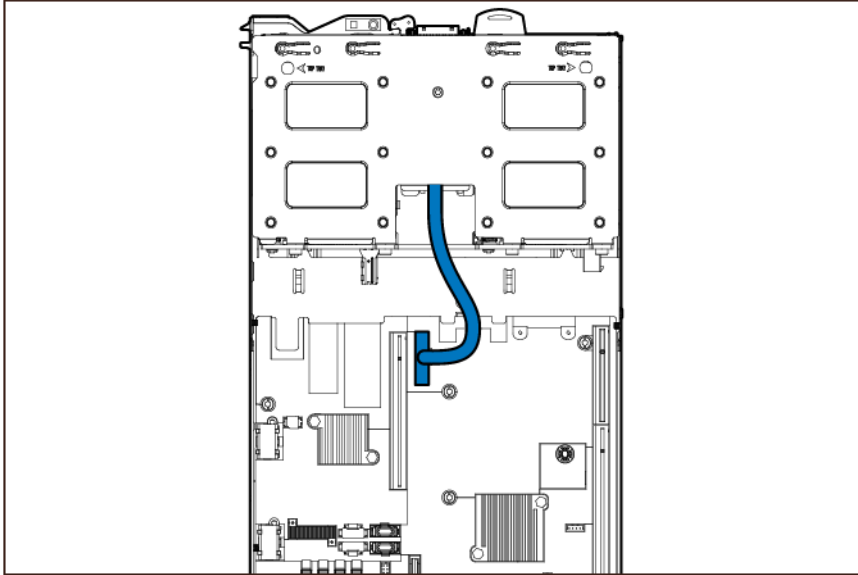

## SUV cable connectors

△ **CAUTION:** Before disconnecting the SUV cable from the connector, always squeeze the release buttons on the sides of the connector. Failure to do so can result in damage to the equipment.

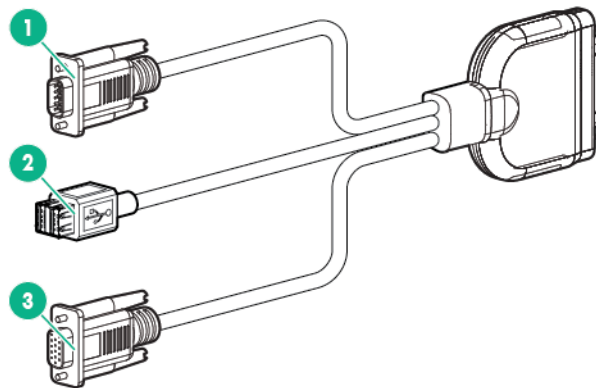

Item	Connector	Description
1	Serial	For trained personnel to connect a null modem serial cable and perform advanced diagnostic procedures
2	USB*	For connecting up to two USB devices
3	Video	For connecting a video monitor

\*The USB connectors on the SUV cable do not support devices that require greater than a 500mA power source.

# Specifications

## Environmental specifications

Specification	Value
<b>Temperature range*</b>	—
Operating	10°C to 35°C (50°F to 95°F)
Shipping	-40°C to 70°C (-40°F to 158°F)
Maximum wet bulb temperature	28°C (82.4°F)
<b>Relative humidity (noncondensing)**</b>	—
Operating	10% to 90%
Nonoperating	5% to 95%

\* All temperature ratings shown are for sea level. An altitude derating of 1°C per 300 m (1.8°F per 1,000 ft) to 3,048 m (10,000 ft) is applicable. No direct sunlight is allowed.

\*\* Storage maximum humidity of 95% is based on a maximum temperature of 45°C (113°F). Altitude maximum for storage corresponds to a pressure minimum of 70 kPa.

## Server specifications

Specification	Value
Height	21.15 cm (8.33 in)
Depth	70.79 cm (27.87 in)
Width	4.33 cm (1.70 in)
Weight (maximum: two processors, four hard drives)	6.80 kg (15.00 lb)



# Acronyms and abbreviations

ABEND

abnormal end

AMP

Advanced Memory Protection

ASR

Automatic Server Recovery

CSR

Customer Self Repair

HPE SIM

HPE Systems Insight Manager

iLO

Integrated Lights-Out

IML

Integrated Management Log

NVRAM

nonvolatile memory

PCI

peripheral component interconnect

PCIe

Peripheral Component Interconnect Express

POST

Power-On Self Test

SAS

serial attached SCSI

SD

Secure Digital

**SFF**

small form factor

**SIM**

Systems Insight Manager

**SPP**

Service Pack for ProLiant

**SUV**

serial, USB, video

**TPM**

Trusted Platform Module

**UEFI**

Unified Extensible Firmware Interface

**UID**

unit identification

**USB**

universal serial bus

# Documentation feedback

Hewlett Packard Enterprise is committed to providing documentation that meets your needs. To help us improve the documentation, send any errors, suggestions, or comments to Documentation Feedback (<mailto:docsfeedback@hpe.com>). When submitting your feedback, include the document title, part number, edition, and publication date located on the front cover of the document. For online help content, include the product name, product version, help edition, and publication date located on the legal notices page.

# Index

## A

ASR (Automatic Server Recovery) 56  
Automatic Server Recovery (ASR) 56

## B

battery 37, 41  
bay numbering, I/O module 65  
buttons 58  
buttons, front panel 58

## C

cable routing diagrams 71  
cable, routing 71  
cable, SUV 71  
cables 67  
cables, overview 67  
cabling 67, 71  
cabling, server 67, 71  
cache module 36  
cautions 25, 26  
CMOS 61  
components 15, 25, 58  
components, front panel 58  
components, identification 15, 58  
components, mechanical 15  
components, server 15  
connectors 58  
controller 36  
controller components 58  
CSR (customer self repair) 5  
customer self repair (CSR) 5

## D

definitions 64  
diagnosing problems 51  
diagnostic tools 52, 55, 56  
diagnostics utility 55  
dimensions and weight 72  
DIMM numbering 61  
DIMM slot locations 61  
DIMMs 15, 34, 61  
documentation 75  
documentation feedback 75  
drive 30  
drive blank 15  
drive cabling 15, 67  
drive cage assembly 15, 38

drive cage assembly, removal 38  
drives 30, 64  
drives, determining status of 64  
drives, hot-plug 30  
drives, removing 30

## E

electrical 25  
electrostatic discharge 25  
environmental requirements 72  
environmental specifications 72  
error messages 51  
expansion board 36  
external USB functionality 56

## F

features 58  
firmware upgrade utility, troubleshooting 51  
front panel components 58  
front panel display cable 71  
front panel LED board assembly 40  
front panel LED board assembly cabling 71  
front panel LEDs 15, 59

## G

guidelines, troubleshooting 51

## H

health driver 56  
heatsink 15, 42  
Hewlett Packard Enterprise Technical Support 5  
hot-plug drive 30  
hot-plug drive, removing 30  
HPE Insight Diagnostics 55, 56  
HPE Insight Diagnostics survey functionality 55  
HPE Insight Remote Support software 56  
HPE Systems Insight Manager (SIM) 54, 55  
HPE Trusted Platform Module option 50  
humidity 72

## I

I/O module 65, 66  
I/O module bay numbering 65  
I/O module components 22  
I/O module slot definitions 66  
I/O module, removing 28  
identifying components 58  
illustrated parts catalog 15

- iLO (Integrated Lights-Out) 52, 54
- IML (Integrated Management Log) 54
- Insight Diagnostics 55
- installing the server 29
- installing the server into the rack 29
- Integrated Lights-Out (iLO) 52, 54
- Integrated Management Log (IML) 54
- Intelligent Provisioning 54, 55
- internal cables 67

## L

- LED indicators 59
- LED, health 59
- LED, NIC 59
- LED, power 59
- LED, system power 59
- LED, UID 59
- LEDs 64
- LEDs, drive 64
- LEDs, front panel 64
- LEDs, power fault 59
- LEDs, SAS drive 64
- LEDs, troubleshooting 51
- legacy USB support 56

## M

- maintenance 25
- management tools 52
- mechanical components 15
- memory 34

## N

- NIC activity LED 59

## O

- operating system crash 56

## P

- part numbers 15
- PCI riser board assembly 15
- PCI riser board assembly, removal 35
- POST error messages 51
- power fault 59
- power protection specifications 72
- powering down 26
- power-on password 61
- preparation procedures 26
- problem diagnosis 51, 52
- processor 15, 44
- processor air baffle 34
- Product ID 49, 55

## Q

- QuickSpecs 52

## R

- re-entering the server serial number 49, 55
- removal and replacement procedures 25
- remove a server 27
- removing a drive 30
- removing the server 27
- removing the system board 47
- replacement procedures 25
- required tools 25
- requirements, environmental 72
- ROM legacy USB support 56

## S

- safety considerations 25
- safety information 25
- SAS cabling 15
- SAS drives 15, 64
- SATA drives 15
- serial connector 71
- serial number 49, 55
- server blade components 58
- server specifications 72
- server, power down 26
- server, removal 27
- Service Pack for ProLiant 55
- slot definitions 66
- software 53
- spare part numbers 15
- specifications 72
- specifications, environmental 72
- specifications, server 72
- static electricity 25
- supported servers 51
- supported targets 51
- SUV cable 15, 71
- SUV connector 71
- symbols on equipment 25
- system battery 15, 41
- system board 15, 47
- system board components 60
- system components 58
- system maintenance switch 61

## T

- technical support 5
- temperature requirements 72
- tools 25
- TPM (Trusted Platform Module) 15, 50
- TPM, connector 15
- troubleshooting 51
- troubleshooting resources 51, 52
- troubleshooting, firmware upgrade utility 51

Trusted Platform Module (TPM) 50

## **U**

UID button 58

UID LED 58

USB (universal serial bus) 56

USB connector 71

USB support 56

utilities 52, 54

## **V**

video connector 71

## **W**

warnings 26

warranty 5

weight 72