

# **HPE Aruba Networking 8325 Switch Series**

**Installation and Getting Started Guide**



**Hewlett Packard**  
Enterprise

## Copyright Information

© Copyright 2024 Hewlett Packard Enterprise Development LP.

## Open Source Code

This product includes code licensed under certain open source licenses which require source compliance. The corresponding source for these components is available upon request. This offer is valid to anyone in receipt of this information and shall expire three years following the date of the final distribution of this product version by Hewlett Packard Enterprise Company. To obtain such source code, please check if the code is available in the HPE Software Center at <https://myenterpriselicense.hpe.com/cwp-ui/software> but, if not, send a written request for specific software version and product for which you want the open source code. Along with the request, please send a check or money order in the amount of US \$10.00 to:

Hewlett Packard Enterprise Company  
Attn: General Counsel  
WW Corporate Headquarters  
1701 E Mossy Oaks Rd, Spring, TX 77389  
United States of America



**Notices**

The information contained herein is subject to change without notice. The only warranties for Hewlett Packard Enterprise products and services are set forth in the express warranty statements accompanying such products and services. Nothing herein should be construed as constituting an additional warranty. Hewlett Packard Enterprise shall not be liable for technical or editorial errors or omissions contained herein.

Confidential computer software: Valid license from Hewlett Packard Enterprise required for possession, use, or copying. Consistent with FAR 12.211 and 12.212, Commercial Computer Software, Computer Software Documentation, and Technical Data for Commercial Items are licensed to the U.S. Government under vendor's standard commercial license.

Links to third-party websites take you outside the Hewlett Packard Enterprise website. Hewlett Packard Enterprise has no control over and is not responsible for information outside the Hewlett Packard Enterprise website.

**Acknowledgments**

All third-party marks are property of their respective owners.

---

<b>Contents</b> .....	<b>4</b>
<b>About this Document</b> .....	<b>7</b>
Applicable Products .....	7
Related Publications .....	7
<b>Introducing the HPE Aruba Networking 8325 Switch</b> .....	<b>8</b>
Overview .....	8
Front of the Switch .....	10
8325-48Y8C JL624A, JL625A, JL857A, and JL858A Switches .....	10
8325-32C JL626A, JL627A, JL859A, and JL860A Switches .....	10
Network Ports .....	11
Management Ports .....	14
Console Port .....	14
Out-of-band Management (OOBM) Port .....	14
USB-A Port .....	15
Chassis LEDs on the Front of the Switch .....	15
Port LEDs on the Front of the Switch .....	18
Reset Button .....	21
Switch Product Label .....	21
Back of the Switch .....	22
Power Supplies .....	24
Power Supply Status LED .....	26
Load Sharing .....	26
Mixing AC and DC Power Supplies .....	26
Redundancy .....	26
Hot Swapping .....	26
Fan Assemblies .....	27
Fan Assembly Status LED .....	29
Switch Features .....	29
<b>Installing the Switch</b> .....	<b>31</b>
Included Parts .....	31
Japan Power Cord Warning .....	32
Parts not Included .....	32
Installation Procedures .....	32
Summary .....	32
Installation Precautions .....	33
Prepare the Installation Site .....	35
Install Power Supplies .....	35
Install Fan Assemblies .....	36
Power-on the Switch and Check the LEDs .....	37
AC Power Supplies .....	37
DC Power Supplies .....	37
Check LEDs for Proper Switch Operation .....	38
Power off the Switch .....	40
Mount the Switch .....	40
Mounting an HPE Aruba Networking 8325 Switch .....	40

---

Two-post Rack Mount Option .....	41
Four-Post Rack Mount Option .....	42
Install Transceivers .....	44
Removing Transceivers .....	45
Interface-Group Operation .....	46
1 GBase-T (J8177D) Transceiver Support Restrictions in the 48-port 8325 Switches	47
10 GBase-T (JL563A) Transceiver Support Restrictions in the 48-port 8325 Switches	48
Connect the Switch to a Power Source .....	48
Setup for Initial Configuration .....	49
Connect the Network Cables .....	49
Using RJ45 Out-of-band Management Port .....	50
Connecting Cables to Transceivers .....	50
<b>Initial Configuration with an Out-of-Band Serial Connection .....</b>	<b>52</b>
Terminal Configuration .....	52
Connect to a Console Port .....	52
Console Cable Pinouts .....	53
<b>Replacing Components .....</b>	<b>55</b>
Replacing a Power Supply .....	55
Replacing a Fan Assembly .....	56
<b>Troubleshooting .....</b>	<b>59</b>
Basic Troubleshooting Tips .....	59
Diagnosing with the LEDs .....	60
LED Patterns for General Switch Troubleshooting .....	60
Diagnostic Tips .....	60
Hardware Diagnostic Tests .....	63
Testing the Switch by Resetting It .....	63
Checking the Switch LEDs .....	63
Checking Console Messages .....	63
Testing Switch-to-Device Network Communications .....	63
Testing End-to-End Networking Communications .....	64
Battery .....	64
Downloading New Switch Software .....	65
Hewlett Packard Enterprise Customer Support Services .....	65
<b>Specifications .....</b>	<b>66</b>
Switch Specifications .....	66
Physical .....	66
Electrical .....	66
Power Consumption .....	67
MTBF .....	67
Environmental .....	67
Acoustics .....	68
RoHS .....	68
Standards .....	68
<b>Cabling and Technology Information .....</b>	<b>71</b>
Cabling Specifications .....	71
Technology Distance Specifications .....	73
<b>Support and Other Resources .....</b>	<b>75</b>
Accessing HPE Aruba Networking Support .....	75

---

Other Useful Sites .....	75
Accessing Updates .....	75
HPE Networking Support Portal .....	76
My Networking .....	76
Warranty Information .....	76
Regulatory Information .....	76
Additional Regulatory Information .....	76
Documentation Feedback .....	76

This document is intended for network administrators and support personnel.



The display and command line illustrated in this document are examples and might not exactly match your particular switch or environment. The switch and accessory drawings in this document are for illustration only, and may not exactly match your particular switch and accessory products.

## Applicable Products

Model	Description
JL624A	Aruba 8325-48Y8C 48p 25G SFP/SFP+/SFP28 8p 100G QSFP+/QSFP28 Front-to-Back 6 Fans and 2 PSU Bundle
JL625A	Aruba 8325-48Y8C 48p 25G SFP/SFP+/SFP28 8p 100G QSFP+/QSFP28 Back-to-Front 6 Fans and 2 PSU Bundle
JL626A	Aruba 8325-32C 32-port 100G QSFP+/QSFP28 Front-to-Back 6 Fans and 2 Power Supply Bundle
JL627A	Aruba 8325-32C 32-port 100G QSFP+/QSFP28 Back-to-Front 6 Fans and 2 Power Supply Bundle
JL857A	Aruba 8325-48Y8C 48-port 25G SFP/SFP+/SFP28 8-port 100G QSFP+/QSFP28 Front-to-Back 6 Fans 2 DC Bundle
JL858A	Aruba 8325-48Y8C 48-port 25G SFP/SFP+/SFP28 8-port 100G QSFP+/QSFP28 Back-to-Front 6 Fans 2 DC Bundle
JL859A	Aruba 8325-32C 32-port 100G QSFP+/QSFP28 Front-to-Back 6 Fans and 2 DC Bundle
JL860A	Aruba 8325-32C 32-port 100G QSFP+/QSFP28 Back-to-Front 6 Fans and 2 DC Bundle
JL635A	Aruba 8325-48Y8C 48-port 25G SFP/SFP+/SFP28 and 8-port 100G QSFP+/QSFP28 Switch
JL636A	Aruba 8325-32C 32-port 100G QSFP+/QSFP28 Switch

## Related Publications

- START HERE: Installation, Safety, and Regulatory Information for the HPE Aruba Networking 8325 Switches
- Transceiver Guide
- AOS-CX software manuals

To view and download the latest version of the above publications, visit the HPE Networking Support Portal at <https://networkingsupport.hpe.com/downloads>.

# Chapter 2

## Introducing the HPE Aruba Networking 8325 Switch

### Overview

The HPE Aruba Networking 8325 switch is a multi-port switch that can be used to build high-performance switched networks. The switch is a store-and-forward device offering low latency for high-speed networking. The HPE Aruba Networking 8325 switch also supports full network management capabilities.



These switches are intended for indoor use only. They are for use in commercial applications. A typical installation is in an environmentally controlled data center. The end-use environment may or may not be a restricted access location.

**Table 1:** *Switches Described in this Manual*

Switch	Description
Aruba 8325-48Y8C 48p 25G SFP/SFP+/SFP28 8p 100 G QSFP+/QSFP28 Front-to-Back 6 Fans and 2 PSU Bundle (JL624A)	Includes a 48-port of 1/10/25 Gbps and 8-port of 40/100 Gbps switch with six fans and two AC power supplies installed with front-to-back airflow.
Aruba 8325-48Y8C 48p 25G SFP/SFP+/SFP28 8p 100 G QSFP+/QSFP28 Back-to-Front 6 Fans and 2 PSU Bundle (JL625A)	Includes a 48-port of 1/10/25 Gbps and 8-port of 40/100 Gbps switch with six fans and two AC power supplies installed with back-to-front airflow.
Aruba 8325-48Y8C 48-port 25 G SFP/SFP+/SFP28 8-port 100 G QSFP+/QSFP28 Front-to-Back 6 Fans 2 DC Bundle (JL857A)	Includes a 48-port of 1/10/25 Gbps and 8-port of 40/100 Gbps switch with six fans and two DC power supplies installed with front-to-back airflow
Aruba 8325-48Y8C 48-port 25 G SFP/SFP+/SFP28 8-port 100 G QSFP+/QSFP28 Back-to-Front 6 Fans 2 DC Bundle (JL858A)	Includes a 48-port of 1/10/25 Gbps and 8-port of 40/100 Gbps switch with six fans and two DC power supplies installed with back-to-front airflow.
Aruba 8325-32C 32-port 100 G QSFP+/QSFP28 Front-to-Back 6 Fans and 2 Power Supply Bundle (JL626A)	Includes a 32-port of 40/100 Gbps switch with six fans and two AC power supplies installed with front-to-back airflow.
Aruba 8325-32C 32-port 100 G QSFP+/QSFP28 Back-to-Front 6 Fans and 2 Power Supply Bundle (JL627A)	Includes a 32-port of 40/100 Gbps switch with six fans and two AC power supplies installed with back-to-front airflow.
Aruba 8325-32C 32-port 100 G QSFP+/QSFP28 Front-to-Back 6 Fans and 2 DC Bundle (JL859A)	Includes a 32-port of 40/100 Gbps switch with six fans and two DC power supplies installed with front-to-back airflow.
Aruba 8325-32C 32-port 100 G QSFP+/QSFP28 Back-to-Front 6 Fans and 2 DC Bundle (JL860A)	Includes a 32-port of 40/100 Gbps switch with six fans and two DC power supplies installed with back-to-front airflow.

**Table 2: Accessories List**

Accessories	
Power supplies*	Aruba 8325 650W 100-240VAC FB PSU (JL632A) Aruba 8325 650W 100-240VAC BF PSU (JL633A) Aruba 8325 850W 48VDC FB PSU (JL861A) Aruba 8325 850W 48VDC BF PSU (JL862A)
Fan assemblies*	Aruba 8325-48Y8C Front-to-Back Fan (JL628A) Aruba 8325-48Y8C Back-to-Front Fan (JL629A) Aruba 8325-32C Front-to-Back Fan (JL630A) Aruba 8325-32C Back-to-Front Fan (JL631A)
Chassis	Aruba 8325-48Y8C 48p 25G 8p 100G Swch (JL635A) Aruba 8325-32C 32p 100G Swch (JL636A)
Rack mount kits (Not included. Ordered separately.)	Aruba X472 2-Post Rack Kit (JL482B, JL482C) Aruba X474 4-Post Rack Kit (JL483B, JL483C)
* Field replaceable units (FRUs).	

This chapter describes these switches with the following information:

**Front of switches:**

- Network ports
- Console port
- Out-of-band management (OOBM)
- LEDs
- Reset button

**Back of switches:**

- Power supplies and connectors
- Fan assemblies
- LED indicators for fan assemblies and power supplies

**Switch features:**

- Hardware features
- Software features
- Management software

## Front of the Switch

This chapter provides information about the components on the front of the switch.

### 8325-48Y8C JL624A, JL625A, JL857A, and JL858A Switches

**Figure 1** Front of the HPE Aruba Networking 8325-48Y8C (JL624A, JL625A, JL857A, and JL858A) Switch

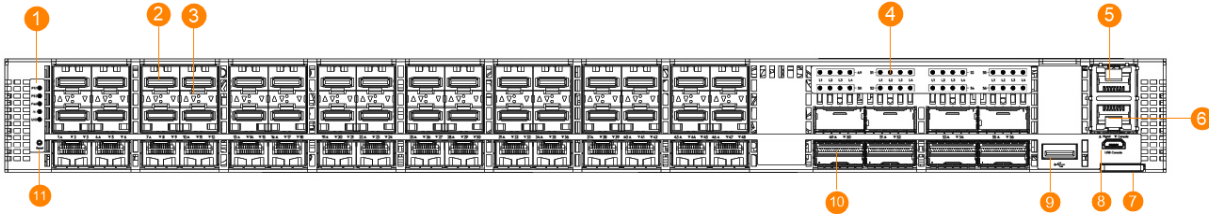
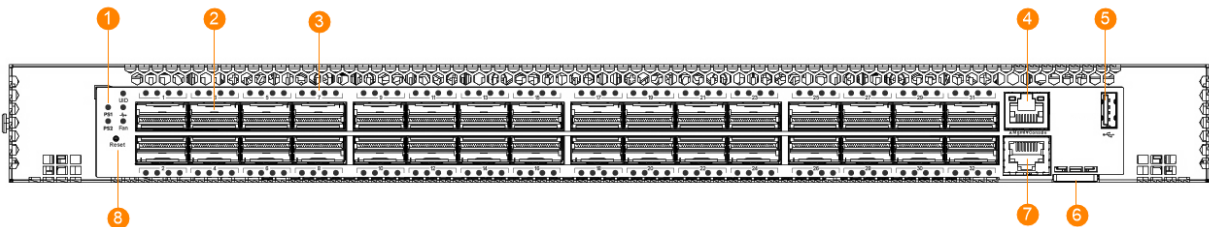

**Table 3:** Front of the HPE Aruba Networking 8325-48Y8C (JL624A, JL625A, JL857A, and JL858A) Switch

Label	Description
1	Power Supply 1 and 2 (PS1/PS2), Fan, Global Status, and Unit Identification LEDs
2	SFP28 ports (these ports support SFP/SFP+/SFP28 transceivers)
3	SFP28 port LEDs. For port LED details, see <a href="#">Port LEDs on the Front of the Switch</a> .
4	QSFP28 port LEDs The first port lane LED (far left) acts as the main port LED in each group of four. The remaining three LEDs are for port lanes 2, 3, and 4.
5	RJ45 10/100/1000 Base-T Out-of-Band Management (OOBM) Port
6	RJ45 serial console port
7	Switch product label. Pull the tab out to view the product label information.
8	Micro-USB serial console port
9	USB-A Port for file management and HPE Aruba Networking Accessories
10	QSFP28 ports (these ports support QSFP+ and QSFP28 transceivers)
11	Reset button

### 8325-32C JL626A, JL627A, JL859A, and JL860A Switches

**Figure 2** Front of the HPE Aruba Networking 8325-32C (JL626A, JL627A, JL859A, and JL860A) Switch



**Table 4:** Front of the HPE Aruba Networking 8325-32C (JL626A, JL627A, JL859A, and JL860A) Switch

Label	Description
1	Power Supply 1 and 2 (PS1/PS2), Unit Identification, Global Status, and Fan LEDs
2	QSFP28 ports (these ports support QSFP+ and QSFP28 transceivers)
3	QSFP28 port LEDs The first port lane LED (far left) acts as the main port LED in each group of four. The remaining three LEDs are for port lanes 2, 3, and 4.
4	RJ45 10/100/1000 Base-T Out-of-Band Management (OOBM) Port
5	USB-A Port for file management and HPE Aruba Networking Accessories
6	Switch product label. Pull the tab out to view the product label information.
7	RJ45 serial console port
8	Reset button

## Network Ports

**Table 5:** Network Ports

Product number	Model name	SFP28 ports <sup>1, 3</sup>	QSFP28 ports <sup>2</sup>
JL624A	Aruba 8325-48Y8C FB 6 F 2 PS Bdl	48	8
JL625A	Aruba 8325-48Y8C BF 6 F 2 PS Bdl		
JL857A	Aruba 8325-48Y8C FB 6 F 2 PS DC Bdl		
JL858A	Aruba 8325-48Y8C BF 6 F 2 PS DC Bdl		
JL626A	Aruba 8325-32C FB 6 F 2 PS Bdl	-	32
JL627A	Aruba 8325-32C BF 6 F 2 PS Bdl		
JL859A	Aruba 8325-32C FB 6 F 2 DC Bdl		
JL860A	Aruba 8325-32C BF 6 F 2 DC Bdl		

<sup>1</sup>SFP28 ports support 1G SFP, 10G SFP+, and 25G SFP28 transceivers.  
<sup>2</sup>QSFP28 ports support 40G QSFP+ and 100G QSFP28 transceivers.  
<sup>3</sup>For information on supported speeds, refer to [Interface-Group Operation](#).

This product also supports optional network connectivity:

**Table 6: Optional Network Connectivity, Speeds, and Technologies**

Speed	Technology	Cabling	Transceiver form-factor and connector <sup>1</sup>				
			SFP (mini-GBIC) Connector	SFP+ Connector	SFP28 Connector	QSFP+ Connector	QSFP28 Connector
1 Gbps	1-Gig T2	Copper (twisted-pair)	-	-	-	-	-
	1-Gig SX	Fiber (multimode)	LC	-	-	-	-
	1-Gig LX	Fiber (multimode or single mode)	LC	-	-	-	-
	1-Gig LH	Fiber (single mode)	LC	-	-	-	-
10 Gbps	10-Gig Direct Attach	Copper (twinaxial)	-	-	-	-	-
	10-Gig AOC	Fiber (multimode)	-	-	-	-	-
	10-Gig BT <sup>3, 4</sup>	Copper (twisted-pair) <sup>5</sup>	-	-	-	-	-
	10-Gig SR	Fiber (multimode)	-	LC <sup>6</sup>	-	-	-
	10-Gig LR	Fiber (single mode)	-	LC	-	-	-
	10-Gig ER	Fiber (single mode)	-	LC	-	-	-
25 Gbps	25-Gig Direct Attach	Copper (twinaxial)	-	-	-	-	-
	25-Gig AOC	Fiber (multimode)	-	-	-	-	-

Speed	Technology	Cabling	Transceiver form-factor and connector <sup>1</sup>				
			SFP (mini-GBIC) Connector	SFP+ Connector	SFP28 Connector	QSFP+ Connector	QSFP28 Connector
	25-Gig SR	Fiber (multimode)	-	-	LC	-	-
	25-Gig eSR	Fiber (multimode)	-	-	LC	-	-
	25-Gig LR	Fiber (single mode)	-	-	LC	-	-
40 Gbps	40-Gig Direct Attach	Copper (twinaxial)	-	-	-	-	-
	40-Gig AOC	Fiber (multimode)	-	-	-	-	-
	40-Gig SR4	Fiber (multimode)	-	-	-	MPO7	-
	40-Gig ESR4	Fiber (multimode)	-	-	-	MPO	-
	40-Gig LR4	Fiber (single mode)	-	-	-	LC	-
	40-Gig ER4	Fiber (single mode)	-	-	-	LC	-
	40-Gig Bidi	Fiber (single mode)	-	-	-	LC	-
100 Gbps	100-Gig Direct Attach	Copper (twinaxial)	-	-	-	-	-
	100-Gig AOC	Fiber (multimode)	-	-	-	-	-
	100-Gig SR4	Fiber (multimode)	-	-	-	-	MPO

Speed	Technology	Cabling	Transceiver form-factor and connector <sup>1</sup>				
			SFP (mini-GBIC) Connector	SFP+ Connector	SFP28 Connector	QSFP+ Connector	QSFP28 Connector
	100-Gig LR4	Fiber (single mode)	–	–	–	–	LC

**NOTE:**

<sup>1</sup> For supported transceivers, see the Transceiver Guide.

For technical details of cabling and technologies, see [Cabling and Technology Information](#).

<sup>2</sup> RJ45 Cat 5e cable is needed for connecting this transceiver. The max link length specified is 100m.

<sup>3</sup> 10 GBase-T transceiver limited support:

- Only supported in ports 1-2, 4-5, 7-8, 10-11, 13-14, 16-17. Use in any other port generates an **Incompatible interface** error.
- Maximum twelve 10 GBase-T transceivers (both interface-groups 1 & 2 must be set for 10 G operation).

<sup>4</sup> RJ45 shielded Cat 6A cable is needed for connecting this transceiver. The max link length specified is 30m.

<sup>5</sup> CAT6A F/FTP, S/FTP, and SF/FTP are highly recommended in noisy environments. Refer to Aruba Support\_Advisory\_JL563A\_10GBaseT\_APSC-RS20180403-01 for more information.

<sup>6</sup> The Lucent Connector (LC) is a small form factor fiber optic connector.

<sup>7</sup> The Multifiber Push On (MPO) connector is a 12-fiber optical connector.

## Management Ports

The following section provides information about the Console Port, Out-of-band Management (OOBM) Port, and the USB-A port.

### Console Port

The HPE Aruba Networking 8325-48Y8C and 8325-32C switches include an RJ45 serial console port. This port is used to connect a console to the switch by using an RJ45 serial cable (not supplied). A DB9-to-RJ45 console cable can be ordered from HPE: JL448A, HPE Aruba Networking X2C2 RJ45 to DB9 Console Cable.

The 8325-48Y8C switches also include an additional Micro USB serial console port. This port can be used to connect a console to the switch by using a standard Micro USB cable (not supplied). The Micro USB connector has precedence for input. If both cables are plugged in, the console output is echoed to both the RJ45 and the Micro-USB ports, but the input is only accepted from the Micro-USB port.

For more information on the console connection, see [Setup for Initial Configuration](#). The console can be a PC or workstation running a VT-100 terminal emulator, or a VT-100 terminal.

The HPE Aruba Networking CX mobile app and the HPE Aruba Networking USB Bluetooth adapter (separately orderable SKU# S1H23A, no longer shipped with CX switches) enable you to configure your switch from your mobile device. For information about using the HPE Aruba Networking CX mobile app to configure the switch, see the *Fundamentals Guide* for your switch and software release.

### Out-of-band Management (OOBM) Port

This RJ45 port is used to connect a dedicated management network to the switch. To use it, connect an RJ45 network cable to the management port to manage the switch through SSH or Telnet from a remote PC or a UNIX workstation.

To use this port, see the *Fundamentals Guide* for your switch. For more detailed information, refer to the switch software manuals for your switch provided at the HPE Networking Support Portal at <https://networkingsupport.hpe.com/downloads>.

A networked out-of-band connection through the management port allows you to manage data network switches from a physically and logically separate management network.

## USB-A Port

A USB-A port is used for file management, downloading switch software code, or using HPE Aruba Networking accessories. This port uses a USB Type-A connector and complies with all USB protocols and standards.

## Chassis LEDs on the Front of the Switch

- The [Chassis LED Behavior](#) table describes the LEDs on the switch chassis.
- The [Port LED Behavior for the HPE Aruba Networking 8325-48Y8C \(JL624A, JL625A, JL857A, and JL858A\) Switch](#) table describes the switch port LEDs and their different behaviors for the JL624A, JL625A, JL857A, and JL858A switches.
- The [Port LED Behavior for the HPE Aruba Networking 8325-32C \(JL626A, JL627A, JL859A, and JL860A\) Switch](#) table describes the switch port LEDs and their different behaviors for the JL626A, JL627A, JL859A, and JL860A switches.

**Figure 3** Chassis LEDs for the HPE Aruba Networking 8325-48Y8C (JL624A, JL625A, JL857A, and JL858A) Switch

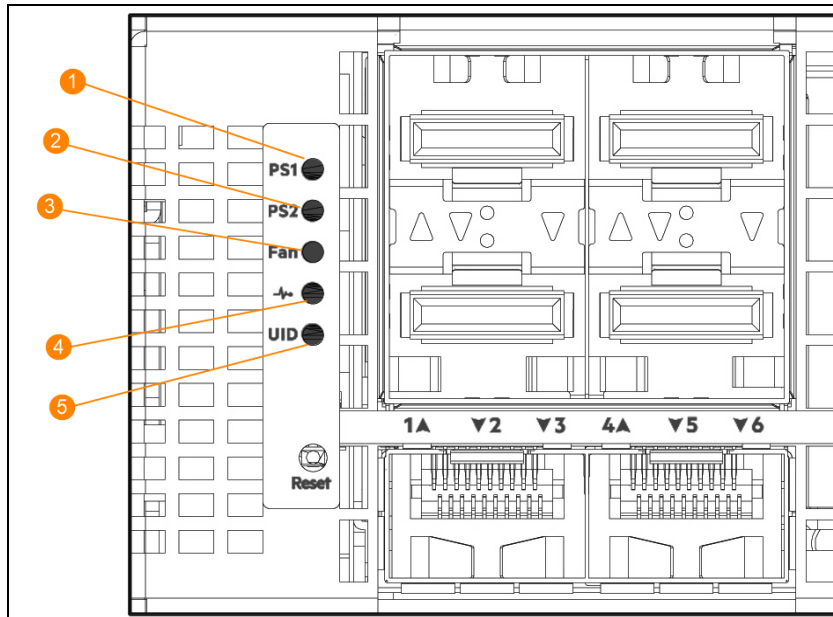

**Table 7:** Chassis LED Labels for the HPE Aruba Networking 8325-48Y8C (JL624A, JL625A, JL857A, and JL858A) Switch

Label	Description
1	Power Supply 1 (PS1) LED
2	Power Supply 2 (PS2) LED
3	Fan LED
4	Global Status LED
5	Unit Identification LED

**Figure 4** Chassis LEDs for the HPE Aruba Networking 8325-32C (JL626A, JL627A, JL859A, and JL860A) Switch

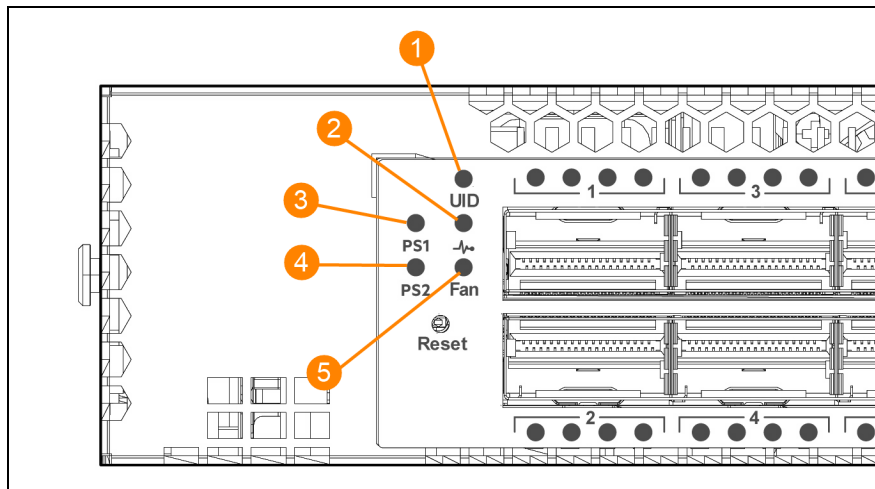

**Table 8:** Chassis LED Labels for the HPE Aruba Networking 8325-32C (JL626A, JL627A, JL859A, and JL860A) Switch

Label	Description
1	Unit Identification LED
2	Global Status LED
3	Power Supply 1 (PS1) LED
4	Power Supply 2 (PS2) LED
5	Fan LED

**Table 9:** Chassis LED Behavior

Chassis LEDs	Function	State	Meaning
PS1/PS2	Power supply status	On green	Power supply is installed and operating with all power supplies and fans installed and no faults are present.
		On amber	Fault detected for installed power supply,

Chassis LEDs	Function	State	Meaning
			or power supply is not receiving power.
		Off	Power supply is not installed.
Fan	Fan tray status	On green	System fans are operating normally.
		On amber	One or more system fans has a fault or the minimum number of fans are not installed.
Global Status	<p>The Global Status LED is used to check the following:</p> <ul style="list-style-type: none"> <li>Internal power status of the switch.</li> <li>Self-test status.</li> <li>Switch/port fault status</li> </ul>	On green	The switch has passed self-test and is powered up normally with all power supplies and fans installed and no faults are present.
		Flashing amber	<ul style="list-style-type: none"> <li>The switch initialization is in progress during bootup.</li> <li>A fault or initialization failure has occurred on the switch, with one of the switch ports, power supplies, or a fan. The port LEDs with the fault will flash simultaneously . LEDs for power supplies and fans with a fault will be on amber.</li> <li>Port-speed mismatch. A transceiver is installed in a port configured for a different speed.</li> </ul>
		Off	The unit is not receiving power.
UID (Unit Identification)	The Unit Identification LED is used to help identify a particular unit in a rack or a collection of products.	On blue or flashing blue	<p>The <code>LED locator on</code> command allows you to turn on the LED.</p> <p>The <code>LED locator flashing</code> command will flash the LED.</p>
		Off	The <code>LED locator off</code> command turns off the LED.

## Port LEDs on the Front of the Switch

**Figure 5** Port LEDs for the HPE Aruba Networking 8325-48Y8C (JL624A, JL625A, JL857A, and JL858A) Switch

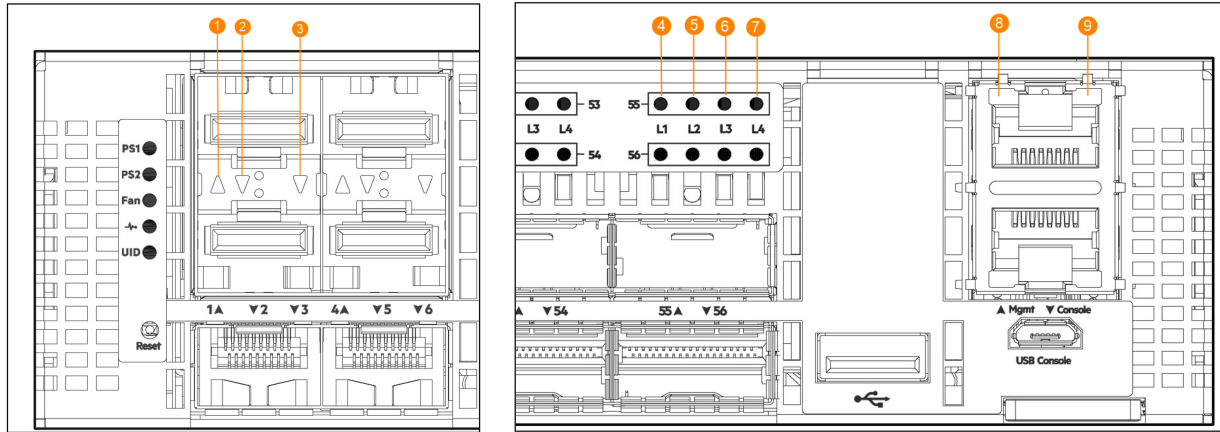

**Table 10:** Port LED Labels for the HPE Aruba Networking 8325-48Y8C (JL624A, JL625A, JL857A, and JL858A) Switch

Label	Description
1	Upper SFP28 port LED
2	Middle SFP28 port LED
3	Lower SFP28 port LED
4	QSFP28 port LED and lane 1 indicator
5	QSFP28 lane 2 LED
6	QSFP28 lane 3 LED
7	QSFP28 lane 4 LED
8	Out-of-band management port Link LED
9	Out-of-band management port Act (activity) LED

**Table 11: Port LED Behavior for the HPE Aruba Networking 8325-48Y8C (JL624A, JL625A, JL857A, and JL858A) Switch**

Chassis LEDs	Function	State	Meaning
SFP28 port LEDs	To display link information for the port.	On green	Shows a valid link at 25/10 Gbps.
		Flashing amber	When the Global Status LED is simultaneously flashing amber, indicates a port-speed mismatch, an incompatible, unsupported, or faulty transceiver, or a port failure.
		Off	Port is disabled, not connected, or not receiving a link beat signal.
QSFP28 port LEDs	To display link and activity information for the port.	On green	Shows a valid link at 100/40 Gbps.
		Flashing amber	When the Global Status LED is simultaneously flashing amber with the Lane 1 LED, it indicates an unsupported or faulty transceiver, or a port failure.
		Off	Port is disabled, not connected, or not receiving a link beat signal.
Management port Link LED	To display link information for the port.	On green	Shows a valid link.
		Off	Port is disabled, not connected, or not receiving a link beat signal.
Management port Act LED	To display activity information for the port.	Flashing yellow	Flashing indicates port activity.

**Figure 6** Port LEDs for the HPE Aruba Networking 8325-32C (JL626A, JL627A, JL859A, and JL860A) Switch

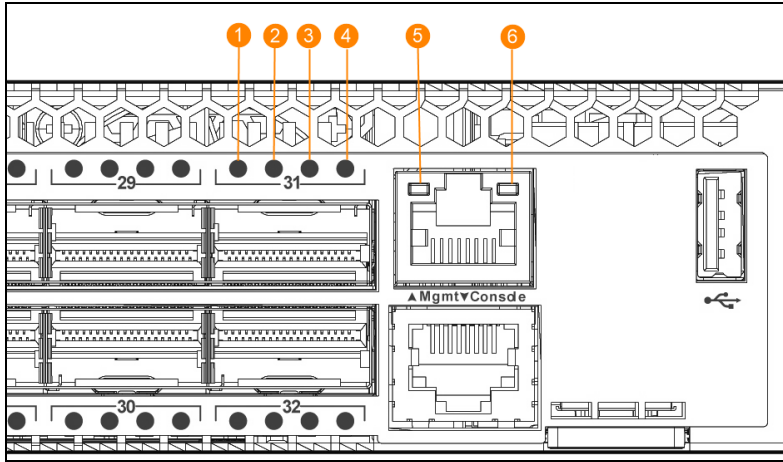

**Table 12:** Port LED Labels for the HPE Aruba Networking 8325-32C (JL626A, JL627A, JL859A, and JL860A) Switch

Label	Description
1	QSFP28 port LED and lane 1 indicator
2	QSFP28 lane 2 LED
3	QSFP28 lane 3 LED
4	QSFP28 lane 4 LED
5	Unused
6	Out-of-band management port Link and Activity LED

**Table 13:** Port LED Behavior for the HPE Aruba Networking 8325-32C (JL626A, JL627A, JL859A, and JL860A) Switch

Chassis LEDs	Function	State	Meaning
QSFP28 port LEDs	To display link information for the port.	On green	Shows a valid link at 100/40 Gbps.
		Flashing amber	When the Global Status LED is simultaneously flashing amber with the leftmost LED, it indicates an unsupported or faulty transceiver, or a port failure.
		Off	Port is disabled, not connected, or not receiving a link beat signal.
Management port Link LED	To display link information for the port.	On green	Shows a valid link.
		Off	Port is disabled, not connected, or not receiving a link beat signal.
Management port Act LED	To display activity information for the port.	Flashing green	Flashing indicates port activity.

## Reset Button

The Reset button is recessed from the front panel (to protect it from being pushed accidentally) and is accessible through a small hole on the front panel. Use a pointed object, such as an unbent paper clip, to push the button.

The Reset button is used as follows:

**Table 14:** Reset Button

To accomplish this:	Do this:	This will happen:
Soft reset	Press and release the Reset button	The switch operating system is cleared gracefully (such as data transfer completion, and temporary error conditions are cleared), and then reboots.
The Reset button is provided for your convenience. If you are concerned about switch security, make sure that the switch is installed in a secure location — such as a locked wiring closet.		

## Switch Product Label

The switch product label is an HPE Aruba Networking Orange-colored tab on the bottom right side of the switch's front panel. Pull the tab out to view the product label information.

The product label information includes the part number, model number, serial number, and MAC address. The information and bar codes are on two labels affixed to the top and bottom of the product label tab.

**Figure 7** HPE Aruba Networking 8325 Switch Product Label

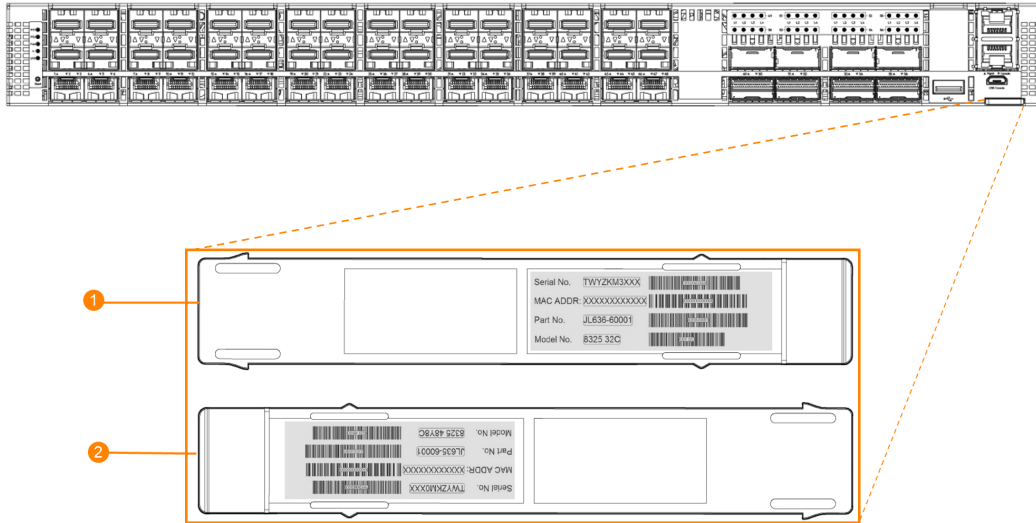

**Table 15:** HPE Aruba Networking 8325 Switch Product Label

Label	Description
1	Product label top side. Information includes the serial number and MAC address.
2	Product label bottom side. Information includes the part number and model number.

## Back of the Switch

The back of the switch includes two power supply units and six fan assemblies.

**Figure 8** Back of the HPE Aruba Networking 8325-48Y8C (JL624A, JL625A, JL857A, and JL858A) Switch

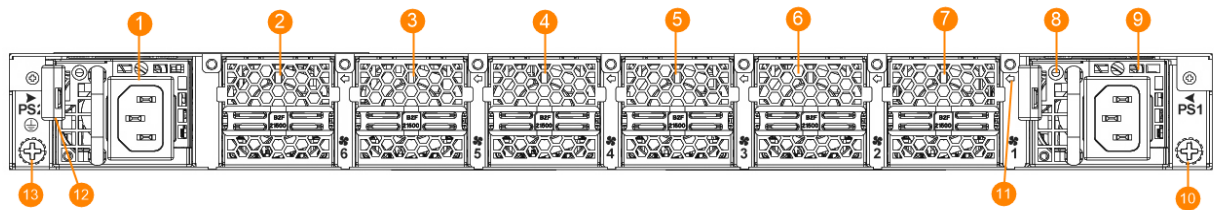

**Table 16:** Back of the HPE Aruba Networking 8325-48Y8C (JL624A, JL625A, JL857A, and JL858A) Switch Labels and Descriptions

Label	Description
1	Power supply 2
2	Fan assembly 6
3	Fan assembly 5
4	Fan assembly 4
5	Fan assembly 3
6	Fan assembly 2
7	Fan assembly 1
8	Power supply status LED
9	Power supply 1
10	Ground lug
11	Fan assembly status LED
12	Color-coded power supply release latch Red—Front-to-back air flow Blue—Back-to-front air flow
13	Ground lug

**Figure 9** Back of the HPE Aruba Networking 8325-32C (JL626A, JL627A, JL859A, and JL860A) Switch

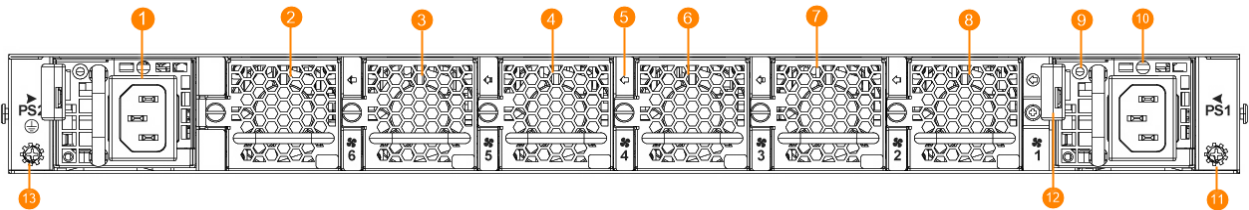

**Table 17:** Back of the HPE Aruba Networking 8325-32C (JL626A, JL627A, JL859A, and JL860A) Switch Labels and Descriptions

Label	Description
1	Power supply 2 <sup>1</sup>
2	Fan assembly 6
3	Fan assembly 5
4	Fan assembly 4
5	Fan assembly status LED
6	Fan assembly 3
7	Fan assembly 2
8	Fan assembly 1
9	Power supply status LED
10	Power supply 1 <sup>1</sup>
11	Ground lug
12	Color-coded power supply release latch Red—Front-to-back air flow Blue—Back-to-front air flow
13	Ground lug
<sup>1</sup> Color-coded power supply release latch: red = front-to-back air flow; blue = back-to-front air flow.	

## Power Supplies

The HPE Aruba Networking 8325 switch does not have a power switch. It is powered on when at least one installed power supply is connected to an active power source. The AC power supplies automatically adjust to any voltage between 100-127 and 200-240 volts and either 50 or 60 Hz. The DC power supplies automatically adjust to any voltage between -36 and -72 volts. There are no voltage range settings required.





---

Never insert or remove a power supply while the power cord is connected. Verify that the cord has been disconnected from the power supply before installation or removal.

---

The HPE Aruba Networking 8325 switch power supplies adapt electrical power for use with the switch. The chassis has two slots that can hold individual power supplies to support load sharing, redundancy, and fault tolerance. Two 650W AC and two 850W DC color-coded power supplies are available for use with HPE Aruba Networking 8325 switches. A red release latch indicates an FB cooling air flow. A blue release latch indicates a BF cooling air flow.

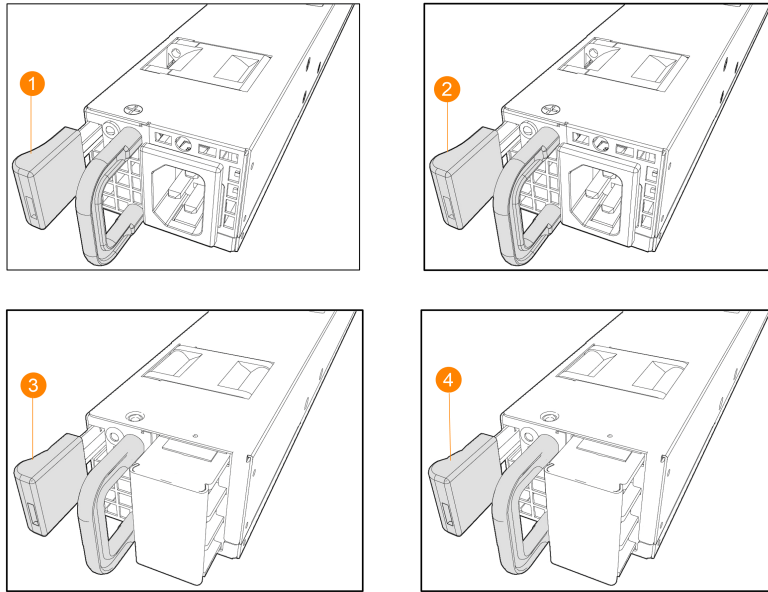
**Figure 10** HPE Aruba Networking 8325 Power Supplies



**Table 18:** HPE Aruba Networking 8325 Power Supplies

Label	Description
1	Aruba 8325 650W 100-240VAC FB PSU (JL632A), red latch
2	Aruba 8325 650W 100-240VAC BF PSU (JL633A), blue latch
3	Aruba 8325 850W 48VDC FB PSU (JL861A), red latch
4	Aruba 8325 850W 48VDC BF PSU (JL862A), blue latch

The HPE Aruba Networking 8325 switch is shipped with two hot-swappable, field-replaceable, AC or DC power supplies. Each AC power supply has a country-specific power cord for connection to an AC power outlet. Each DC power supply uses a DC power cable (5400-3519 or equivalent 8 AWG cable) for connection to a DC power source. The switch can operate with one active power supply.

## Power Supply Status LED

The following table describes the behavior of the power supply LED.

**Table 19:** Power Supply LED Behavior

Power Supply LED	Function	State	Meaning
Status LED	To display power supply status.	On green	The power supply is operating normally.
		Flashing green or on amber	The power supply is experiencing a fault, or has power but is not installed in the switch unit.
		Off	Power is not connected to the power supply or, if power is connected, the power supply is in protection mode due to a voltage, current, thermal, or short-circuit condition.

## Load Sharing

Load sharing occurs when two power supplies are installed in the switch and turned on. Load sharing divides the total power load of the switch among both power supplies.

## Mixing AC and DC Power Supplies

Installing AC and DC power supplies together in the switch is not supported. The installed power supplies must be of the same type and same airflow direction.

## Redundancy

With power redundancy, the HPE Aruba Networking 8325 switch can continue normal operation even when one power supply fails or is powered off. When two power supplies are installed, if one becomes unavailable (fails, or is powered off or removed) the remaining power supply provides full power for the device.

## Hot Swapping

Hot swapping allows you to replace one failed power supply while the other provides full power. This makes it unnecessary to shut down the switch during the replacement procedure.



---

Never insert or remove a power supply while the power cord is connected. Verify that the cord has been disconnected from the power supply before installation or removal.

---

## Fan Assemblies

The HPE Aruba Networking 8325 switch is equipped with six field-replaceable, hot-swappable fan assemblies. Each fan assembly features individual fans that pull air through the chassis from front to back (FB) or from back to front (BF).



- 
- Fans and power supplies installed in a given HPE Aruba Networking 8325 switch must have the same cooling air flow direction (FB or BF). Air flow direction in an HPE Aruba Networking 8325 switch is not controlled by software. To change the air flow direction, replace the power supplies and fans with power and fan units supporting the air flow direction you want. See [HPE Aruba Networking 8325 Power Supplies](#) and [HPE Aruba Networking 8325 Fan Assemblies](#).
  - A minimum of five fan assemblies is required for operation. The system will automatically shutdown if overheating is detected. If five or fewer fan assemblies are installed, the Fan LED will be on amber and the Global Status LED will flash amber to indicate a fan fault may exist.
  - System airflow direction (FB or BF) is configured automatically at system initialization and cannot be reconfigured by the user. System airflow direction is determined by the power supply type installed in PS1 at initialization time (or PS2 if PS1 is absent or non-operational). Any Fan assembly or Power supply of conflicting airflow type will be disabled by the system. Ensure only matching Fan assemblies and power supplies are used at any given runtime.
- 

Fan models are color-coded for FB or BF cooling air flow. The color codes are as follows:

- Red handle indicates a front-to-back (FB) cooling air flow.
- Blue handle indicates a back-to-front (BF) cooling air flow.

See the following table for fan usage.

**Table 20:** HPE Aruba Networking 8325 Fan Assemblies

Fan assembly	Color code	48-port switches	32-port switches
Aruba 8325-48Y8C Front-to-Back Fan (JL628A)	Red	Yes	No
Aruba 8325-48Y8C Back-to-Front Fan (JL629A)	Blue	Yes	No
Aruba 8325-32C Front-to-Back Fan (JL630A)	Red	No	Yes

Fan assembly	Color code	48-port switches	32-port switches
Aruba 8325-32C Back-to-Front Fan (JL631A)	Blue	No	Yes

**Figure 11** HPE Aruba Networking 8325 Fan Assemblies

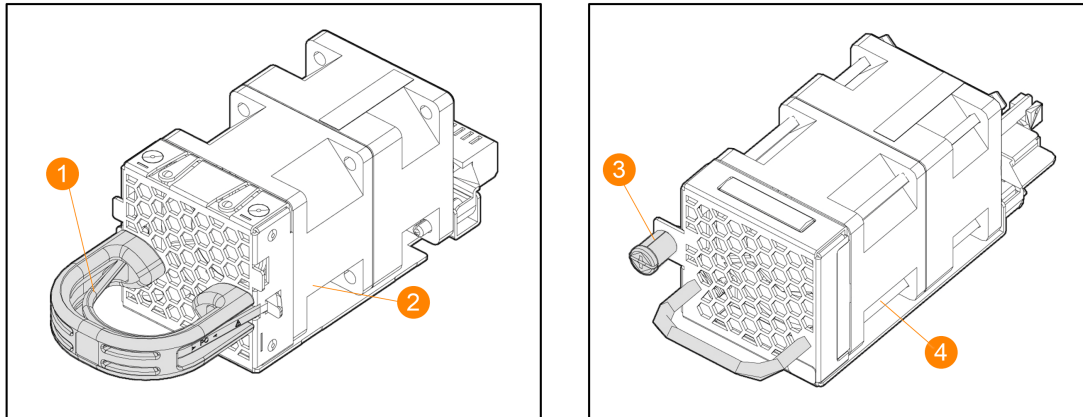

**Table 21:** HPE Aruba Networking 8325 Fan Assemblies

Label	Description
1	Fan release latch
2	Aruba 8325-48Y8C Front-to-Back Fan (JL628A)
3	Fan release screw
4	Aruba 8325-32C Back-to-Front Fan (JL631A)

The switch can tolerate the failure of a single fan assembly while maintaining a safe operating temperature. The switch may continue to operate with one failed fan assembly. If the switch reaches an overtemp condition, the switch will shut down. For best operation, the failed fan assembly should be replaced as soon as possible.

If one or more of the fan assemblies have failed, the front-panel Fan LED will be on amber and the failed fan assembly LEDs will be on red.

If multiple fans have failed, the switch should be immediately powered off and the fan assemblies replaced.



---

Fans designed for the 48-port HPE Aruba Networking 8325 switches are not compatible with 32-port HPE Aruba Networking 8325 switches and vice versa.

---



---

The HPE Aruba Networking 8325 switch is not compatible with fan assemblies from other HPE Aruba Networking hardware platforms.

---

## Fan Assembly Status LED

The following table describes the behavior of the Fan Assembly LED.

**Table 22:** Fan Assembly LED Behavior

Fan assembly LED	Function	State	Meaning
Status LED	To display fan assembly status.	On green	The fan assembly is operating normally.
		On red	The fan assembly has been disabled by the system due to system airflow direction conflict, has failed or is missing.

Use the `show environment fan` command for fan status information. (See the *HPE Aruba Networking 8325 Fundamentals Guide* for ArubaOS-CX 10.02 or later at <https://networkingsupport.hpe.com/downloads>.)

## Switch Features

The features of the HPE Aruba Networking 8325 switches include the following:

- Combinations of fixed QSFP28 and SFP28 ports, as described under [Network Ports](#).
- For secure environment, all ports are disabled by default.
- The option to have one or two power supplies: A second power supply supports redundant system power. If one of the power supplies fails, the second power supply immediately provides the power necessary to keep the switch running.
- The QSFP28 and SFP28 ports always operate at full duplex.
- Easy management of the switch through several available interfaces. The following are the available interfaces:

- **Command line interface**—A full featured, easy to use, VT-100 terminal interface for out-of-band switch management.
- **Web browser interface**—An easy to use built-in graphical interface that can be accessed from common web browsers.
- Support for the Spanning Tree Protocol to eliminate network loops.
- Support for up to 4094 IEEE 802.1Q-compliant VLANs so you can divide the attached end nodes into logical groupings that fit your business needs.
- Support for many advanced features to enhance network performance.
- To download product updates, go to either of the following portals:
  - Hewlett Packard Enterprise Support Center **Get connected with updates from HPE** page: [www.hpe.com/support/e-updates](http://www.hpe.com/support/e-updates).
  - HPE Networking Support Portal: <https://networkingsupport.hpe.com/downloads>
  - To view and update your entitlements, and to link your contracts and warranties with your profile, go to the **Service Management** tab on the HPE Networking Support Portal at <https://networkingsupport.hpe.com>.

This chapter shows how to install the switch. The HPE Aruba Networking 8325 switch requires you to order a rack mount kit that includes the brackets for mounting the switch in a standard 19-inch telco rack, or in an equipment cabinet. For mounting options, see [Mount the Switch](#) or contact your HPE Aruba Networking representative or HPE Aruba Networking-authorized reseller.

### Included Parts

The HPE Aruba Networking 8325 switch is shipped with the following components:

- Documentation kit
- USB Bluetooth adapter enables you to configure your switch from your mobile device. Requires the Aruba CX Mobile App. (Adapter is attached to a card in the documentation kit). For information about using the Aruba CX mobile app to configure the switch, see the Fundamentals Guide for your switch and software release.
- Units with AC power supply and power cord can be ordered through HPE Aruba Networking purchasing systems using the part number or J-number (SKU) listed below.

Argentina	8121-0729 J9891A	Israel	8121-1004 J9899A
Australia/New Zealand	8121-0837 J9883A	Japan	8121-1143 J9893A
Brazil	8121-1071 J9894A	Switzerland	8121-0738 J9898A
Chile	8121-0735 J9886A	South Africa	8121-0737 J9897A
China	8121-0943 J9890A	Taiwan	8121-0964 J9887A
Continental Europe/South Korea	8121-0731 J9885A	Philippines/Thailand	8121-0734 J9895A
Denmark	8121-0733 J9888A	UK/Hong Kong/Singapore/Malaysia	8121-0739 J9884A
India	8121-0564 J9892A	US/Canada/Mexico	8121-1141 J9896A
NA Hi-Voltage (non-locking) C13 to NEMA 6-20	8120-3396 J9936A	PDU NA/Japan/TW PDU Rest of World PDU India-only	8121-1091 J9943A 8121-1094 J9944A P09371-001 JL671A
NA Hi-Voltage (locking) C15 to NEMA L6-20	8121-0941 J9955A*		
* Ordered separately from the switch. To order a switch that will use a J9955A power cord, use the <b>no power cord</b> option, #AC3, and specify the J9955A power cord as a separate line item in the order.			

- Units with DC power supply and DC power cable (5400-3519).

## Japan Power Cord Warning

製品には、同梱された電源コードをお使い下さい。  
同梱された電源コードは、他の製品では使用出来ません。

## Parts not Included



---

If you have not already done so, order an HPE Aruba Networking rack mount kit for use with your 8325 switch.

---

Rack mounting your HPE Aruba Networking 8325 switch is supported using the following rack-mount kits:

- JL482B, JL482C, Aruba X472 2-Post Rack Kit (Not included. Ordered separately.)
- JL483B, JL483C, Aruba X474 4-Post Rack Kit (Not included. Ordered separately.)

A DB9-to-RJ45 console cable can be ordered from HPE: JL448A, HPE Aruba Networking X2C2 RJ45 to DB9 Console Cable.

## Installation Procedures

### Summary

To install your switch, complete the following steps:

1. [Prepare the Installation Site](#): Ensure the physical environment into which you will be installing the switch is properly prepared, including having the correct network cabling ready to connect to the switch and having an appropriate location for the switch. See [Installation Precautions](#) for some guidelines on avoiding personal injury or product damage when installing your switch.
2. [Install Power Supplies](#): Install power supplies if they are not already installed.
3. [Install Fan Assemblies](#): Install fan assemblies if they are not already installed.
4. [Power-on the Switch and Check the LEDs](#): Power-on the switch and check the LEDs for proper switch operation.
5. [Power off the Switch](#): Remove the power cord from the switch and from the power source.
6. [Mount the Switch](#): The switch can be mounted in a 19-inch telco rack or in an equipment cabinet.
7. (Optional) [Install Transceivers](#): The switch has slots for installing SFP+/SFP28 and QSFP+/QSFP28 transceivers. Depending on where you install the switch, it may be easier to install the transceivers first. Transceivers can be hot swapped—they can be installed or removed while the switch is powered on.
8. [Connect the Switch to a Power Source](#): Once the switch is mounted, plug it into the main power source.
9. [Setup for Initial Configuration](#): Connect a management console to the switch. You may want to modify the switch's configuration, so it can be managed using a Web browser or through an SSH or Telnet session. Configuration changes can be made by using a console cable to connect a PC to

the switch's console port, or use a USB Bluetooth adapter (separately orderable SKU# S1H23A, no longer shipped with CX switches), to configure the switch from your mobile device.

10. [Connect the Network Cables](#): Using the appropriate network cables, connect the network devices to the switch ports.

At this point, your switch is fully installed. See the rest of this chapter if you need more detailed information on any of these installation steps.

## Installation Precautions

To avoid personal injury or product damage when installing your switch, read the installation precautions and guidelines below.



- 
- Do not mount the switch on a wall, on or under a table, or on or under any other horizontal surface.
  - Mount devices installed in a rack or cabinet as low as possible. Put the heaviest devices at the bottom and progressively lighter devices installed above.
  - To prevent the rack or cabinet from becoming unstable and/or falling over, ensure that it is adequately secured.
-

- 
- Ensure that the power source circuits are properly grounded. Then connect the switch to the power source by using the power cord supplied with the switch.
  - If your installation requires a different power cord than the one supplied with the switch and power supply, be sure that the cord is adequately sized for the switch's current requirements. In addition, be sure to use a power cord displaying the mark of the safety agency that defines the regulations for power cords in your country. The mark is your assurance that the power cord can be used safely with the switch and power supply.
  - When installing the switch, the AC outlet should be near the switch and be easily accessible in case the switch must be powered off.
  - When powered by a DC power supply, the installation shall provide a readily accessible two-pole disconnect device in the fixed installation.
  - Do not install the switch in an environment where the operating ambient temperature exceeds its specification. (See the [Environmental](#) information).
  - Ensure that the switch does not overload the power circuits, wiring, and over-current protection. To determine the possibility of overloading the supply circuits, add the ampere ratings of all devices installed on the same circuit as the switch. Then compare the total with the rating limit for the circuit. The maximum ampere ratings are usually printed on the devices near the AC power connectors.
  - Ensure that the air flow around the switch is not restricted. Leave at least 3 inches (7.6 cm) for cooling. For air flow direction, determine whether your switch has front-to-back or back-to-front fans and power supply units.
  - All power supplies and fan assemblies installed in an 8325 switch must have the same cooling air flow direction (FB or BF).
  - Never insert or remove a power supply while the power cord is connected. Verify that the cord has been disconnected from the power supply before installation or removal.
  - When powered by a DC power supply, the switch must be installed in a restricted access location. Only trained and qualified personnel should be allowed to install, replace, or service this equipment.
  - For switches with DC power supplies, disconnect DC power from the power supply BEFORE installing or removing the power supply. The power supply must NOT be connected to DC power while it is being installed or removed. The switch power supplies are hot-swappable; that is, a power supply that is disconnected from the power source can be installed or removed while the switch is receiving power from another power supply installed in the other power supply slot.
  - Always switch input power OFF before connecting and disconnecting the DC input to the unit. If not turned off, there is a risk of injury or severe damage.
  - When powered by a DC power supply, the product relies upon the installation to provide short-circuit (over-current) protection. Ensure that the protective device is not greater than 20A for non-PoE switches and not greater than 40A for PoE switches when using DC power.
  - When installing DC power cords, ensure that appropriate strain relief and cable routing is in place to prevent damage or loosening of connections during use.
  - This power supply is declared to be supplied from earthed DC source. As extensive use, this power supply shall be separated from primary circuits/building mains by double/reinforced insulation.
  - If a power supply must be removed and then reinstalled, wait at least 5 seconds before reinstallation. Otherwise, damage to the switch may occur.
  - The power supply needs this time to bleed off any retained power.
- 



CAUTION

## Prepare the Installation Site

To prepare the installation site, complete the following procedures:

**Cabling Infrastructure:** Ensure that the cabling infrastructure meets the necessary network specifications. See [Cabling and Technology Information](#) for more details.

**Installation Location:** Before installing the switch, plan its location and orientation relative to other devices and equipment as follows:

- In the front of the switch, leave at least 3 inches (7.6 cm) of space for the twisted-pair and fiber-optic cabling.
- In the back of the switch, leave at least 3 inches (7.6 cm) of space for the power cord.
- On the sides of the switch, leave at least 3 inches (7.6 cm) for cooling.

Cooling air flow in HPE Aruba Networking 8325 switches is Front-to-Back (FB) or Back-to-Front (BF), depending on which power supply and fan assembly options are installed. To reverse the cooling air flow direction in an 8325 switch, you must replace the existing power supplies and fan assemblies with power supplies and fan assemblies having the opposite air flow direction. All fans and power supplies installed in an 8325 switch must have the same air flow direction. For specific model information, see [Overview](#).



To avoid personal injury or product damage, review [Installation Precautions](#) before beginning the installation process.

---

## Install Power Supplies

Skip this step if a power supply is already installed in the switch.

If a power supply is not already installed in the switch, install at least one power supply before continuing in this guide. The HPE Aruba Networking 8325 switch uses any of the following power supplies:

- Aruba 8325 650W 100-240VAC FB PSU (JL632A)
- Aruba 8325 650W 100-240VAC BF PSU (JL633A)
- Aruba 8325 850W 48VDC FB PSU (JL861A)
- Aruba 8325 850W 48VDC BF PSU (JL862A)



- A red-colored power supply release lever indicates a Front-to-Back (FB) air flow.
  - A blue-colored power supply release lever indicates a Back-to-Front (BF) air flow.
-

**Figure 12** *Installing a Power Supply*

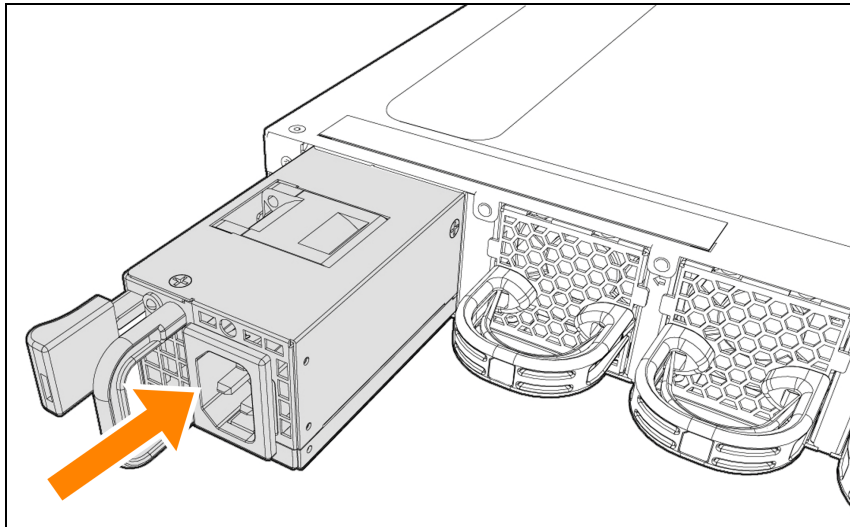

## Install Fan Assemblies

Skip this step if all six fan slots are already populated with fan assemblies.



- The 48-port switches and the 32-port switches use different fan assemblies. Each fan assembly type can only be installed in the correct switch model.
- Ensure that a replacement fan has the same airflow as other fans installed in the switch (FB or BF).
- A red-colored fan handle indicates a Front-to-Back (FB) air flow. A blue-colored fan handle indicates a Back-to-Front (BF) air flow.

To install a fan assembly in any empty fan slot, complete the following steps:

1. Remove the new fan assembly from its packaging, being careful not to touch any of the circuitry on the board.
2. Insert the new fan assembly fully into the slot so that its face plate is flush with the back face of the switch. If the switch is connected to a power source, the fan assembly should immediately start running.
3. For the 32-port switch fan assembly, engage the retaining screw and tighten it. Be sure not to over-tighten the screw.

**Figure 13** *Installing a Fan Assembly*

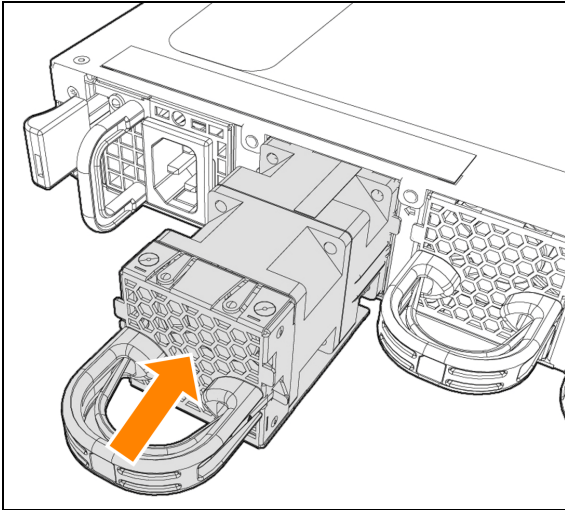

## Power-on the Switch and Check the LEDs

An HPE Aruba Networking 8325 switch does not contain a power on/off switch. It is turned on by connecting a power cord to the switch and to a power source.

### AC Power Supplies

Plug an AC power cord into the power connector on the switch and into an AC power source.

**Figure 14** *Connecting AC Power to the Switch*

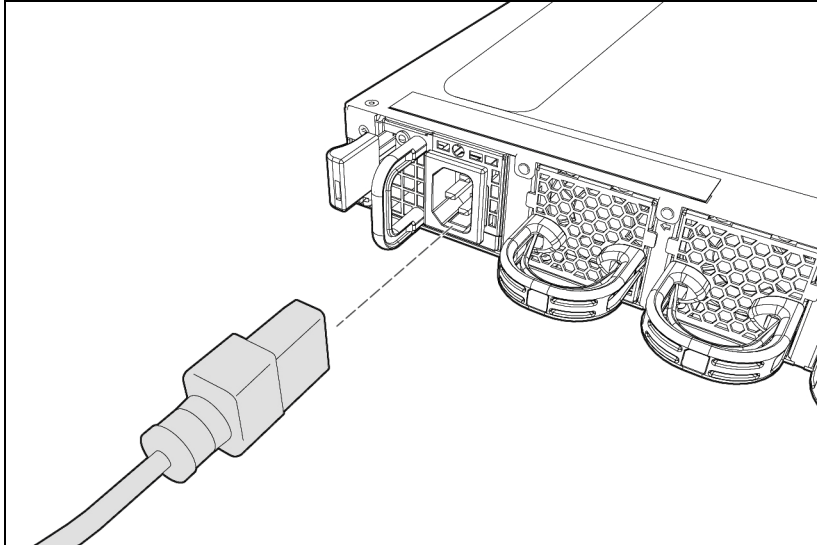

### DC Power Supplies

1. Make sure that the DC power source lines are turned off or disconnected from the DC circuit.
2. Remove the transparent protective cover from the DC connector terminals and set it aside.

**Figure 15** Removing a DC Power Supply Cover

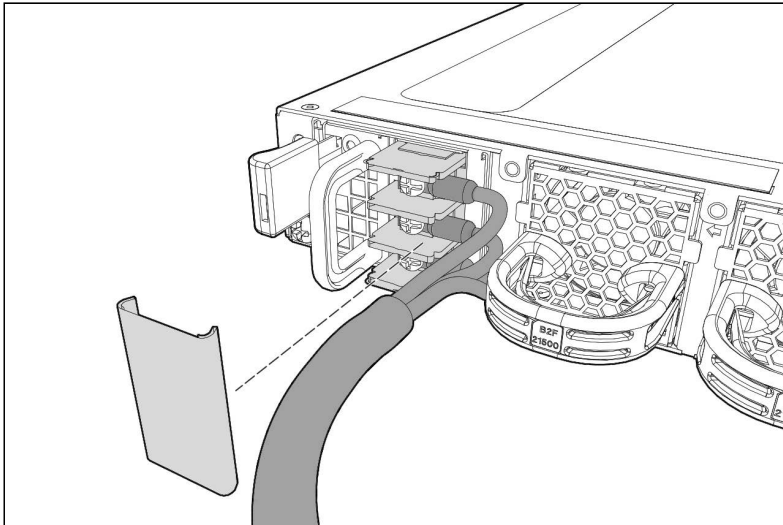

3. Using a DC power cable (5400-3519 or equivalent 8 AWG cable), connect the DC supply Ground, -36 - -72 V, and DC Return wires to the terminals (as marked on the power supply) and tighten the screws to a torque of 6.6 in-lbs.

**Figure 16** Connecting DC Power to the Switch

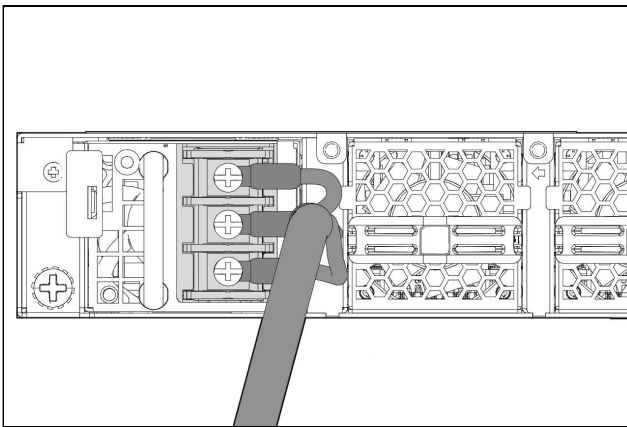

4. Replace the transparent protective cover on the DC connector terminals.
5. Turn on the DC power source lines or reconnect them to the DC circuit.

### Check LEDs for Proper Switch Operation

**Figure 17** Chassis LEDs for the HPE Aruba Networking 8325-48Y8C (JL624A, JL625A, JL857A, and JL858A) Switch

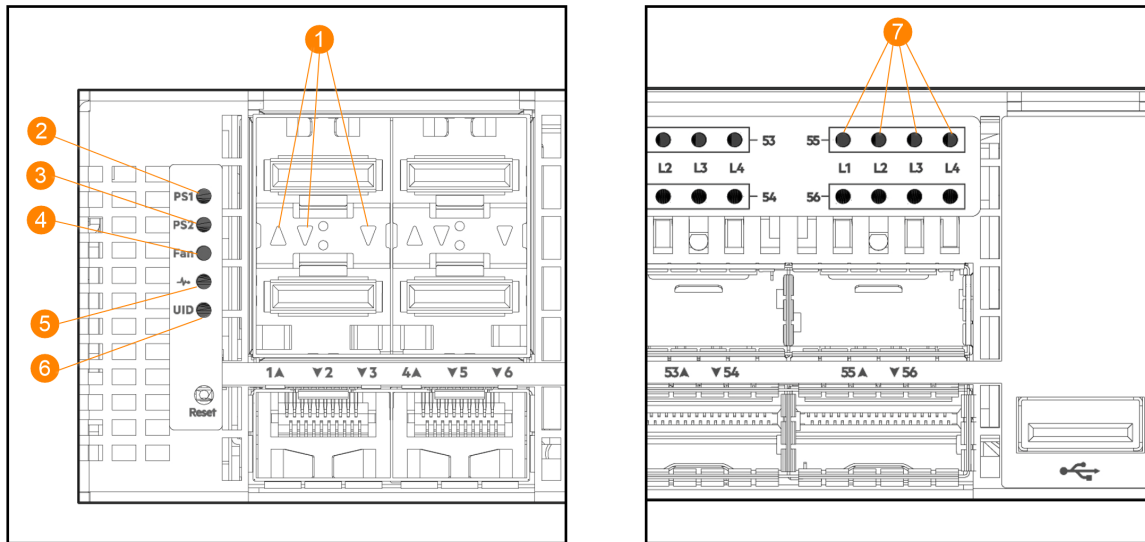

**Table 23:** Chassis LED Labels for the HPE Aruba Networking 8325-48Y8C (JL624A, JL625A, JL857A, and JL858A) Switch

Label	Description
1	<b>SFP28 Port LEDs:</b> Off, unless a network cable is connected and the port is receiving link beat.
2	<b>PS1 LED:</b> Flashes green after power on, unless the power supply is in a fault state, or not receiving power.
3	<b>PS2 LED:</b> Flashes green after power on, unless the power supply is in a fault state, or not receiving power.
4	<b>Fan LED:</b> Flashes green after power on, unless a fan on the back of the unit is in a fault state.
5	<b>Global Status LED:</b> Flashes green after power on, in the default configuration. Flashes amber during bootup.
6	<b>UID LED:</b> Locator or Unit Identification LED. Off after power on.
7	<b>QSFP28 Port LEDs:</b> Off, unless a network cable is connected and the port is receiving link beat.

**Figure 18** Chassis LEDs for the HPE Aruba Networking 8325-32C (JL626A, JL627A, JL859A, and JL860A) Switch

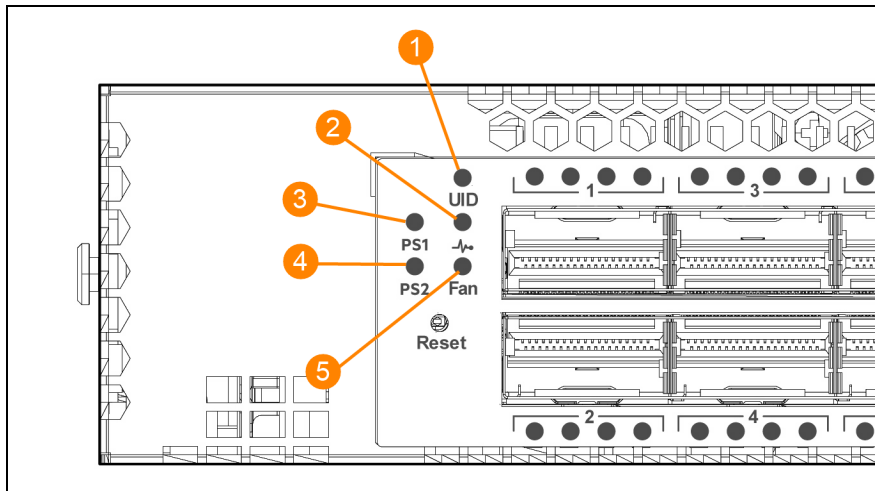

**Table 24:** Chassis LED Labels for the HPE Aruba Networking 8325-32C (JL626A, JL627A, JL859A, and JL860A) Switch

Label	Description
1	<b>UID LED:</b> Locator or Unit Identification LED. Off after power on.
2	<b>Global Status LED:</b> Flashes green after power on, in the default configuration. Flashes amber during bootup.
3	<b>PS1 LED:</b> Flashes green after power on, unless the power supply is in a fault state, or not receiving power.
4	<b>PS2 LED:</b> Flashes green after power on, unless the power supply is in a fault state, or not receiving power.
5	<b>Fan LED:</b> Flashes green after power on, unless a fan on the back of the unit is in a fault state.

## Power off the Switch

Remove the power cord from the switch and from the power source.

## Mount the Switch

This section describes how to mount an HPE Aruba Networking 8325 switch.

### Mounting an HPE Aruba Networking 8325 Switch

The supported mounting options for the HPE Aruba Networking 8325 switch include:

- Two-post rack mount (JL482B, JL482C; sold separately)
- Four-post rack mount (JL483B, JL483C; sold separately)



See [Installation Precautions](#) before mounting your switch.



Airflow and air temperature within an equipment rack can be variable and are dependent on the overall rack configuration. In some configurations, there may be insufficient or recirculating airflow that causes the switch to operate at an elevated temperature. Position and orientation should be considered when configuring the switch within the rack to minimize these effects and maintain compliance with the switch's temperature limits.

## Two-post Rack Mount Option

The switch is designed to be mounted in any EIA-standard 19-inch telco rack or communication equipment cabinet using the HPE Aruba Networking X472 2-Post Rack Kit (JL482B, JL482C; sold separately).

The mounting brackets must only be attached for mid-mounting the switch in a two-post rack. Secure the rack in accordance with the manufacturer's safety guidelines.



For safe operation, please review the mounting precautions in [Installation Precautions](#), before mounting a switch.



- The 12-24 screws supplied with the switch are the correct threading for standard EIA/TIA open 19-inch racks. If installing the switch in an equipment cabinet such as a server cabinet, use the clips and screws that came with the cabinet in place of the 12-24 screws that are supplied with the switch.
- Complete step 1, and plan which four holes you will be using in the cabinet and install all four clips. Then proceed to step 2.

Complete the following steps to mount the switch in a two-post rack:

1. Use a #1 Phillips (cross-head) screwdriver and attach the mounting brackets to the switch with the included eight 6-mm M4 screws. The brackets must only be attached for mid-mounting the switch in a two-post rack. Ensure the holes in the bracket are aligned with the correct holes in the switch, as per the diagram.

**Figure 19** Attaching Two-post Mounting Brackets to the Switch

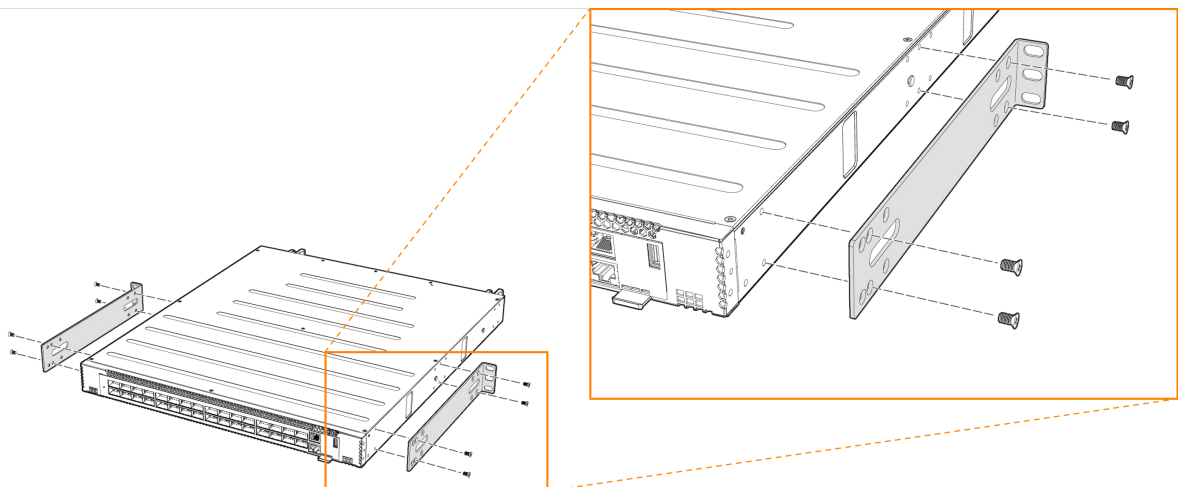



---

For safe, reliable installation, only use the screws provided in the accessory kit to attach the mounting brackets to the switch.

---

2. Hold the switch with attached brackets up to the rack, move it vertically until rack holes line up with the bracket holes, and then insert and tighten the four number 12-24 screws holding the brackets to the rack.

**Figure 20** *Mounting the Switch in a Two-post Rack*

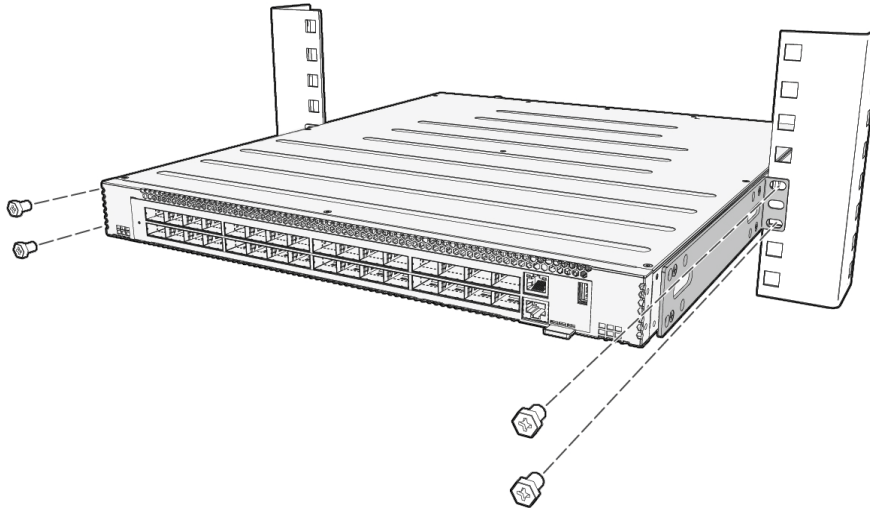

### Four-Post Rack Mount Option

The HPE Aruba Networking 8325 switch can be mounted in four-post racks and cabinets by using the HPE Aruba Networking X474 4-Post Rack Kit (JL483B, JL483C; sold separately). Determine whether you are installing a front-to-back airflow switch or a back-to-front airflow switch, then use the instructions below to attach the mounting brackets and mount the switch.

The JL483B, JL483C HPE Aruba Networking X474 4-Post Rack Kit includes the following items:

- Two front-post brackets
- Two rear-post brackets with adjustable ears
- Twenty 6-mm M4 screws
- Eight 5/8-inch number 12-24 screws
- Two rear bracket ear position-locking screws

The brackets must only be attached for front-flush mounting the switch in a four-post rack. Secure the rack in accordance with the manufacturer's safety guidelines.



---

For safe operation, please read the mounting precautions in [Installation Precautions](#), before mounting a switch.

---



---

The rack rails are intended for ease of installation only, do not use rails to support the switch in any extended position. The switch must be immediately secured with screws after installation.

---



- The 12-24 screws supplied with the four-post rack mount kit are the correct threading for standard EIA/TIA open 19-inch racks. If installing the switch in an equipment cabinet such as a server cabinet, use the clips and screws that came with the cabinet in place of the 12-24 screws that are supplied with the four-post rack mount kit (JL483B, JL483C).
- Complete step 1, and plan which holes you will be using in the cabinet and install all four clips. Then proceed to step 2.

1. Use a #1 Phillips (cross-head) screwdriver and attach the front- and rear-post rack mount brackets to the switch with the included 6-mm M4 screws.

**Figure 21** Attaching Four-post Mounting Brackets to the Switch

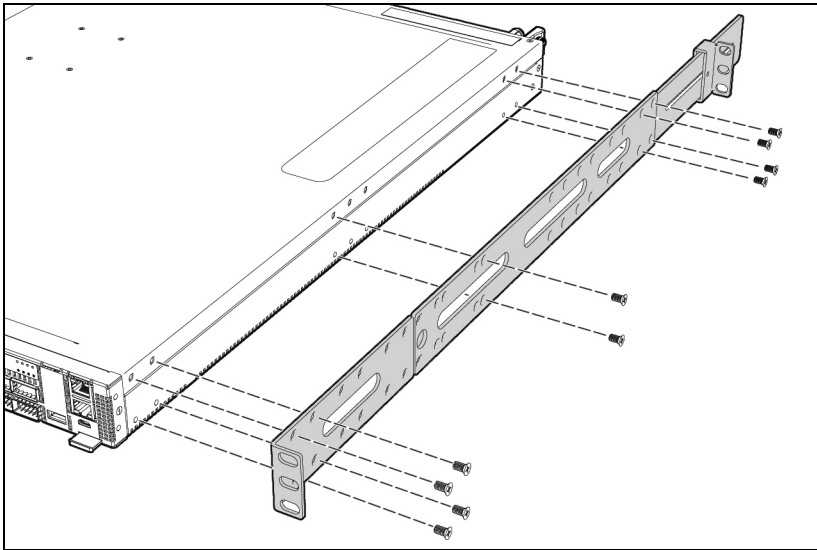

For safe, reliable installation, only use the screws provided in the accessory kit to attach the mounting brackets to the switch.

2. For the rear-post brackets, use an additional two 6-mm M4 screws to secure the bracket at the mid-point on the side of the switch.
3. Hold the switch with attached brackets up to the rack, move it vertically until the rack holes line up with the front-post bracket holes, and then insert and tighten the four number 12-24 screws holding the brackets to the rack.

**Figure 22** *Mounting the Switch in a Four-post Rack*

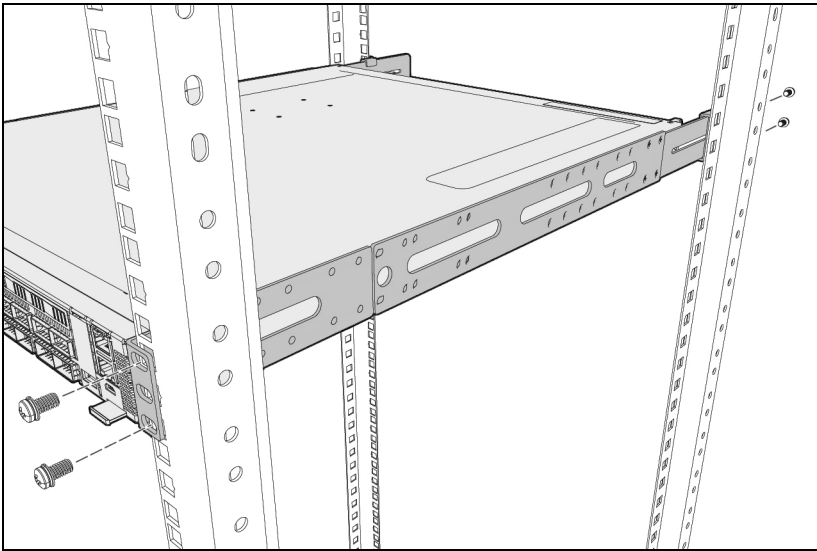

4. Adjust the rear-post bracket ears to fit the depth of the rack.
5. Secure the rear-post brackets to the rack rear posts using four number 12-24 screws.
6. Lock the position of the rear-post bracket ears using the included position-locking screws.

**Figure 23** *Locking the Position of Rear-post Brackets*

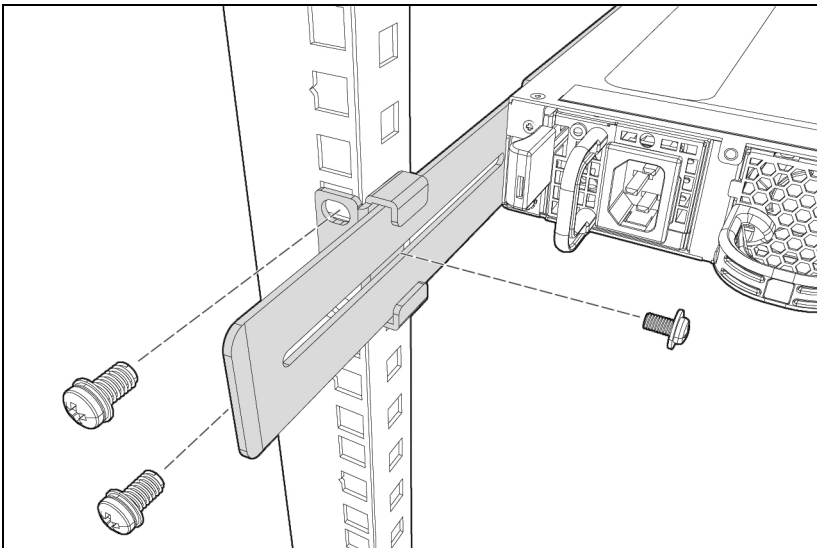

## Install Transceivers

Hold the transceiver by its sides and gently insert it into the switch until it clicks into place. When a transceiver is inserted, the switch will authenticate it. This will typically take 1-3 seconds, with the worst case being 5 seconds.



- The transceivers operate only at full duplex. Half duplex operation is not supported.
- Ensure the network cable is NOT connected when you install or remove a transceiver.
- You can install or remove a transceiver from an SFP28/QSFP28 slot without having to power off the switch.



- Use only supported HPE Aruba Networking transceivers as shown in the ArubaOS-Switch and ArubaOS- CX Transceiver Guide (<https://networkingsupport.hpe.com/downloads>). The use of unsupported transceivers may result in product malfunction.
- The HPE Aruba Networking transceivers are Class 1 Laser devices. Avoid direct eye exposure to the beam coming from the transmit port.
- Use of supported genuine HPE Aruba Networking transceivers is always recommended. Non-HPE Aruba Networking SFP/SFP+/SFP28/QSFP+/QSFP28 transceivers can be used in unsupported transceiver mode, but no support or warranty will be provided. Should you require additional transceivers, contact your HPE Aruba Networking sales representative or an authorized reseller.



Refer to the [Optional Network Connectivity, Speeds, and Technologies](#) table, footnote 3, for ports that support 10 GBase-T transceivers.

**Figure 24** *Installing a Transceiver*

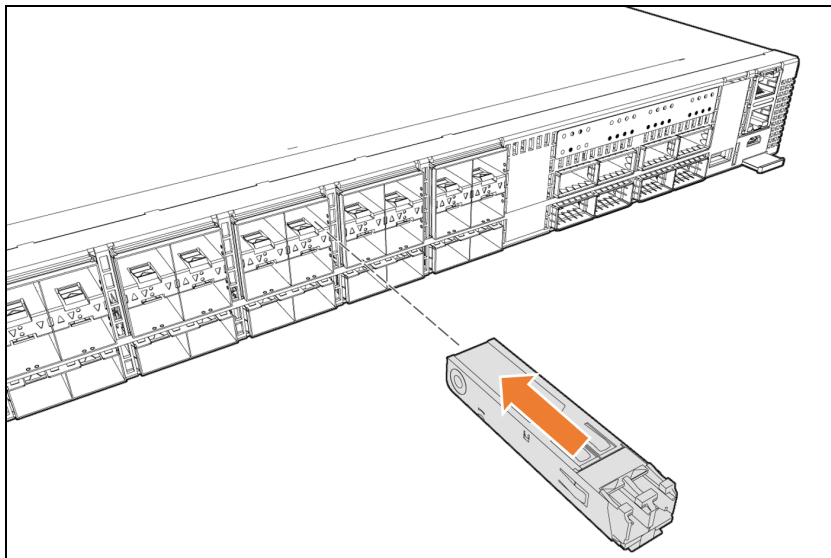

## Removing Transceivers

Depending on the transceiver, it will have either of the three different release mechanisms mentioned below:

- A plastic tab on the bottom of the transceiver.
- A plastic collar around the transceiver.
- A wire bail.

To remove the transceivers that have the plastic tab or plastic collar, push the tab or collar toward the switch until the transceiver releases from the switch (it will move outward slightly), then pull it from the slot.

To remove the transceivers that have the wire bail, lower the bail until it is approximately horizontal, and then using the bail, pull the transceiver from the slot.

## Hot Swapping SFP/SFP+/SFP28/QSFP+/QSFP28 Transceivers

Supported SFP/SFP+/SFP28/QSFP+/QSFP28 transceivers that you can install in your HPE Aruba Networking switch can be hot swapped—removed and installed while the switch is receiving power. However, disconnect the network cables from the SFP/SFP+/SFP28/QSFP+/QSFP28 transceivers before hot-swapping them.

When you replace an SFP/SFP+/SFP28/QSFP+/QSFP28 transceiver with another transceiver of a different type, the switch may retain selected port-specific configuration settings that were configured for the replaced unit. Be sure to validate or reconfigure port settings as required.

## SFP/SFP+/SFP28/QSFP+/QSFP28 Connections to Devices with Fixed Speed/duplex Configurations

When connecting a device to your switch port that contains an SFP/SFP+/SFP28/QSFP+/QSFP28 transceiver, the speed and duplex settings of the switch port and the connected device must match. Otherwise, the device may not link properly—you may not get a link. For some older network devices, the default speed/duplex settings may be predefined (for example, to 1000 Mbps/Full Duplex), or otherwise set differently from the default configuration of your switch. These setting differences may also apply to some older Hewlett Packard Enterprise devices. Because of these default speed/duplex considerations, make sure that devices connected to your SFP/SFP+/SFP28/QSFP+/QSFP28 ports are properly configured. At a minimum, make sure the configurations match.

## Interface-Group Operation

The SFP28 ports in the HPE Aruba Networking 8325-48Y8C switches (JL624A, JL625A, JL857A, and JL858A) are organized into four groups of 12 ports each.



The HPE Aruba Networking 8325-32C switches (JL626A, JL627A, JL859A, and JL860A) do not support interface groups.

**Figure 25** Front of the HPE Aruba Networking 8325-48Y8C (JL624A, JL625A, JL857A, and JL858A) interface-groups

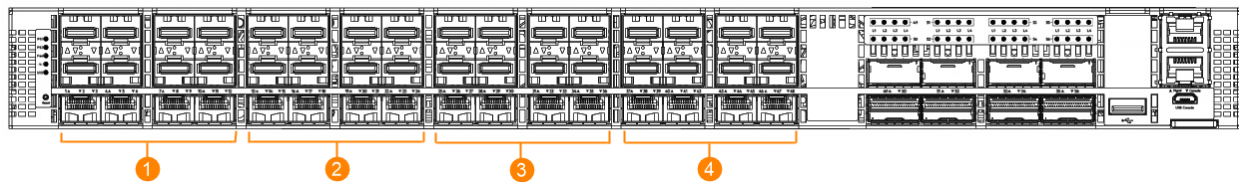

**Table 25:** HPE Aruba Networking 8325-48Y8C (JL624A, JL625A, JL857A, and JL858A) Interface-groups

Label	Description
1	Interface-group 1 (ports 1 to 12)
2	Interface-group 2 (ports 13 to 24)

Label	Description
3	Interface-group 3 (ports 25 to 36)
4	Interface-group 4 (ports 37 to 48)

The port speed configured for a given interface group determines the speed for all ports in that group. Any mismatched interfaces in the group are disabled. For example, if interface group 1 is configured for 25 G (the default setting) and 10 G transceivers are installed in ports 10 and 11, these two transceivers are in a mismatch state and are disabled with the port error logged as **group speed mismatch**. The port LED will flash amber to indicate an installation error was detected. All fault indications will flash in unison with the Global Status LED to alert the user.

In the default switch configuration, all four interface-groups are configured to 25 Gbps. To configure the speed for an interface-group to 10 Gbps, use the following command:

```
system interface-group <1|2|3|4> speed <10g|25g>
```

For example, to configure interface-group 1 for 10 G, use this command:

```
8325(config)# system interface-group 1 speed 10g
```

Once entered, the switch will present the warning and required user response:

```
Changing the group speed will disable all member interfaces that do not match the new speed.
```

```
Continue (y/n)? y
```

Only the 10 G interface-group speed setting supports 1 Gbps transceivers. The 1 Gbps optical transceivers also require the user to manually configure the port to 1000-full mode, an additional configuration to ensure IEEE-compliant operation. For example, the following command is also required for 1 G optics (do not use with 10 G optics/DACs):

```
8325(config)# int 1/1/1 speed 1000-full
```

For more information, and to view or change the speed setting for a port group, see the HPE Aruba Networking 8325 Fundamentals Guide for ArubaOS-CX 10.02 or later at

<https://asp.arubanetworks.com/downloads>.

## 1 GBase-T (J8177D) Transceiver Support Restrictions in the 48-port 8325 Switches

Beginning with software release 10.03, the HPE Aruba Networking 8325-48YBC switches also support 1 GBase-T (J8177D) transceivers in all the top row and middle row ports. The bottom row ports do not support 1 GBase-T (J8177D) transceiver operation.

**Figure 26** 1 GBase-T Transceiver Support for the 48-port 8325 Switches

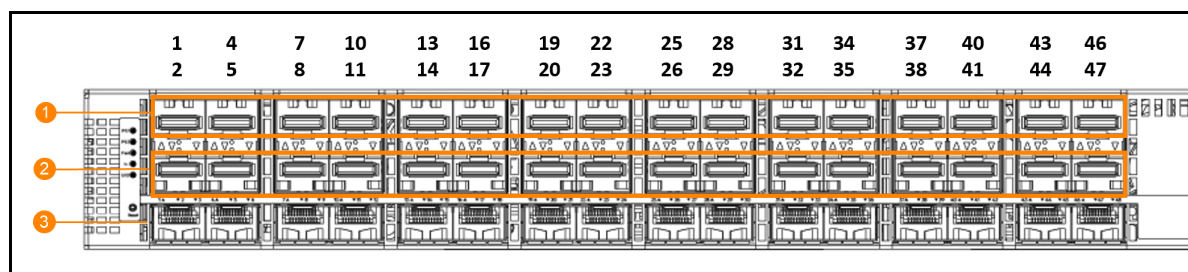

**Table 26:** 1 GBase-T Transceiver Support for the 48-port 8325 Switches

Label	Description
1	All top row ports support 1 GBase-T (J8177D) transceivers.

Label	Description
2	All middle row ports support 1 GBase-T (J8177D) transceivers.
3	Bottom row ports do not support 1 GBase-T (J8177D) transceivers.
Ports not occupied by a J8177D RJ45 transceiver continue to support optical, DAC, or AOC products.	

If the switch detects a 1 GBase-T (J8177D) transceiver in any bottom row port, the `show interface brief` command will list an `Incompatible interface` for that port.

### 10 GBase-T (JL563A) Transceiver Support Restrictions in the 48-port 8325 Switches

Beginning with software release 10.03, the HPE Aruba Networking 8325-48YBC switches also support 10 GBase-T (JL563A) transceivers in the following top row and middle row ports:

**Figure 27** 10 GBase-T Transceiver Support for the 48-port 8325 Switches

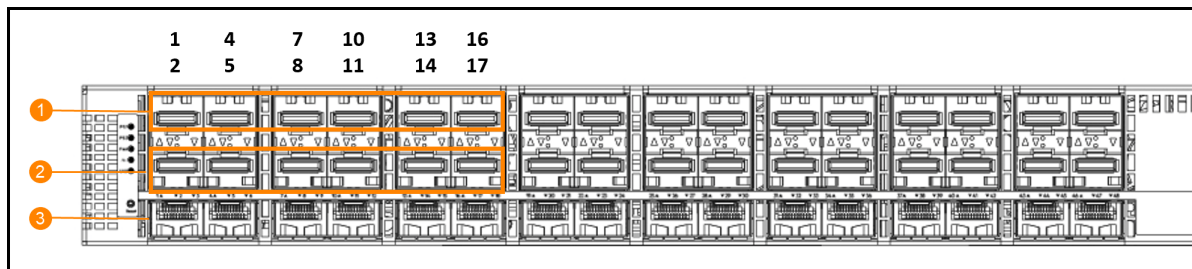

**Table 27:** 10 GBase-T Transceiver Support for the 48-port 8325 Switches

Label	Description
1	Top row ports 1, 4, 7, 10, 13, and 16 support 10 GBase-T (JL563A) transceivers.
2	Middle row ports 2, 5, 8, 11, 14, and 17 support 10 GBase-T (JL563A) transceivers.
3	Bottom row ports do not support 10 GBase-T (JL563A) transceivers.
Ports not occupied by a JL563A RJ45 transceiver continue to support optical, DAC, or AOC products.	

To enable use on ports 13-17, Interface-Group 2 must be set to 10 G operation.

If the switch detects a 10 GBase-T (JL563A) transceiver in any port that does not support it, the `show interface brief` command will list an `Incompatible interface` for that port.



The switch does not support 10 GBase-T (JL563A) transceivers in ports 3, 6, 9, 12, 15, 18, and 19 through 48. 10 GBase-T support for ports 13 and 14, and 16 and 17 was added with software release 10.03.

## Connect the Switch to a Power Source

To connect the switch to a power source, complete the following steps:

1. If a power supply is not already installed in the switch, install at least one power supply. (See [Install Power Supplies](#).) The HPE Aruba Networking 8325 switch uses any of the following power supplies:
  - Aruba 8325 650W 100-240VAC FB PSU (JL632A)
  - Aruba 8325 650W 100-240VAC BF PSU (JL633A)
  - Aruba 8325 850W 48VDC FB PSU (JL861A)
  - Aruba 8325 850W 48VDC BF PSU (JL862A)
2. Connect an AC power cord or DC power cable to the switch and to an AC or DC power source.
3. Check the LEDs. See [Chassis LEDs on the Front of the Switch](#).



---

One power supply provides power to operate the switch. Installing a second power supply can provide power to the switch in case the initial power supply fails. If the power supplies are plugged into different power sources, redundant power can be supplied in case of loss of one of the power sources.

---

## Setup for Initial Configuration

You can perform the initial configuration of the switch using one of the following methods:

- **Using Zero Touch Provisioning (ZTP):** Use ZTP to configure a switch automatically from a remote server. The switch must be in the factory default configuration. If ZTP is to be used, your network administrator or installation site coordinator must provide an RJ45 cable connected to the appropriate network. Connect the switch to the network using the RJ45 out-of-band management port and power on the switch (or power off, then power on the switch). The ZTP operation is attempted for the first 10 minutes after the switch is powered on. For more information about ZTP, see the *Fundamentals Guide* for your switch and software release.
- **Using the HPE Aruba Networking CX mobile app:** The HPE Aruba Networking CX mobile app and the HPE Aruba Networking USB Bluetooth adapter (separately orderable SKU# S1H23A) enable you to configure your switch from your mobile device. For information about using the HPE Aruba Networking CX mobile app to configure the switch, see the *Fundamentals Guide* for your switch and software release.
- **Using an out-of-band serial console:** Use a workstation configured with a suitable VT-100 terminal emulation software and connect the workstation to the switch's RJ45 Console Port. A DB9-to-RJ45 console cable can be ordered from HPE: JL448A, HPE Aruba Networking X2C2 RJ45 to DB9 Console Cable. For more information about this method, see [Initial Configuration with an Out-of-Band Serial Connection](#).
- **Using connections to the out-of-band dedicated management network:** Use a workstation configured with a suitable VT-100 terminal emulation software and SSH software. Connect the workstation and the switch to the same management network. Connect the switch to the network using the RJ45 out-of-band management port. For more information about using this method, see the *Fundamentals Guide* for your switch and software release. The switch can simultaneously support one console session through the console port and multiple network SSH sessions through the management port.

## Connect the Network Cables

Connect the network cables, described under **Cabling Infrastructure** in [Prepare the Installation Site](#) chapter, from the network devices or your patch panels to the RJ45 out-of-band management port on the switch or to any transceivers you have installed in the switch.

## Using RJ45 Out-of-band Management Port

If you plan to manage the switch from a dedicated management network, connect an RJ45 network cable from the management network to the Mgmt port. The Mgmt port supports 10, 100, and 1000 Mbps connections.

### To Connect:

Push the RJ45 plug into the RJ45 port until the tab on the plug clicks into place. When the switch and the connected device are powered, and the ports are enabled on both ends, the Link LED for the port should light up to confirm that a powered-on device (for example, an end node) is at the other end of the cable.

If the Link LED does not turn on when the network cable is connected to the port, see [Diagnosing with the LEDs](#) in the Troubleshooting chapter.

### To Disconnect:

Press the small tab on the plug and pull the plug out of the port.

**Figure 28** *Connecting an RJ45 Cable*

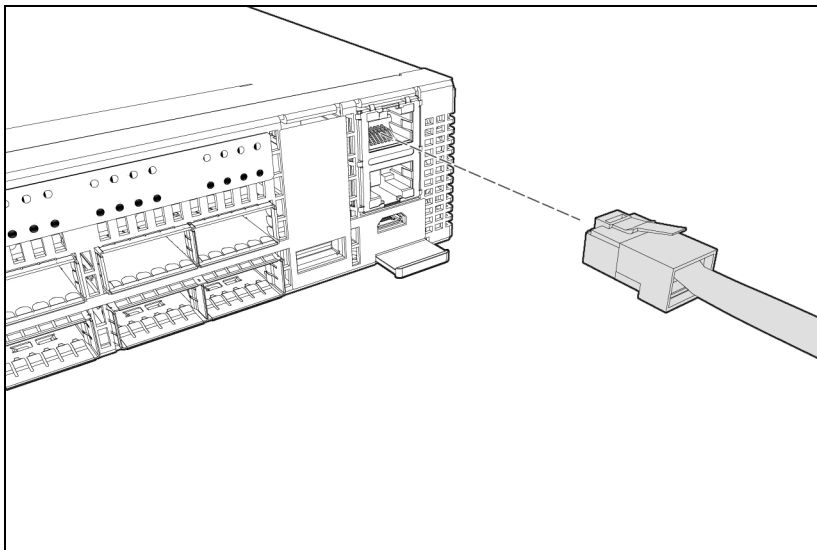

## Connecting Cables to Transceivers

If you have any transceivers installed in the switch, the type of network connections you will need to use depends on the type of transceivers installed. See [Cabling and Technology Information](#), for cabling information.

For transceiver ports, and in general for all the switch ports, a network cable from an active network device is connected to the port. If the port LED does not come on when the network cable is connected to the port, see [Diagnosing with the LEDs](#) in the Troubleshooting chapter.

**Figure 29** *Connecting a Cable to a Transceiver*

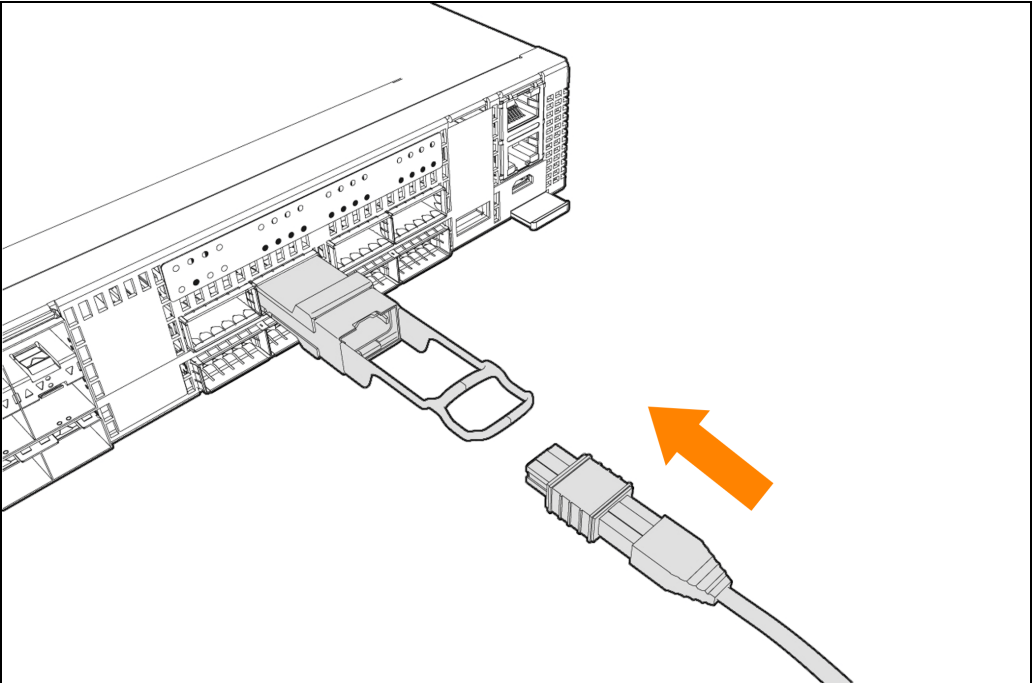

## Terminal Configuration

To configure a terminal, complete the following steps:

- Configure the PC terminal emulator as a DEC VT-100 (ANSI) terminal or use a VT-100 terminal, and configure either one to operate with the following settings:
  - Baud rate:** 115200
  - Data bits:** 8
  - Stop bit:** 1
  - Parity:** None
  - Flow control:** Off
- For the Windows Terminal program, also disable (uncheck) the **Use Function, Arrow, and Ctrl Keys for Windows** option.
- For the Hilgraeve HyperTerminal program, select the **Terminal keys** option for the **Function, Arrow, and Ctrl keys act as** parameter.



---

If you want to operate the console using a different configuration, make sure you change the settings on both the terminal and on the switch so they are compatible. Change the switch settings first, then change the terminal settings, then reboot the switch and reestablish the console session.

---

## Connect to a Console Port

To connect a console to the switch, complete the following steps:

1. Connect the PC or terminal to the switch's Console Port using a console cable (JL448A; sold separately).

**Figure 30** Connecting a Console Cable

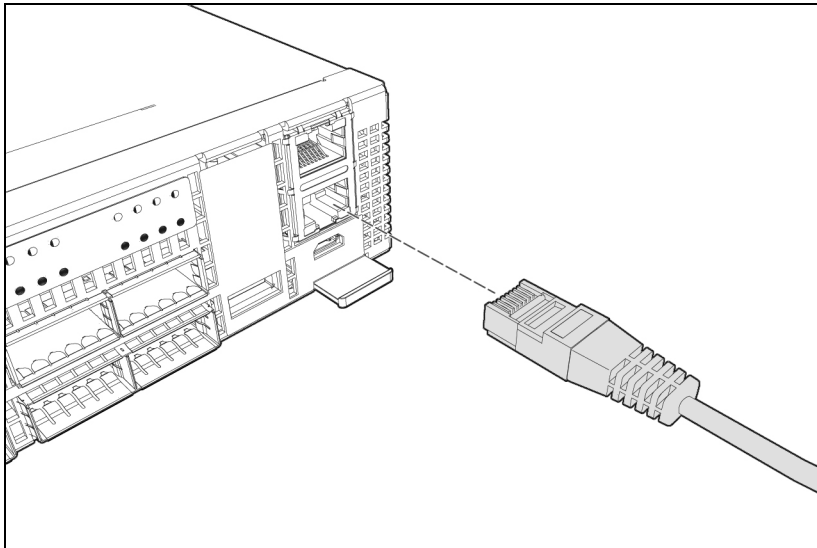

2. Turn on the terminal or PC's power and, if using a PC, start the PC terminal program.
3. Press **Enter** two or three times. When prompted to log in, specify **admin**. When prompted for the password, press **Enter**. (By default, no password is defined).

You are placed into the manager command context, which is identified by the prompt: `switch#`.  
For example:

```
login as: admin
Password:

switch#
```



If you want to continue with console management of the switch at this time, see the HPE Aruba Networking 8325 Fundamentals Guide for ArubaOS-CX for initial configuration steps. For more detailed information, refer to the switch software manuals for your switch and software version provided at <https://networkingsupport.hpe.com/downloads>.

## Console Cable Pinouts

The HPE Aruba Networking X2C2 RJ45 to DB9 Console Cable (JL448A) has an RJ45 plug on one end and a DB9 female connector on the other end.

**Figure 31** RJ45 to DB9 Pinouts

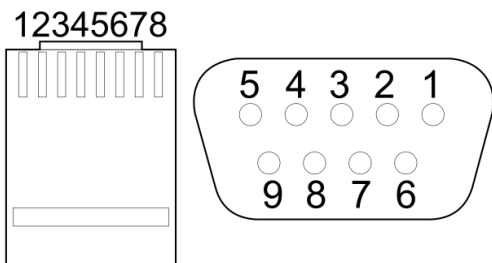

The following table describes the mapping of the RJ45 to DB9 pins.

**Table 28:** *Mapping of RJ45 to DB9*

RJ45 Signals (Signal Reference from Chassis)	RJ45 Pin	DB9 Pin	DB9 Signals (Signal reference from PC)
Reserved	1	8	CTS
Reserved	2	6	DSR
TXD	3	2	RXD
Reserved	4	1	DCD
GND	5	5	GND
RXD	6	3	TXD
Reserved	7	4	DTR
Reserved	8	7	RTS
No connection	-	9	RI

This chapter describes how to remove and install the following components:

- Power supply
- Fan assembly

The power supplies and fan assemblies are hot swappable. You do not need to power off the switch before installing or replacing a power supply or fan assembly.



- 
- The HPE Aruba Networking 8325 switch and its components are sensitive to static discharge. Use an antistatic wrist strap and observe all static precautions when replacing components.
  - If a power supply must be removed and then reinstalled, wait at least 5 seconds before re-installation. Otherwise, damage to the switch may occur. The power supply needs this time to bleed off any retained power.
- 

## Replacing a Power Supply



---

Never insert or remove a power supply while the power cord is connected. Verify that the power cord has been disconnected from the power supply before installation or removal.

---

If the HPE Aruba Networking 8325 switch is configured with a redundant power supply, the switch will not suffer any loss of traffic or performance if a power supply fails. To maintain system redundancy, a failed power supply should be replaced as soon as possible. The LED on PSU1 or PSU2 will be on amber, indicating a power supply has failed.

The following four power supplies are available for use with the switch:

- Aruba 8325 650W 100-240VAC FB PSU (JL632A) (Front-to-Back cooling air flow)
- Aruba 8325 650W 100-240VAC BF PSU (JL633A) (Back-to-Front cooling air flow)
- Aruba 8325 850W 48VDC FB PSU (JL861A) (Front-to-Back cooling air flow)
- Aruba 8325 850W 48VDC BF PSU (JL862A) (Back-to-Front cooling air flow)



---

Cooling air flow (Front-to-Back or Back-to-Front) must be the same for both the power supplies and the fans installed in the switch.

---

To remove the power supply, complete the following steps:

1. Remove the power cable from the failed power supply's connector.
2. Grasping the handle of the failed power supply, release the locking mechanism by squeezing the latch handle while removing the failed power supply.

**Figure 32** Replacing a Failed Power Supply

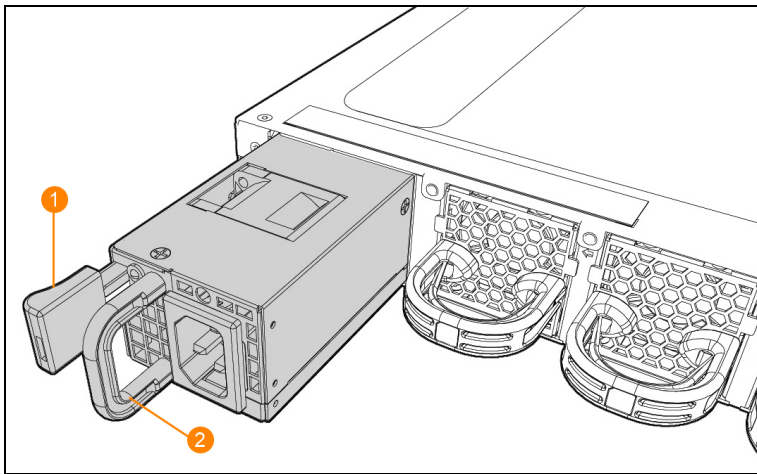

**Table 29:** Replacing a Failed Power Supply Labels and Descriptions

Label	Description
1	Release latch
2	Power supply handle

3. Insert the new power supply. Slide it all the way in until the locking mechanism clicks into place.
4. Connect the power cable to the new power supply's connector.

## Replacing a Fan Assembly

The HPE Aruba Networking 8325 switch is equipped with six field-replaceable, hot-swappable fan assemblies. The switch can tolerate the failure of a single fan assembly while maintaining a safe operating temperature. To maintain system redundancy, a failed fan assembly should be replaced as soon as possible. The Fan LED will be on amber, indicating a fan assembly has failed.

The 8325-48Y8C and 8325-32C switches use different fan assemblies. Each fan assembly type can only be installed in the correct switch model.

The following two fan assemblies are available for use with the 8325-48Y8C switches:

- Aruba 8325-48Y8C Front-to-Back Fan (JL628A)
- Aruba 8325-48Y8C Back-to-Front Fan (JL629A)

The following two fan assemblies are available for use with the 8325-32C switches:

- Aruba 8325-32C Front-to-Back Fan (JL630A)
- Aruba 8325-32C Back-to-Front Fan (JL631A)



- The HPE Aruba Networking 8325 switch is not compatible with fan assemblies from other HPE Aruba Networking hardware platforms.
- After removing a fan assembly, wait at least five seconds before inserting a replacement fan assembly in the same slot.
- Replace only one fan assembly at a time. Removing more than one fan assembly at a time compromises system cooling, risks damage to the hardware, and can cause the switch to shut down abruptly.
- If there are less than six fan assemblies installed, a two minute count down timer is triggered. If six fan assemblies are not present before the countdown expires, the switch will automatically power down and reboot. For this reason, it is not recommended to remove a failed fan assembly, until you have the replacement fan assembly prepared.

Ensure that a replacement fan has the same airflow direction as other fans installed in the switch (FB or BF).

To replace a fan tray, complete the following steps:

1. Identify the failed fan assembly by its status LED. The fan assembly LED will be on red, or flashing red.
2. Remove the new fan assembly from its packaging, being careful to not touch any of the circuitry on the board.
3. Loosen the retaining screw on the fan assembly in the 8325-32C switches. For a fan assembly in the 8325-48Y8C switches, pull the release latch on the inside of the fan assembly handle.
4. Grasping the handle of the failed fan assembly, pull it straight out to remove it from its slot.
5. Insert the new fan assembly fully into the slot so that its face plate is flush with the back face of the switch. If the switch is connected to an AC power source, the fan assembly should immediately start running.
6. For the 8325-32C fan assembly, engage the retaining screw and tighten it. Be sure to not over-tighten the screw.

**Figure 33** *Replacing a Failed Fan Assembly*

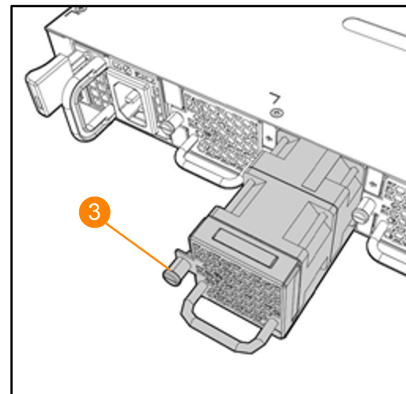
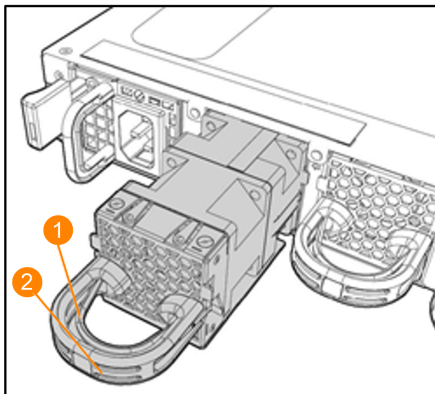

**Table 30:** *Replacing a Failed Fan Assembly Labels and Descriptions*

Label	Description
1	Fan assembly release latch
2	Fan assembly handle
3	Fan assembly retaining screw

This chapter describes how to troubleshoot your switch. This document describes troubleshooting primarily from a hardware perspective. You can perform more in-depth troubleshooting on these devices using the software tools available with the switches, including the full-featured console interface, the built-in web browser interface, and HPE Aruba Networking Central or HPE Aruba Networking AirWave.

This chapter describes the following:

- [Basic Troubleshooting Tips](#)
- [Diagnosing with the LEDs](#)
- [Hardware Diagnostic Tests](#)
- [Downloading New Switch Software](#)
- [Hewlett Packard Enterprise Customer Support Services](#)

## Basic Troubleshooting Tips

Most problems are caused by the following situations. Check for these items first when starting your troubleshooting:

- **Faulty or loose cables:** Look for loose or obviously faulty connections. If the cables appear to be OK, make sure the connections are snug. If that does not correct the problem, try a different cable.
- **Non-standard cables:** Non-standard and miswired cables may cause network collisions and other network problems, and can seriously impair network performance. Use a new correctly-wired cable or compare your cable to the [Cabling and Technology Information](#) for pinouts and correct cable wiring.
- **Transceiver type not supported by port:** A 1 GBase-T or 10 GBase-T transceiver is installed in a port that does not support the transceiver type. Only the first two rows of ports in HPE Aruba Networking 48YBC switches support 1 GBase-T (J8177D) transceivers. Only the first six ports in rows 1 and 2 in HPE Aruba Networking 48YBC switches support 10 GBase-T transceivers. For more information, see:
  - [1 GBase-T \(J8177D\) Transceiver Support Restrictions in the 48-port 8325 Switches](#)
  - [10 GBase-T \(JL563A\) Transceiver Support Restrictions in the 48-port 8325 Switches](#)
- **Improper network topologies:** It is important to make sure you have a valid network topology. Common topology faults include excessive cable lengths. If you have network problems after recent changes to the network, change back to the previous topology. If you no longer experience the problems, the new topology is most likely at fault.

In addition, you should make sure that your network topology contains **no data path loops**. Between any two end nodes, there should be only one active cabling path at any time. Data path loops can cause broadcast storms that will severely impact your network performance.

For your switch, if you want to build redundant paths between important nodes in your network to provide some fault tolerance, you should enable **Spanning Tree Protocol** support on the switch. This

ensures that only one of the redundant paths is active at any time, thus avoiding data path loops. Spanning Tree can be enabled through the switch console or the web browser interface. For more information on Spanning Tree, see the Layer 2 Bridging Guide for your switch at <https://networkingsupport.hpe.com/downloads>.



By default, ports do not run selftest at boot. To enable port selftest on boot, save the **no fastboot** configuration to the switch. See the AOS-CX software documentation for further details.

## Diagnosing with the LEDs

### LED Patterns for General Switch Troubleshooting

1. Check in the following table for the LED pattern you see on your switch.
2. Refer to the corresponding diagnostic tip on the next few pages.

**Table 31:** LED Error Indicators

LED Pattern Indicating Problems				
PSU1/PSU2 LEDs	Global Status	Fan	Port LED	Diagnostic Tip
Off with power cords plugged in	-	-	-	1
On amber <sup>1</sup>	Flashing amber	-	-	2
On green	Flashing amber	On amber	-	3
On green	Flashing amber	-	Flashing amber	4
On green	On green	-	Off with cable connected	5
On green	On green	-	On, but the port is not communicating	6

<sup>1</sup> Either the PS1 or PS2 LED is on amber, but not both.

### Diagnostic Tips

The following table describes the diagnostic tips.

**Table 32:** Diagnostic Tips

Tip	Problem	Solution
1	Both switch power supplies are not plugged into an active power source.	<ul style="list-style-type: none"> <li>■ Verify the power source works by connecting it to another device. Or try connecting the power supplies to different power sources, or try different power cords.</li> <li>■ If the problem is still not resolved, both power supplies or the switch may be faulty.</li> </ul>

Tip	Problem	Solution
2	One of the power supplies is not plugged into an active power source, or the power supply may have failed.	<ul style="list-style-type: none"> <li>■ Verify the AC power cord or DC power cable is connected to an active power source and to the power supply. Make sure these connections are snug.</li> <li>■ Use the <code>show environment power-supply</code> command to check the status of the power supply.</li> <li>■ Try power cycling the switch by disconnecting the power and connecting it to the other working power supply.</li> <li>■ If the PS1/PS2 LED is still not on, verify that the power source works by connecting another device to it. Or try connecting the switch to a different power source or try a different AC power cord or DC power cable.</li> <li>■ If the power source and power cable are OK and this condition persists, the switch power supply may have failed. Call your Hewlett Packard Enterprise-authorized network reseller, or use the electronic support services from Hewlett Packard Enterprise to get assistance.</li> </ul>
3	One of the switch fan assemblies may have failed.	Try disconnecting power from the switch and wait a few moments. Then reconnect the power to the switch and check the LEDs again. If the error indication reoccurs, one of the fan assemblies has failed. The switch may continue to operate under this condition if the ambient temperature does not exceed normal room temperature, but for best operation, the fan assembly should be replaced. Call your Hewlett Packard Enterprise-authorized network reseller, or use the electronic support services from Hewlett Packard Enterprise to get assistance.
4	The network port for which the LED is flashing has experienced a self test, initialization failure.	<ul style="list-style-type: none"> <li>■ Try power cycling the switch. If the fault indication reoccurs: <ul style="list-style-type: none"> <li>■ There may be a port configuration mismatch where a 10 G transceiver is installed in a port configured for 25 G, or the reverse.</li> <li>■ A 10 GBase-T transceiver may be installed in an incompatible port. See the <a href="#">Optional Network Connectivity, Speeds, and Technologies</a> table for list of supported ports.</li> <li>■ The transceiver may have failed.</li> <li>■ The switch port may have failed.</li> </ul> </li> <li>■ Check the switch Event Log and show interface command output for indication of the fault condition.</li> <li>■ If the port has an SFP/SFP+/SFP28 transceiver or QSFP+/QSFP28 transceiver installed, verify that the transceiver is supported by the switch. Unsupported or unrecognized transceivers will be identified with this fault condition. For a list of supported transceivers, see the ArubaOS-Switch and ArubaOS-CX Transceiver Guide at <a href="https://networkingsupport.hpe.com/downloads">https://networkingsupport.hpe.com/downloads</a>.</li> <li>■ The port group speed settings may not match the transceiver. Use the switch console to see how the port group speed is configured. For more information on port group speed settings, see <a href="#">Interface-Group Operation</a>.</li> </ul>

Tip	Problem	Solution
		<ul style="list-style-type: none"> <li>■ The transceivers are also tested when they are hot-swapped—installed or changed while the switch is powered on.</li> <li>■ To verify the port has failed, remove and reinstall the transceiver without powering off the switch. If the port fault indication reoccurs, you will have to replace the transceiver. Check the event log to see why the transceiver failed. If the fault indication persists after the transceiver has been removed, the switch port is faulty and the switch will need to be replaced.</li> <li>■ To get assistance, call your Hewlett Packard Enterprise-authorized network reseller, or use the electronic support services from Hewlett Packard Enterprise.</li> </ul>
5	The network connection is not working properly.	<p>Try the following procedures:</p> <ul style="list-style-type: none"> <li>■ For the indicated port, verify that both ends of the cabling, at the switch and the connected device, are connected properly.</li> <li>■ Verify that the connected device and switch are both powered on and operating correctly.</li> <li>■ Verify you have used the correct cable type for the connection: <ol style="list-style-type: none"> <li>1. For fiber-optic connections, verify the transmit port on the switch is connected to the receive port on the connected device, and the switch receive port is connected to the transmit port on the connected device.</li> <li>2. The cable verification process must include all patch cables from any end devices, including the switch, to any patch panels in the cabling path.</li> </ol> </li> <li>■ Verify the port has not been disabled through a switch configuration change. You can use the console interface, or, if you have configured an IP address on the switch, use the Web browser interface to determine the state of the port and re-enable the port if necessary.</li> <li>■ Verify the switch port configuration matches the configuration of the attached device. For example, if the switch port is configured as <b>Full-duplex</b>, the port on the attached device also <b>MUST</b> be configured as <b>Full-duplex</b>. If the configurations don't match, the results could be a very unreliable connection, or no link at all.</li> <li>■ If the other procedures don't resolve the problem, try using a different port or a different cable.</li> </ul>
6	The port may be improperly configured, or the port may be in a <b>blocking</b> state by the normal operation of the Spanning Tree, LACP, or IGMP features.	<ul style="list-style-type: none"> <li>■ Use the switch console to see if the port is part of a dynamic trunk (through the LACP feature) or to see if Spanning Tree is enabled on the switch, and to see if the port may have been put into a <b>blocking</b> state by those features. The <code>show lacp interfaces</code> command displays the port status for the LACP feature; the <code>show spanning-tree</code> command displays the port</li> </ul>

Tip	Problem	Solution
		<p>status for Spanning Tree.</p> <ul style="list-style-type: none"> <li>Also check the Port Status screen using the <code>show interfaces</code> command to see if the port has been configured as <b>disabled</b>.</li> <li>Other switch features that may affect the port operation include VLANs and IGMP. Use the switch console to see how the port is configured for these features.</li> <li>Ensure also, that the device at the other end of the connection is indicating a good link to the switch. If it is not, the problem may be with the cabling between the devices or the connectors on the cable.</li> </ul>

## Hardware Diagnostic Tests

This section describes the basic tests for checking hardware.

### Testing the Switch by Resetting It

If you believe the switch is not operating correctly, you can reset the switch to test its circuitry and operating code. To reset a switch, complete either of the following steps:

- Unplug and plug in the power cord (power cycling). Wait a minimum of five seconds after unplugging, before plugging the power cord back in.
- Press the **Reset** button on the front of the switch.
- Reboot the switch through the management console's `boot system` command.



---

Power cycling the switch and pressing the **Reset** button causes the switch to reset. The reset process also causes any network traffic counters and the System Up Time timer to be reset to zero.

---

### Checking the Switch LEDs

See [Diagnosing with the LEDs](#) for information on interpreting the LED patterns.

### Checking Console Messages

Useful diagnostic messages may be displayed on the console screen when the switch is reset. Connect a PC running a VT-100 terminal emulator program to the switch's Console Port and configure it to run at 115200 baud, and with the other terminal communication settings shown in [Connect the Network Cables](#). Then, when you reset the switch, note the messages that are displayed. Additionally, you can check the switch event log, which can be accessed from the console using the `show events` command.

### Testing Switch-to-Device Network Communications

You can perform the following communication tests to verify the network is operating correctly between the switch and any connected device that can respond correctly to the communication test.

- **Link Test:** A physical layer test that sends IEEE 802.2 test packets to any device identified by its MAC address.
- **Ping Test:** A network layer test used on IP networks that sends test packets to any device identified by its IP address.

These tests can be performed through the switch console interface from a terminal connected to the switch or through a Telnet connection, or from the switch's web browser interface.

## Testing End-to-End Networking Communications

Both the switch and the cabling can be tested by running an end-to-end communications test—a test that sends known data from one network device to another through the switch. For example, if you have two PCs on the network that have LAN adapters between which you can run a link-level test or Ping test through the switch, you can use this test to verify that the entire communication path between the two PCs is functioning correctly. See your LAN adapter documentation for more information on running a link test or Ping test.

## Battery



---

This switch uses a lithium battery to maintain internal clock time across a reboot or power cycle. Do not attempt to replace the battery. Return the switch to HPE Aruba Networking for battery replacement.

---

**IMPORTANT:** The only indicator of battery failure is the failure of the switch internal clock to keep the correct time across a reboot or power cycle. **No other switch operation is affected, and the switch does not require battery power to function properly.**

- To reset the switch internal clock, see the **Clock Commands** chapter or, for NTP (network time protocol) server operation, the **NTP Commands** chapter in the latest Command Line Interface Guide for your switch software. To locate this guide, visit the HPE Networking Support Portal at <https://networkingsupport.hpe.com/downloads> and filter for Product Family, Product Series, and Document File Contents.
- If the battery fails and you want to replace it, contact your authorized HPE Aruba Networking representative for assistance. Batteries are not customer-serviceable. Battery failures should only be referred to service personnel authorized by HPE Aruba Networking.

For important safety, environmental, and regulatory information, see Safety and Compliance Information for Server, Storage, Power, Networking, and Rack Products, available at <http://www.hpe.com/support/Safety-Compliance-EnterpriseProducts>.

**ATTENTION:** Il y a danger d'explosion s'il y a un remplacement incorrect de la batterie.

Remplacer uniquement avec une batterie du même type ou d'un type équivalent recommandé par le constructeur.

Mettre au rebut les batteries usagées conformément aux instructions du fabricant.

**ATTENTION:** The battery supplied with this product may contain perchlorate material. Special handling may apply in California and certain other states. Visit <http://www.dtsc.ca.gov/hazardouswaste/perchlorate> for more information.



---

A risk of explosion exists if a battery is replaced with an incorrect type. Dispose of used batteries according to the battery disposal regulations for your country or region.

---

## Downloading New Switch Software

Software Updates can be downloaded to the switch through several methods. See [Accessing Updates](#).

## Hewlett Packard Enterprise Customer Support Services

If you are still having trouble with your product, see [Support and Other Resources](#).

## Switch Specifications

This section lists specifications for the 8325 switch series.

### Physical

The following table describes the physical specifications of the switch.

**Table 33:** *Physical Specifications*

Switch Model	Dimensions (W x D x H)	Weight
Aruba 8325-48Y8C FB 6 F 2 PS Bdl (JL624A) Aruba 8325-48Y8C BF 6 F 2 PS Bdl (JL625A) Aruba 8325-48Y8C FB 6 F 2 DC Bdl (JL857A) Aruba 8325-48Y8C BF 6 F 2 DC Bdl (JL858A)	17.26 x 21.1 x 1.69 in (43.8 x 53.6 x 4.3 cm)	22 lb (10 kg)
Aruba 8325-32C FB 6 F 2 PS Bdl (JL626A) Aruba 8325-32C BF 6 F 2 PS Bdl (JL627A) Aruba 8325-32C FB 6 F 2 DC Bdl (JL859A) Aruba 8325-32C BF 6 F 2 DC Bdl (JL860A)	17.26 x 20.28 x 1.69 in (43.8 x 51.5 x 4.3 cm)	21 lb (9.5 kg)

### Electrical

The following table describes the electrical specifications of the switch.

**Table 34:** *Electrical Specifications*

Switch Model	Voltage	Maximum Current	Frequency Range
Aruba 8325 650W 100-240VAC FB PSU (JL632A)* Aruba 8325 650W 100-240VAC BF PSU (JL633A)*	100-240 volts AC	6 A - 3 A	50-60Hz
Aruba 8325 850W 48VDC FB PSU (JL861A) Aruba 8325 850W 48VDC BF PSU (JL862A)	-36 -- -72 volts DC	28 - 14 A	-
* Power supplies automatically adjust to any voltage between 100 volts and 240 volts, and either 50 or 60 Hz.			

## Power Consumption

The following table describes the power consumption specifications of the switch.

**Table 35:** *Power Consumption Specifications*

Switch Model	Power Consumption
Aruba 8325-48Y8C FB 6 F 2 PS Bdl (JL624A) Aruba 8325-48Y8C BF 6 F 2 PS Bdl (JL625A) Aruba 8325-48Y8C FB 6 F 2 DC Bdl (JL857A) Aruba 8325-48Y8C BF 6 F 2 DC Bdl (JL858A)	Max: 550 W, 1877 BTU/hr Idle: 209 W, 713 BTU/hr
Aruba 8325-32C FB 6 F 2 PS Bdl (JL626A) Aruba 8325-32C BF 6 F 2 PS Bdl (JL627A) Aruba 8325-32C FB 6 F 2 DC Bdl (JL859A) Aruba 8325-32C BF 6 F 2 DC Bdl (JL860A)	Max: 550 W, 1877 BTU/hr Idle: 143 W, 488 BTU/hr
Aruba 8325 650W 100-240VAC FB PSU (JL632A) Aruba 8325 650W 100-240VAC BF PSU (JL633A)	Max: 650 W, 2218 BTU/hr
Aruba 8325 850W 48VDC FB PSU (JL861A) Aruba 8325 850W 48VDC BF PSU (JL862A)	Max: 850 W, 2900 BTU/hr



- 100% traffic measured with IMIX traffic rates, transceivers and fans.
- Idle power measured with no transceivers or cables installed at room temperature.

## MTBF

The following table describes the MTBF specifications of the switch.

**Table 36:** *MTBF Specifications*

Switch Model	MTBF
Aruba 8325-48Y8C FB 6 F 2 PS Bdl (JL624A) Aruba 8325-48Y8C BF 6 F 2 PS Bdl (JL625A) Aruba 8325-48Y8C FB 6 F 2 DC Bdl (JL857A) Aruba 8325-48Y8C BF 6 F 2 DC Bdl (JL858A)	183165.4 hours
Aruba 8325-32C FB 6 F 2 PS Bdl (JL626A) Aruba 8325-32C BF 6 F 2 PS Bdl (JL627A) Aruba 8325-32C FB 6 F 2 DC Bdl (JL859A) Aruba 8325-32C BF 6 F 2 DC Bdl (JL860A)	155725.2 hours

## Environmental

The following table describes the environmental specifications of the switch.

**Table 37: Environmental Specifications**

HPE Aruba Networking 8325 Switch Series (JL624A, JL625A, JL626A, JL627A, JL857A, JL858A, JL859A, and JL860A)		
	Operating	Non-Operating
Temperature	0°C to 40°C (32°F to 104°F) up to 3.0 km (10,000 ft)	-40°C to 70°C (-40°F to 158°F) up to 4.6 km (15,000 ft)
Relative humidity (non-condensing)	5% to 95% at 40°C (104°F) non-condensing	5% to 95% at 65°C (149°F)
Max altitude	3.0 km (10,000 ft)*	4.6 km (15,000 ft)

\* The operating maximum altitude should not exceed that of any accessory being connected to any HPE Aruba Networking 8325 switch.

## Acoustics

The following table describes the acoustic specifications of the switch.

**Table 38: Acoustic Specifications**

Switch Model	Acoustics
Aruba 8325-48Y8C FB 6 F 2 PS Bdl (JL624A) Aruba 8325-48Y8C BF 6 F 2 PS Bdl (JL625A)	Sound Pressure (LpAm) (Bystander) 90.8 dB Sound Pressure (LpAm) (Bystander) 88.3 dB
Aruba 8325-32C FB 6 F 2 PS Bdl (JL626A) Aruba 8325-32C BF 6 F 2 PS Bdl (JL627A)	Sound Pressure (LpAm) (Bystander) 87.4 dB Sound Pressure (LpAm) (Bystander) 85.1 dB



Acoustics are measured in 23± 2°C hemi-anechoic chamber with a loading of 100% traffic on all ports. The ports are populated with 400G AOC and transceivers: 2x R9B44A, 12x R9B42A, 18x R9B41A. Acoustic sound levels are measured in accordance with ECMA-74:2019. The values presented is the mean bystander A-weighted Sound Pressure Level (LpAm).

## RoHS

EN 50581:2012

## Standards

The following table describes the technology standards and safety compliance details.

**Table 39: Technology Standards and Safety Compliance**

Technology	Compatible with these IEEE Standards	Laser Safety Information	
		EN/IEC Standard Compliance	Lasers
1000 BASE-T	IEEE 802.3ab 1000 BASE-T	-	-

Technology	Compatible with these IEEE Standards	Laser Safety Information	
		EN/IEC Standard Compliance	Lasers
1000 BASE-SX	IEEE 802.3z 1000 BASE-SX	EN/IEC 60825	Class 1 Laser Product Laser Klasse 1
1000 BASE-LX	IEEE 802.3z 1000 BASE-LX	EN/IEC 60825	Class 1 Laser Product Laser Klasse 1
1000 BASE-LH	(Not an IEEE standard)	EN/IEC 60825	Class 1 Laser Product Laser Klasse 1
10 GBASE-T	IEEE 802.3an 10 GBASE-T	-	-
10 GBASE-SR	IEEE 802.3ae 10 GBASE-SR	EN/IEC 60825	Class 1 Laser Product Laser Klasse 1
10 GBASE-LR	IEEE 802.3ae 10 GBASE-LR	EN/IEC 60825	Class 1 Laser Product Laser Klasse 1
10 GBASE-ER	IEEE 802.3ae 10 GBASE-ER	EN/IEC 60825	Class 1 Laser Product Laser Klasse 1
25 GBASE-SR	IEEE 802.3by 25 GBASE-SR	EN/IEC 60825	Class 1 Laser Product Laser Klasse 1
25 GBASE-eSR	(Not an IEEE standard)	EN/IEC 60825	Class 1 Laser Product Laser Klasse 1
25 GBASE-LR	IEEE 802.3cc 25 GBASE-LR	EN/IEC 60825	Class 1 Laser Product Laser Klasse 1
40 GBASE-SR4	IEEE 802.3ba 40 GBASE-SR4	EN/IEC 60825	Class 1 Laser Product Laser Klasse 1
40 GBASE-eSR4	(Not an IEEE standard)	EN/IEC 60825	Class 1 Laser Product Laser Klasse 1
40 GBASE-LR4	IEEE 802.3ba 40 GBASE-LR4	EN/IEC 60825	Class 1 Laser Product Laser Klasse 1
40 GBASE-ER4	IEEE 802.3bm 40 GBASE-ER4	EN/IEC 60825	Class 1 Laser Product Laser Klasse 1
40 GBASE-Bidi	(Not an IEEE standard)	EN/IEC 60825	Class 1 Laser Product Laser Klasse 1
100 GBASE-SR4	IEEE 802.3bm 100 GBASE-SR4	EN/IEC 60825	Class 1 Laser Product Laser Klasse 1
100 GBASE-LR4	IEEE 802.3ba 100 GBASE-LR4	EN/IEC 60825	Class 1 Laser Product Laser Klasse 1

**Table 40:** *Network Equipment-Building System (NEBS)*

- SR-3580, Level 3, NEBS Criteria Levels
- GR-1089-CORE, EMC & Electrical Safety
- GR-63-CORE, Physical Protections
- ETSI EN 300 386, Class A, EMC
- ETSI EN 300 019-2-1, Class 1.2, Storage
- ETSI EN 300 019-2-2, Class 2.3, Transportation
- ETSI EN 300 019-2-3, Class 3.1 & 3.1E, Stationary Use at Weather Protected Locations
- ETSI 300 132, Power Supply Interface to Telecom Equipment, -48VDC
- ETSI ETS 300 753, Acoustic Noise

This chapter describes the switch connector information and network cable information for cables that should be used with the Hewlett Packard Enterprise switches.



Incorrectly wired cabling is a common cause of problems for LAN communications. Hewlett Packard Enterprise recommends that you work with a qualified LAN cable installer for assistance with your cabling requirements.

### Cabling Specifications

The following table describes the cabling specifications.

**Table 41: Cabling Specifications**

<b>Twisted-pair copper</b>	1000 Mbps Operation	Category 5, 100-ohm 4-pair UTP or STP cable, complying with IEEE 802.3ab 1000 BASE-T specifications—Category 5e or better is recommended. See <a href="#">1000 BASE-T Cable Requirements</a> .
	10 Gbps Operation	<ul style="list-style-type: none"> <li>■ Category 6 or 6A, 100-ohm 4-pair UTP cable, or Category 6A or 7, 100-ohm 4-pair STP cable, complying with IEEE 802.3an 10 GBASE-T specifications.</li> <li>■ See <a href="#">10 GBASE-T Cable Requirements</a> below, and see <a href="#">Technology Distance Specifications</a> for distances supported with each cable type.</li> <li>■ CAT6A F/FTP, S/FTP, SF/FTP highly recommended in noisy environments. Refer to HPE Aruba Networking Support_Advisory_JL563A_10 GBaseT_APSC-RS20180403-01 for more information.</li> </ul>
<b>Twinaxial copper</b>	Direct attach cables	One-piece devices consisting of a cable with SFP+ connectors permanently attached to each end, complying with SFF 8431 SFP+ specifications.
<b>Multimode fiber</b>	-	62.5/125 μm or 50/125 μm (core/cladding) diameter, low metal content, graded index fiber-optic cables, complying with the ITU-T G.651 and ISO/IEC 793-2 Type A1b or A1a standards respectively.
<b>Single mode fiber</b>	-	9/125 μm (core/cladding) diameter, low metal content fiber-optic cables, complying with the ITU-T G.652 and ISO/IEC 793-2 Type B1 standards.

---

## 1000 BASE-T Cable Requirements



- The Category 5 networking cables that work for 100 BASE-TX connections should also work for 1000 BASE-T, as long as all four-pairs are connected. But, for the most robust connections, you should use cabling that complies with the Category 5e specifications, as described in Addendum 5 to the TIA-568-A standard (ANSI/TIA/EIA-568-A-5).
- Because of the increased speed provided by 1000 BASE-T (Gigabit-T), network cable quality is more important than for either 10 BASE-T or 100 BASE-TX. Cabling plants being used to carry 1000 BASE-T networking must comply with the IEEE 802.3ab standards. In particular, the cabling must pass tests for Attenuation, Near-End Crosstalk (NEXT), and Far-End Crosstalk (FEXT). Additionally, unlike the cables for 100 BASE-TX, the 1000 BASE-T cables must pass tests for Equal-Level Far-End Crosstalk (ELFEXT) and Return Loss.
- When testing your cabling, be sure to include the patch cables that connect the switch and other end devices to the patch panels on your site. The patch cables are frequently overlooked when testing cable and they must also comply with the cabling standards.

---

## 10 GBASE-T Cable Requirements



- The Category 6 networking cables that work for 1000 BASE-T connections may work for 10 GBASE-T, as long as the distance is less than 30m and the cable installation has been tested for compliance to IEEE requirements. But, for the most robust connections, you should use cabling that complies with the Category 6A or Category 7 specifications, as described in the TIA-568-C (ANSI/TIA-568-C.2) and ISO/IEC 11801 standards. 10 GBASE-T is a sophisticated technology that relies on high quality cable installations. It is sensitive to Alien Near End Crosstalk (ANEXT) which can be generated on the cable due to cables placed in close proximity to the data cables. It is recommended that cable dressing be done carefully and in compliance with recommendations in the TIA TSB-155A.
- Like 1000 BASE-T, 10 GBASE-T requires testing of all the crosstalk and return loss parameters described above, and also ANEXT.
- In addition to ANEXT, 10 GBASE-T is more sensitive to external electrical noise in the environment. It is recommended that radio transmitters and other sources of high frequency continuous wave radio frequency be kept away from LAN cables.
- When testing your cabling, be sure to include the patch cables that connect the switch and other end devices to the patch panels on your site. The patch cables are frequently overlooked when testing cable and they must also comply with the cabling standards.
- For 10 GBASE-T, Category 6 patch cables are sensitive to movement once the link has been established, and could cause the link to drop if moved. Therefore, Hewlett Packard Enterprise recommends using Category 6A patch cables, or using cable management options to tie down (dress) the Category 6 patch cables so they cannot move.
- For Conducted and Radiated Immunity in accordance with EN55024, the HPE Aruba Networking switch is limited to Performance Criteria A with shielded cables (CAT6A).

## Technology Distance Specifications

The following table describes the technology distance specifications.

**Table 42:** *Technology Distance Specifications*

Technology	Supported Cable Type	Multimode Fiber Modal Bandwidth	Supported Distances
1000 BASE-T	Twisted-pair copper	N/A	Up to 100 meters
1000 BASE-SX	Multimode fiber	160 MHz*km 200 MHz*km 400 MHz*km 500 MHz*km	2 - 220 meters 2 - 275 meters 2 - 500 meters 2 - 550 meters
1000 BASE-LX	Single mode fiber	N/A	2 - 10,000 meters
1000 BASE-LH	Single mode fiber	N/A	2 - 70,000 meters <sup>2</sup>
10 GBASE-T1	Twisted-pair copper	N/A	Cat 6A unshielded - up to 100 meters <sup>2</sup> Cat 6A shielded - up to 100 meters Cat 7 shielded - up to 100 meters
10 GBASE-CR (Direct Attach)	Twinaxial copper	N/A	Various lengths offered
10 GBASE-SR	Multimode fiber	160 MHz*km 200 MHz*km 400 MHz*km 500 MHz*km 2000 MHz*km	2 - 26 meters 2 - 33 meters 2 - 66 meters 2 - 82 meters 2 - 300 meters
10 GBASE-LR	Single mode fiber	N/A	2 - 10,000 meters
10 GBASE-ER	Single mode fiber	N/A	2 - 40,000 meters <sup>3</sup>
25 GBASE-CR	Twinaxial copper	N/A	Various lengths offered
25 GBASE-SR	Multimode fiber	1500 MHz*km 3500 MHz*km	2 - 70 meters 2 - 100 meters
25 GBASE-eSR	Multimode fiber	1500 MHz*km 3500 MHz*km	2 - 200 meters 2 - 400 meters
25 GBASE-LR	Single mode fiber	N/A	2 - 10,000 meters
40 GBASE-CR4	Twinaxial copper	N/A	Various lengths offered

Technology	Supported Cable Type	Multimode Fiber Modal Bandwidth	Supported Distances
40 GBASE-SR4	Multimode fiber	1500 MHz*km 3500 MHz*km	2 - 100 meters 2 - 150 meters
40 GBASE-eSR4	Multimode fiber	1500 MHz*km 3500 MHz*km	2 - 330 meters 2 - 550 meters
40 GBASE-LR4	Single mode fiber	N/A	2 - 10,000 meters
40 GBASE-ER4	Single mode fiber	N/A	2 - 40,000 meters <sup>2</sup>
40 GBASE-BiDi	Multimode fiber	1500 MHz*km 3500 MHz*km	2 - 100 meters 2 - 150 meters
100 GBASE-CR4	Twinaxial copper	N/A	Various lengths offered
100 GBASE-SR4	Multimode fiber	1500 MHz*km 3500 MHz*km	2 - 100 meters 2 - 150 meters
100 GBASE-LR4	Single mode fiber	N/A	2 - 10,000 meters

1 Refer to [Optional Network Connectivity, Speeds, and Technologies](#) table, footnote 3, for ports that support 10 GBase-T transceivers.

2 The JL563A 10 GBase-T transceiver is limited to a 30m cable length.

3 For distances less than 20km, a 10dB attenuator must be used. For distances between 20km and 40km, a 5dB attenuator must be used. Attenuators can be purchased from most cable vendors.

### Accessing HPE Aruba Networking Support

HPE Aruba Networking Support Services	<a href="https://www.arubanetworks.com/support-services/">https://www.arubanetworks.com/support-services/</a>
HPE Networking Support Portal	<a href="https://networkingsupport.hpe.com">https://networkingsupport.hpe.com</a>
North America telephone	1-800-943-4526 (US & Canada Toll-Free Number) +1-408-754-1200 (Primary - Toll Number) +1-650-385-6582 (Backup - Toll Number - Use only when all other numbers are not working)
International telephone	<a href="https://www.arubanetworks.com/support-services/contact-support/">https://www.arubanetworks.com/support-services/contact-support/</a>

Be sure to collect the following information before contacting Support:

- Technical support registration number (if applicable)
- Product name, model or version, and serial number
- Operating system name and version
- Firmware version
- Error messages
- Product-specific reports and logs
- Add-on products or components
- Third-party products or components

#### Other Useful Sites

Listed below are other websites that can be used to find information:

Airheads social forums and Knowledge Base	<a href="https://community.arubanetworks.com/">https://community.arubanetworks.com/</a>
Software licensing	<a href="https://lms.arubanetworks.com/">https://lms.arubanetworks.com/</a>
End-of-Life information	<a href="https://www.arubanetworks.com/support-services/end-of-life/">https://www.arubanetworks.com/support-services/end-of-life/</a>
HPE Aruba Networking software and documentation	<a href="https://networkingsupport.hpe.com/downloads">https://networkingsupport.hpe.com/downloads</a>

### Accessing Updates

You can access updates from the HPE Networking Support Portal or the HPE My Networking Website.

## HPE Networking Support Portal

<https://networkingsupport.hpe.com/downloads>

If you are unable to find your product in the HPE Networking Support Portal, you may need to search My Networking, where older networking products can be found.

## My Networking

<https://www.hpe.com/networking/support>

To view and update your entitlements, and to link your contracts and warranties with your profile, go to the Hewlett Packard Enterprise Support Center **More Information on Access to Support Materials** page using the link below:

<https://support.hpe.com/portal/site/hpsc/aae/home/>



---

Access to some updates might require product entitlement when accessed through the Hewlett Packard Enterprise Support Center. You must have an HP Passport set up with relevant entitlements.

---

Some software products provide a mechanism for accessing software updates through the product interface. Review your product documentation to identify the recommended software update method.

To subscribe to eNewsletters and alerts, use the following link:

<https://networkingsupport.hpe.com/notifications/subscriptions> (requires an active HPE Networking Support Portal account to manage subscriptions). Security notices are viewable without an HPE Networking Support Portal account.

## Warranty Information

To view warranty information for your product, go to <https://www.arubanetworks.com/support-services/product-warranties/>.

## Regulatory Information

To view the regulatory information for your product, view the Safety and Compliance Information for Server, Storage, Power, Networking, and Rack Products, available at <https://www.hpe.com/support/Safety-Compliance-EnterpriseProducts>.

### Additional Regulatory Information

HPE Aruba Networking is committed to providing our customers with information about the chemical substances in our products as needed to comply with legal requirements, environmental data (company programs, product recycling, energy efficiency), and safety information and compliance data (RoHS and WEEE). For more information, see <https://www.arubanetworks.com/company/about-us/environmental-citizenship/>.

## Documentation Feedback

HPE Aruba Networking is committed to providing documentation that meets your needs. To help us improve the documentation, send any errors, suggestions, or comments to Documentation Feedback ([hpe-aruba-techpub@hpe.com](mailto:hpe-aruba-techpub@hpe.com)). When submitting your feedback, include the document title, part number, edition, and publication date located on the front cover of the document. For online help content, include the product name, product version, help edition, and publication date located on the legal notices page.