

Product Specification

8 Gigabit RoHS Compliant Long-Wavelength SFP+ Transceiver

FTLF1428P2BNV

PRODUCT FEATURES

- Up to 8.5 Gb/s bi-directional data links
- Hot-pluggable SFP+ footprint
- Built-in digital diagnostic functions
- 1310nm DFB laser transmitter
- Duplex LC connector
- RoHS compliant and Lead Free
- Up to 10 km on 9/125µm SMF
- Metal enclosure, for lower EMI
- Single 3.3V power supply
- Extended operating temperature range: -5°C to 85°C



APPLICATIONS

- Tri Rate 2.125 / 4.25 / 8.5 Gb/s Fibre Channel through Rate Select

Finisar's FTLF1428P2BNV SFP+ transceivers are designed for use in Fibre Channel links up to 8.5 Gb/s data rate and up to 10 km link length. They are compliant with FC-PI-4 Rev. 8.00¹ and SFF-8472 Rev 10.2³, and compatible with SFF-8432² and applicable portions of SFF-8431 Rev. 3.0⁴. The optical transceiver is compliant per the RoHS Directive 2011/65/EU⁵. See Finisar Application Note AN-2038 for more details⁶.

PRODUCT SELECTION

FTLF1428P2BNV

I. Pin Descriptions

Pin	Symbol	Name/Description	Ref.
1	V _{EET}	Transmitter Ground (Common with Receiver Ground)	1
2	T _{FAULT}	Transmitter Fault.	2
3	T _{DIS}	Transmitter Disable. Laser output disabled on high or open.	3
4	SDA	2-wire Serial Interface Data Line (MOD-DEF2)	4
5	SCA	2-wire Serial Interface Clock (MOD-DEF1)	4
6	MOD_ABS	Module Absent, connected to V _{EET} or V _{EER}	4
7	RS0	Rx Rate Select: Open or Low = 2.125 or 4.25 Gb/s Fibre Channel (Low Bandwidth) High = 8.5 Gb/s Fibre Channel (High Bandwidth)	5
8	LOS	Loss of Signal indication. Logic 0 indicates normal operation.	6
9	RS1	Tx Rate Select: Open or Low = 2.125 or 4.25 Gb/s Fibre Channel (Low Bandwidth) High = 8.5 Gb/s Fibre Channel (High Bandwidth)	5
10	V _{EER}	Receiver Ground (Common with Transmitter Ground)	1
11	V _{EER}	Receiver Ground (Common with Transmitter Ground)	1
12	RD-	Receiver Inverted DATA out. AC Coupled	
13	RD+	Receiver Non-inverted DATA out. AC Coupled	
14	V _{EER}	Receiver Ground (Common with Transmitter Ground)	1
15	V _{CCR}	Receiver Power Supply	
16	V _{CCT}	Transmitter Power Supply	
17	V _{EET}	Transmitter Ground (Common with Receiver Ground)	1
18	TD+	Transmitter Non-Inverted DATA in. AC Coupled.	
19	TD-	Transmitter Inverted DATA in. AC Coupled.	
20	V _{EET}	Transmitter Ground (Common with Receiver Ground)	1

Notes:

- Circuit ground is internally isolated from chassis ground.
- T_{FAULT} is an open collector/drain output, which should be pulled up with a 4.7k – 10k Ohms resistor on the host board if intended for use. Pull up voltage should be between 2.0V to V_{cc} + 0.3V. A high output indicates a transmitter fault caused by either the TX bias current or the TX output power exceeding the preset alarm thresholds. A low output indicates normal operation. In the low state, the output is pulled to <0.8V.
- Laser output disabled on T_{DIS} >2.0V or open, enabled on T_{DIS} <0.8V.
- Should be pulled up with 4.7k – 10kohms on host board to a voltage between 2.0V and 3.6V. MOD_ABS pulls line low to indicate module is plugged in.
- Rate select can also be set through the 2-wire bus in accordance with SFF-8472 v. 10.2. Rx Rate Select is set at Bit 3, Byte 110, Address A2h. Tx Rate Select is set at Bit 3, Byte 118, Address A2h. Note: writing a “1” selects maximum bandwidth operation. Rate select is the logic OR of the input state of Rate Select Pin and 2-wire bus.
- LOS is open collector output. Should be pulled up with 4.7k – 10kohms on host board to a voltage between 2.0V and 3.6V. Logic 0 indicates normal operation; logic 1 indicates loss of signal.

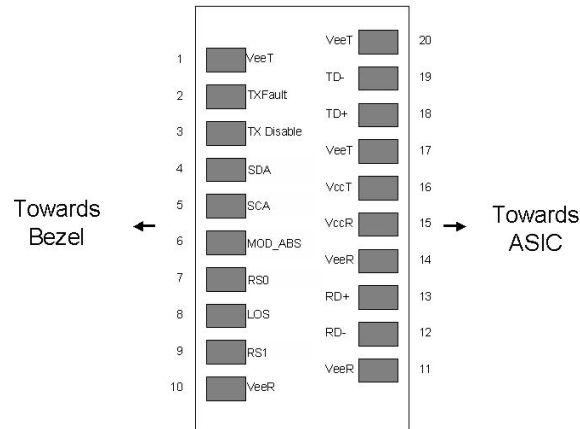

Pinout of Connector Block on Host Board

II. Absolute Maximum Ratings

Parameter	Symbol	Min	Typ	Max	Unit	Ref.
Maximum Supply Voltage	V _{CC}	-0.5		4.5	V	
Storage Temperature	T _S	-40		85	°C	
Case Operating Temperature	T _{OP}	-5		85	°C	
Relative Humidity	RH	0		85	%	1

III. Electrical Characteristics (T_{OP} = -5 to 85 °C, V_{CC} = 3.00 to 3.60 Volts)

Parameter	Symbol	Min	Typ	Max	Unit	Ref.
Supply Voltage	V _{CC}	3.00		3.60	V	2
Supply Current	I _{CC}		200	300	mA	2
Transmitter						
Input differential impedance	R _{in}		100		Ω	3
Single ended data input swing	V _{in,pp}	90		800	mV	
Transmit Disable Voltage	V _D	2		V _{CC}	V	
Transmit Enable Voltage	V _{EN}	V _{EE}		V _{EE} + 0.8	V	4
Receiver						
Single ended data output swing	V _{out,pp}	185		425	mV	5
Data output rise/fall time, 2.125, 4.25 Gb/s	t _r , t _f			120	ps	6
Data output rise/fall time, 8.5 Gb/s	t _r , t _f			60	ps	6
LOS Fault	V _{LOS fault}	2		V _{CC HOST}	V	7
LOS Normal	V _{LOS norm}	V _{EE}		V _{EE} +0.8	V	7
Power Supply Rejection	PSR	100			mVpp	8
Deterministic Jitter Contribution < 4.25 Gb/s	RX Δ DJ			51.7	ps	9,10
Total Jitter Contribution < 4.25 Gb/s	RX Δ TJ			122.4	ps	10
Deterministic Jitter Contribution = 4.25 Gb/s	RX Δ DJ			25.9	ps	9,10
Total Jitter Contribution = 4.25 Gb/s	RX Δ TJ			61.2	ps	10

Notes:

1. Non-condensing.
2. Module power consumption never exceeds 1W.
3. AC coupled.
4. Or open circuit.
5. Into 100 ohm differential termination.
6. 20 – 80 %.
7. LOS is LVTTTL. Logic 0 indicates normal operation; logic 1 indicates no signal detected.
8. All transceiver specifications are compliant with a power supply sinusoidal modulation of 20 Hz to 1.5 MHz up to specified value applied through the power supply filtering network shown on page 23 of the Small Form-factor Pluggable (SFP) Transceiver MultiSource Agreement (MSA)⁶, September 14, 2000. The Power Supply Rejection applies for a supply voltage range of 3.1 to 3.6 V.
9. Measured with DJ-free data input signal. In actual application, output DJ will be the sum of input DJ and Δ DJ.
10. For 8.5 Gb/s operation, Deterministic Jitter and Total Jitter are not specified per FC-PI-4 Rev 8.00. Jitter values for gamma T and gamma R are controlled by TDP and stressed receiver sensitivity.

IV. Optical Characteristics (T_{OP} = -5 to 85 °C, V_{CC} = 3.00 to 3.60 Volts)

Parameter	Symbol	Min	Typ	Max	Unit	Ref.
Transmitter						
Output Opt. Power, 8.5 Gb/s	P _{O,RH}	-8.4		+0.5	dBm	2
Output Opt. Power, 2.125, 4.25 Gb/s	P _{O,RL}	-8.4		-3	dBm	3
Optical Wavelength	λ	1285		1345	nm	4
Spectral Width	σ			1	nm	4
Optical Modulation Amplitude	OMA	290			μ W	4,5
Transmitter and Dispersion Penalty, 8.5 Gb/s	TDP			3.2	dB	6
Optical Rise/Fall Time, 2.125, 4.25 Gb/s	t _r / t _f			90	ps	7
RIN				-128	dB/Hz	
Receiver						
Unstressed Receiver OMA Sensitivity, 8.5 Gb/s	R _{SENSr}			0.042	mW	8
Unstressed Receiver OMA Sensitivity, 4.25 Gb/s	R _{SENS4}			0.029	mW	8
Unstressed Receiver OMA Sensitivity, 2.125 Gb/s	R _{SENS2}			0.015	mW	8
Average Received Power	R _{X,MAX}			+0.5	dBm	
Optical Center Wavelength	λ_c	1260		1360	nm	
Return Loss		12			dB	
LOS De-Assert	LOS _D			-19	dBm	
LOS Assert	LOS _A	-30			dBm	
LOS Hysteresis		0.5			dB	

Notes:

1. Class 1 Laser Safety per FDA/CDRH and EN (IEC) 60825 regulations.
2. High Bandwidth Mode. Class 1 Laser Safety per FDA/CDRH and EN (IEC) 60825 regulations.
3. Low Bandwidth Mode. Class 1 Laser Safety per FDA/CDRH and EN (IEC) 60825 regulations.
4. Also specified to meet curves in FC-PI-4 Rev 8.00¹ Figures 22 and 23, which allow trade-off between wavelength, spectral width and OMA.
5. Equivalent extinction ratio specification for Fibre Channel. Allows smaller ER at higher average power.
6. For 8.5 Gb/s operation, Jitter values for gamma T and gamma R are controlled by TDP and stressed receiver sensitivity.
7. Unfiltered, 20-80%. Complies with IEEE 802.3 (Gig. E), FC 1x and 2x eye masks when filtered.
8. Measured with conformance signals defined in FC-PI-4 Rev. 8.00 specifications. Value in OMA. Measured with PRBS 2⁷-1 at 10⁻¹² BER.

V. General Specifications

Parameter	Symbol	Min	Typ	Max	Units	Ref.
Data Rate	BR	2.125		8.5	Gb/sec	1
Bit Error Rate	BER			10^{-12}		2
Max. Supported Link Length on 9/125 μ m SMF , 2.125, 4.25, 8.5 Gb/s	L_{MAX1}		10		km	3

Notes:

1. 2x/4x/8x Fibre Channel compliant.
2. Tested with a PRBS 2^7-1 test pattern.
3. Distances are based on FC-PI-4 Rev. 8.00¹ and IEEE 802.3 standards.

VI. Environmental Specifications

These Finisar 1310nm Extended Temperature SFP+ transceivers have an operating temperature range from -5°C to $+85^{\circ}\text{C}$ case temperature.

Parameter	Symbol	Min	Typ	Max	Units	Ref.
Case Operating Temperature	T_{op}	-5		85	$^{\circ}\text{C}$	
Storage Temperature	T_{sto}	-40		85	$^{\circ}\text{C}$	

VII. Regulatory Compliance

Finisar transceivers are Class 1 Laser Products and comply with US FDA regulations. These products are certified by TÜV and CSA to meet the Class 1 eye safety requirements of EN (IEC) 60825 and the electrical safety requirements of EN (IEC) 60950. Copies of certificates are available at Finisar Corporation upon request.

VIII. Digital Diagnostic Functions

Finisar FTLF1428P2BNV SFP+ transceivers support the 2-wire serial communication protocol as defined in the SFP MSA⁶. It is very closely related to the E²PROM defined in the GBIC standard, with the same electrical specifications.

The standard SFP serial ID provides access to identification information that describes the transceiver's capabilities, standard interfaces, manufacturer, and other information.

Additionally, Finisar SFP transceivers provide a unique enhanced digital diagnostic monitoring interface, which allows real-time access to device operating parameters such as transceiver temperature, laser bias current, transmitted optical power, received optical power and transceiver supply voltage. It also defines a sophisticated system of alarm and warning flags, which alerts end-users when particular operating parameters are outside of a factory set normal range.

The SFP MSA defines a 256-byte memory map in E²PROM that is accessible over a 2-wire serial interface at the 8 bit address 1010000X (A0h). The digital diagnostic monitoring interface makes use of the 8 bit address 1010001X (A2h), so the originally defined serial ID memory map remains unchanged. The interface is identical to, and is thus fully backward compatible with both the GBIC Specification and the SFP Multi Source Agreement. The complete interface is described in Finisar Application Note AN-2030: "Digital Diagnostics Monitoring Interface for SFP Optical Transceivers".

The operating and diagnostics information is monitored and reported by a Digital Diagnostics Transceiver Controller (DDTC) inside the transceiver, which is accessed through a 2-wire serial interface. When the serial protocol is activated, the serial clock signal (SCL, Mod Def 1) is generated by the host. The positive edge clocks data into the SFP transceiver into those segments of the E²PROM that are not write-protected. The negative edge clocks data from the SFP transceiver. The serial data signal (SDA, Mod Def 2) is bi-directional for serial data transfer. The host uses SDA in conjunction with SCL to mark the start and end of serial protocol activation. The memories are organized as a series of 8-bit data words that can be addressed individually or sequentially.

For more information, please see the SFP MSA documentation^{3,6} or Finisar Application Note AN-2030.

FTLF1428P2BNV transceivers can be used in host systems that require either internally or externally calibrated digital diagnostics.

Please note that evaluation board FDB-1018 is available with Finisar ModDEMO software that allows simple to use communication over the 2-wire serial interface.

IX. Mechanical Specifications

Finisar's FTLF1428P2BNV SFP+ transceivers are compatible with the SFF-8432² specification for improved pluggable form factor.

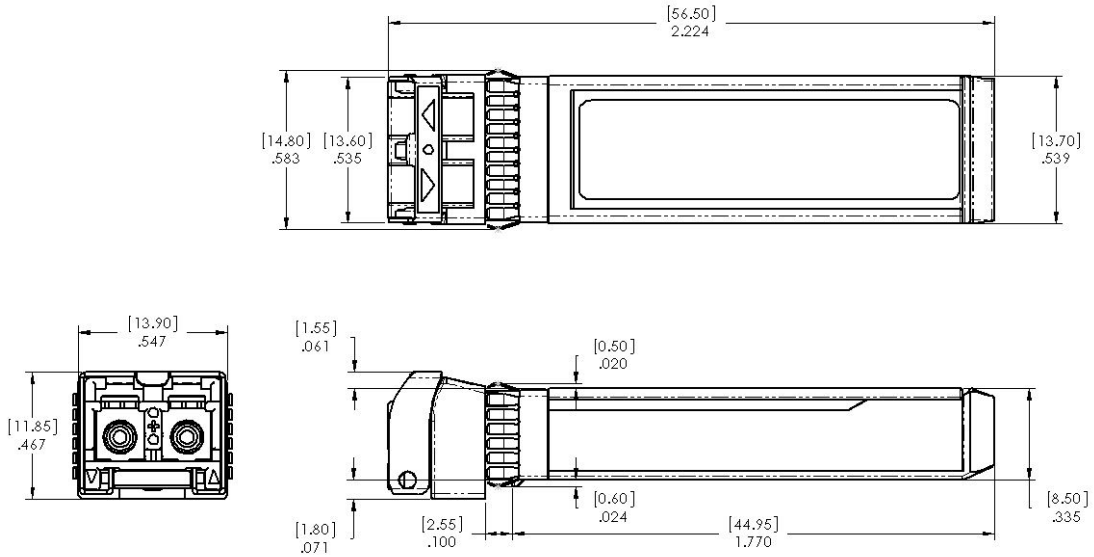

FTLF1428P2BNV

X. PCB Layout and Bezel Recommendations

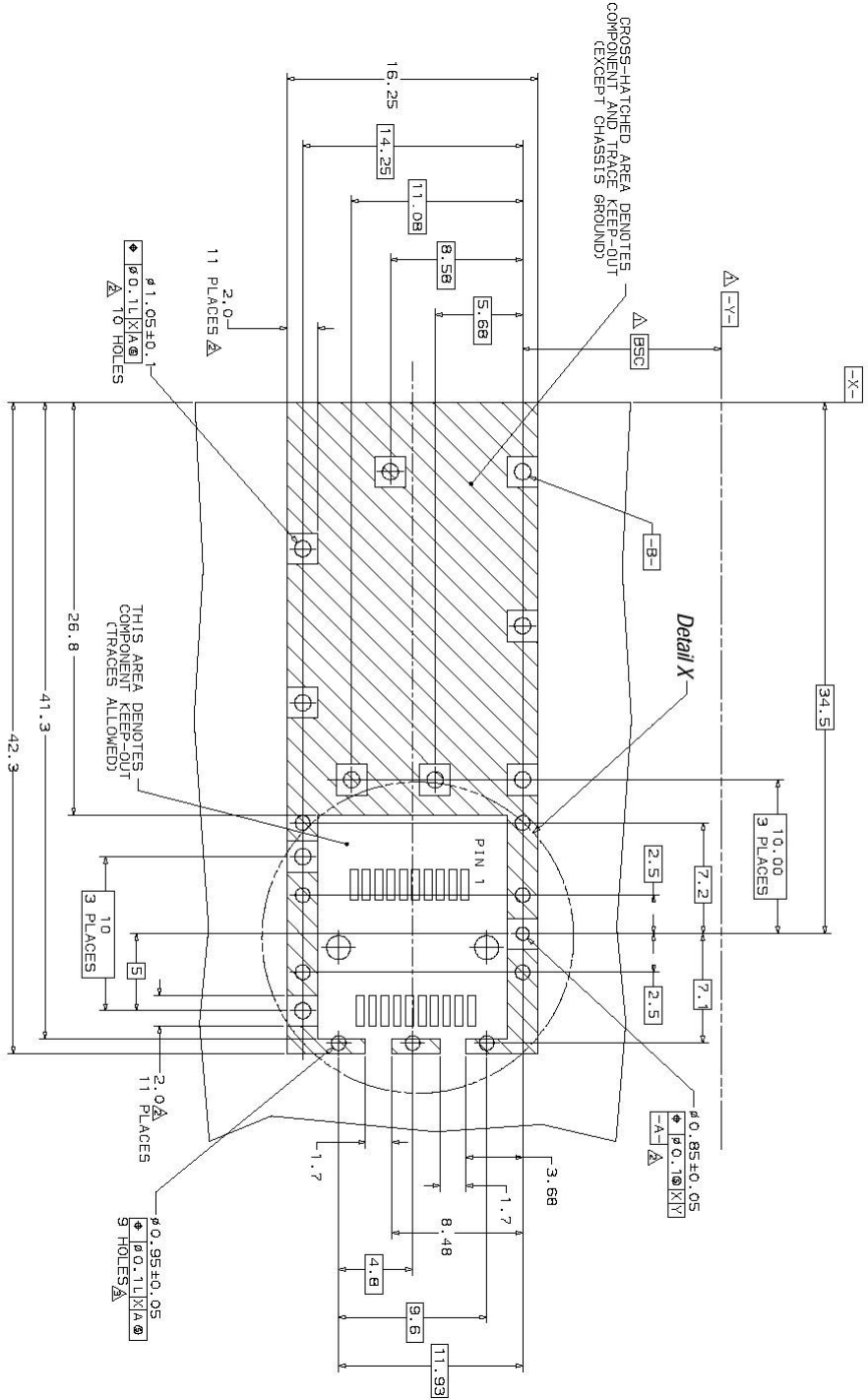

- Datum and Basic Dimension Established by Customer
- Plates and Vias are Chassis Ground, 11 Places
- Through Holes are Unplated

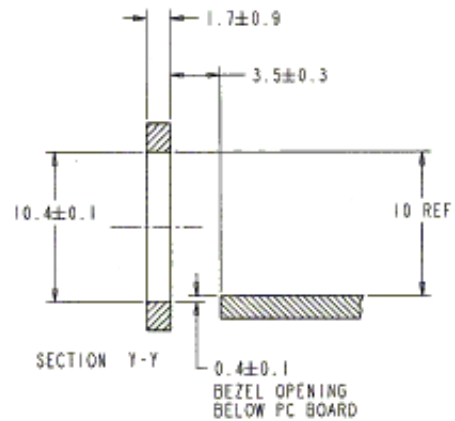
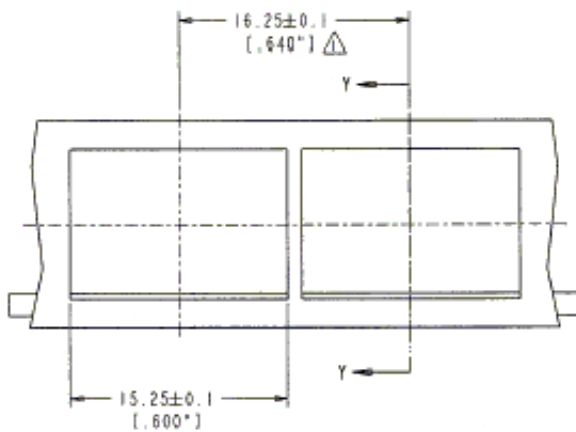
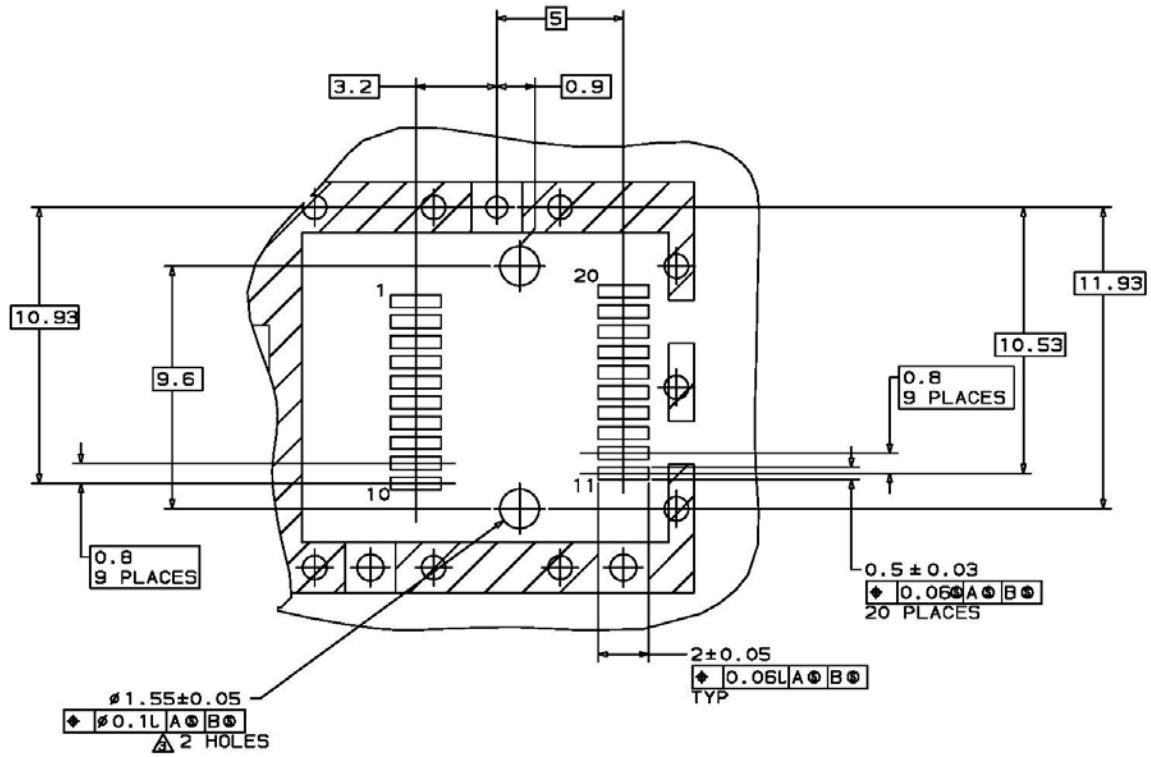

NOTES:

△ MINIMUM PITCH ILLUSTRATED, ENGLISH DIMENSIONS ARE FOR REFERENCE ONLY

2. NOT RECOMMENDED FOR PCI EXPANSION CARD APPLICATIONS

XI. References

1. “Fibre Channel Physical Interface-4 Specification (FC-PI-4 Rev. 8.00)”. American National Standard for Information Technology, May 21, 2008.
2. “Improved Pluggable Formfactor”, SFF Document Number SFF-8432, Revision 5.0, July 16, 2007.
3. “Digital Monitoring Interface for Optical Transceivers”, SFF Document Number SFF-8472, Revision 10.2, June 1, 2007.
4. “Enhanced Specification for 8.5 and 10 Gigabit Small Form Factor Pluggable Module ‘SFP+’”, SFF Document Number SFF-8431, Revision 3.0, May 8, 2008.
5. Directive 2011/65/EU of the European Council Parliament and of the Council, “on the restriction of the use of certain hazardous substances in electrical and electronic equipment”. Certain products may use one or more exemptions as allowed by the Directive.
6. “Application Note AN-2038: Finisar Implementation of RoHS Compliant Transceivers”.
7. Small Form Factor Pluggable (SFP) Transceiver Multi-source Agreement (MSA), September 14, 2000.

XII. For More Information

Finisar Corporation
1389 Moffett Park Drive
Sunnyvale, CA 94089-1134
Tel. 1-408-548-1000
Fax 1-408-541-6138
sales@finisar.com
www.finisar.com