

Cisco UCS Virtual Interface Card 1280



Cisco Unified Computing System Overview

The Cisco Unified Computing System™ (Cisco UCS™) is a next-generation data center platform that unites compute, network, storage access, and virtualization resources into a cohesive system designed to reduce total cost of ownership (TCO) and increase business agility. The system integrates a low-latency, lossless 10 Gigabit Ethernet unified network fabric with enterprise-class, x86-architecture servers. The system is an integrated, scalable, multichassis platform in which all resources participate in a unified management domain.

Product Overview

A Cisco® innovation, the Cisco UCS Virtual Interface Card (VIC) 1280 (Figure 1) is an eight-port 10 Gigabit Ethernet, Fibre Channel over Ethernet (FCoE)-capable mezzanine card designed exclusively for Cisco UCS B-Series Blade Servers. The card enables a policy-based, stateless, agile server infrastructure that can present up to 256 PCIe standards-compliant interfaces to the host that can be dynamically configured as either network interface cards (NICs) or host bus adapters (HBAs). In addition, the Cisco UCS VIC 1280 supports Cisco Virtual Machine Fabric Extender (VM-FEX) technology, which extends the Cisco UCS Fabric Interconnect ports to virtual machines, simplifying server virtualization deployment.

Figure 1. Cisco UCS VIC 1280



Features and Benefits

Stateless and Agile: The personality of the card is determined dynamically at boot time using the service profile associated with the server. The number, type (NIC or HBA), identity (MAC address and World Wide Name [WWN]), failover policy, bandwidth, and quality-of-service (QoS) policies of the PCIe interfaces are all determined using the service profile. The capability to define, create, and use interfaces on demand provides a stateless and agile server infrastructure (Figure 2).

Figure 2. Cisco UCS VIC 1280 Architecture

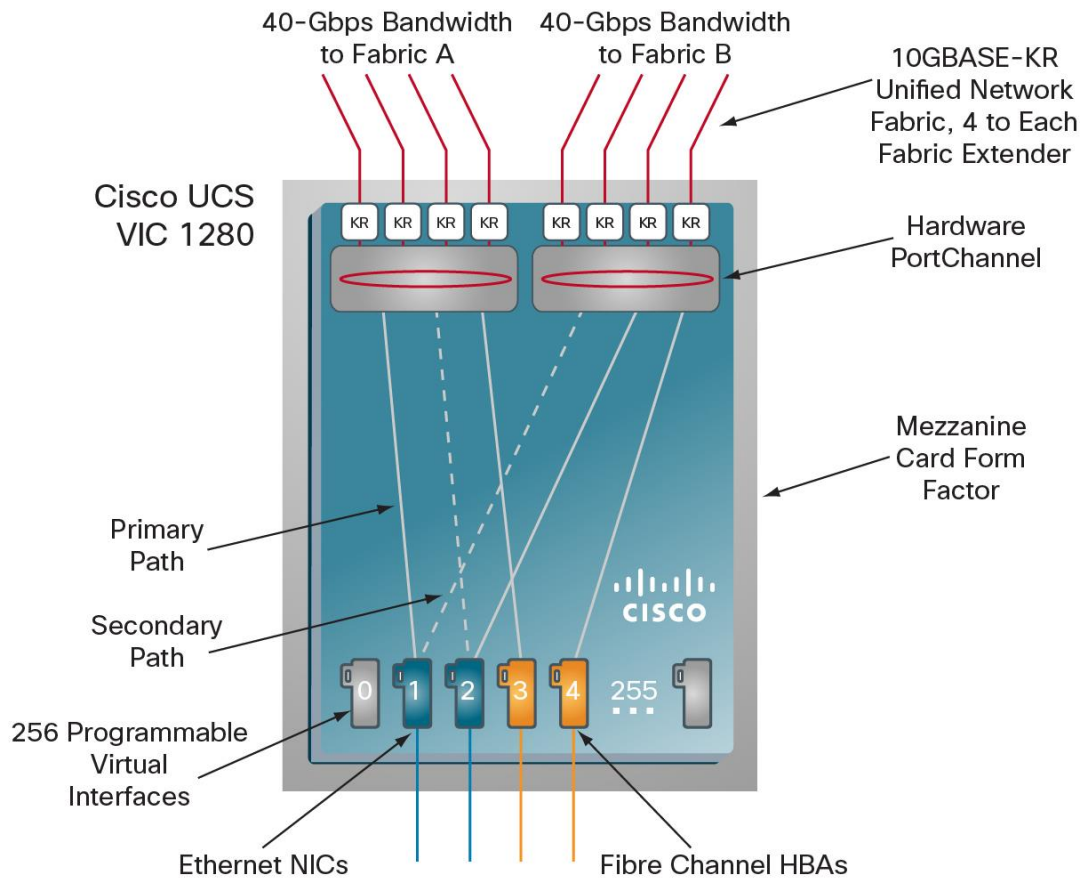

Network Interface Virtualization: Each PCIe interface created on the VIC is associated with an interface on the Cisco UCS Fabric Interconnect, providing complete network separation for each virtual cable between a PCIe device on the VIC and the interface on the Cisco UCS Fabric Interconnect.

Cisco SingleConnect Technology

Cisco® SingleConnect technology provides an exceptionally easy, intelligent, and efficient way to connect and manage computing in the data center. Cisco SingleConnect technology is an exclusive Cisco innovation that dramatically simplifies the way that data centers connect to:

- Rack and blade servers
- Physical servers and virtual machines
- LAN, SAN, and management networks

The solution addresses the challenges of today's data center, and the result is a simple, intelligent, and efficient fabric:

Easy: Cisco SingleConnect technology provides a “wire once and walk away” solution that eliminates traditional manual, time-consuming, error-prone processes and instead makes connecting servers to the Cisco Unified Computing System™ (Cisco UCS®) fast and easy.

Intelligent: the technology is intelligent because it uses a zero-touch model to allocate I/O connectivity (LAN, SAN, and management) across any type of server: physical rack and blade servers and virtual machines. The network intelligence helps Cisco UCS adapt to the needs of applications. Rather than limiting applications to specific servers, Cisco UCS makes it easy to run any workload on any server.

Efficient: the technology is highly efficient because LAN, SAN, and management connections are shared over a single network, increasing utilization while reducing the number of moving parts compared to traditional approaches with multiple networks.

Cisco SingleConnect technology is implemented with an end-to-end system I/O architecture that uses Cisco Unified Fabric and Cisco Fabric Extender Technology (FEX Technology) to connect every Cisco UCS component with a single network and a single network layer. As customers expect from Cisco, the Cisco UCS I/O architecture is based on open standards and is reliable, available, and secure.

Cisco VM-FEX Technology

Cisco VM-FEX technology extends Fabric Interconnect ports directly to virtual machines, eliminating software-based switching in the hypervisor. Cisco VM-FEX technology collapses virtual and physical networking infrastructure into a single infrastructure that is fully aware of the virtual machines' locations and networking policies (Figure 3). Cisco FEX-VM technology is implemented by Cisco VICs with a pre-standard implementation of IEEE 802.1BR Port Extender.

Figure 3. VM-FEX with Cisco UCS VIC 1280

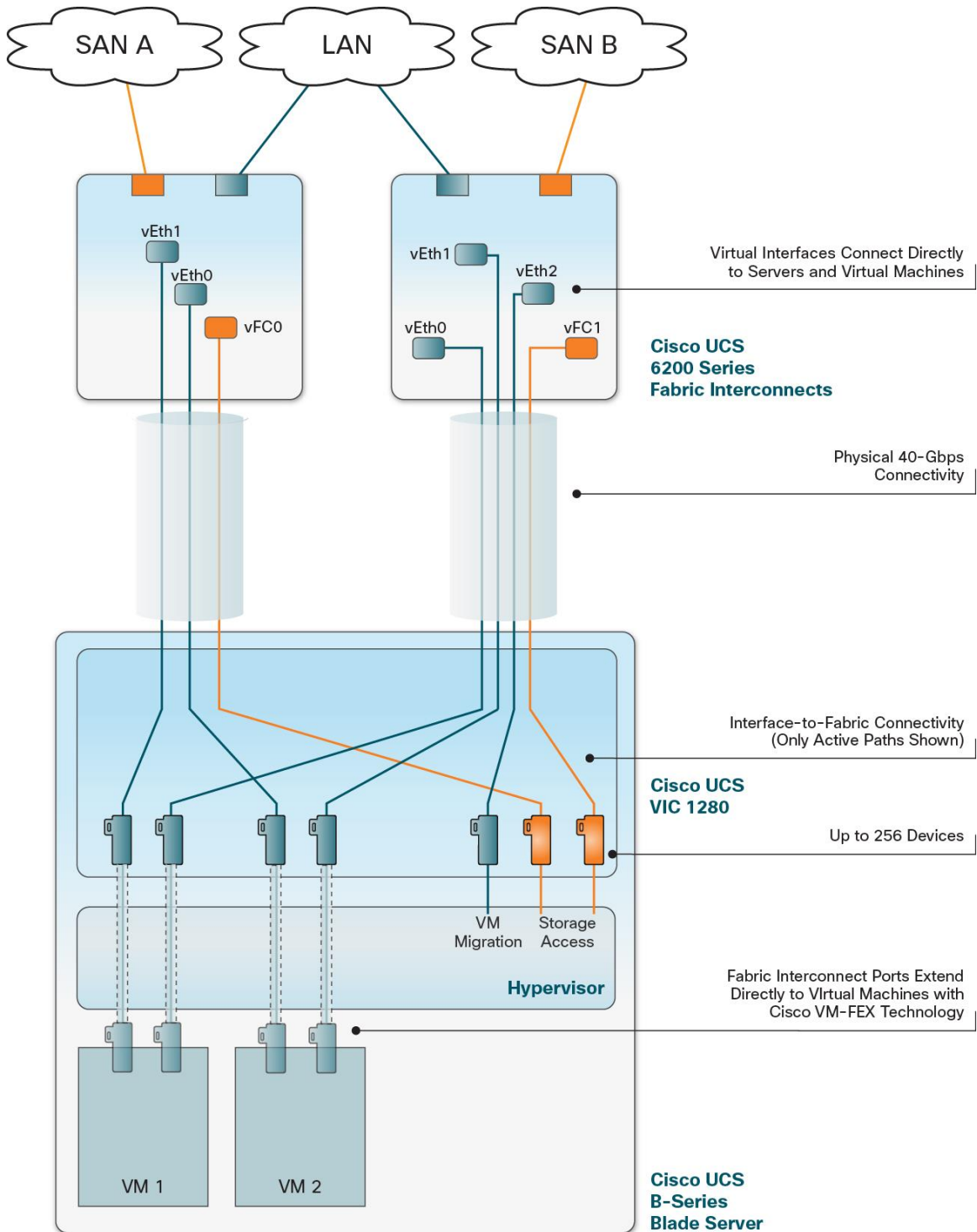

Table 1 summarizes the features and benefits of the Cisco UCS VIC 1280.

Table 1. Features and Benefits

Feature	Benefit
x16 PCIe Gen2 interfaces	Delivers greater throughput
8 x 10-Gbps unified I/O	Delivers 80 Gbps to the server Helps reduce TCO by consolidating the overall number of NICs, HBAs, cables, and switches because LAN and SAN traffic run over the same mezzanine card and fabric
Up to 256 dynamic virtual adapters and interfaces	Creates fully functional unique and independent PCIe adapters and interfaces (NICs or HBAs) without requiring single-root I/O virtualization (SR-IOV) support from OSs or hypervisors Allows these virtual interfaces and adapters to be configured and operated independently, just like physical interfaces and adapters Creates a highly flexible I/O environment needing only one card for all I/O configurations Note: Cisco UCS VIC hardware is SR-IOV capable, and you can enable SR-IOV after SR-IOV is broadly supported by the popular operating systems. Please refer to UCS Manager configuration limits for your specific OS and environment in the configuration guide
Cisco SingleConnect technology	A single unified network - the same network brings LAN, SAN, and management connectivity to each server
Cisco VM-FEX technology	Unifies virtual and physical networking into a single infrastructure Provides virtual machine visibility from the physical network and a consistent network operations model for physical and virtual servers Enables configurations and policies to follow the virtual machine during virtual machine migration Provides a prestandard implementation of the IEEE 802.1BR Port Extender standard
Centralized management	Enables the mezzanine card to be centrally managed and configured by Cisco UCS Manager
Network architecture	Provides a redundant path to the fabric interconnect using hardware-based fabric failover
More than 900,000 I/O operations per second (IOPS)	Provides high I/O performance for demanding applications
Support for lossless Ethernet	Uses Priority Flow Control (PFC) to enable FCoE as part of the Cisco unified fabric
Broad OS and hypervisor support	Supports customer requirements for Microsoft Windows, Red Hat Enterprise Linux, SUSE Linux, VMware vSphere and Citrix XenServer

Table 2 summarizes the specifications for the Cisco UCS VIC 1280.

Table 2. Product Specifications

Item	Specification
Standards	10 Gigabit Ethernet, IEEE 802.3ae, IEEE 802.3x, IEEE 802.1q VLAN, IEEE 802.1p, IEEE 802.1Qaz, IEEE 802.1Qbb, pre-standard IEEE 802.1BR jumbo frames up to 9 KB, Fibre Channel Protocol (FCP) (Small Computer System Interface [SCSI]-FCP), and T11 FCoE
Components	Cisco UCS custom ASIC
Ports	8 x 10-Gbps FCoE ports
Connectivity	Cisco UCS midplane
Performance	10-Gbps line rate per port
Management	Cisco UCS Manager Release 2.0 (2)
Number of interfaces	256 virtual interfaces (approximately 8 are reserved for internal use; other factors such as the OS and hypervisor may limit this number further)
Physical dimensions	Length = 7.25 in. (18.4 cm) Width = 3.65 in. (9.3 cm)
Typical power	12 Watts
Inlet operating temperature range	50 to 95°F (10 to 35°C)

System Requirements

The Cisco UCS VIC 1280 is designed to be used only on Cisco UCS B-Series Blade Servers.

Warranty Information

Find warranty information at Cisco.com on the [Product Warranties](#) page.

Cisco Unified Computing Services

Using a unified view of data center resources, Cisco and our industry-leading partners deliver services that accelerate your transition to a unified computing architecture. Cisco Unified Computing Services help you quickly deploy your data center resources, simplify ongoing operations, and optimize your infrastructure to better meet your business needs. For more information about these and other Cisco Data Center Services, visit <http://www.cisco.com/go/unifiedcomputingservices>.

Why Cisco?

Cisco UCS continues Cisco's long history of innovation in delivering integrated systems for improved business results based on industry standards and using the network as the platform. Recent examples include IP telephony, LAN switching, unified communications, and unified I/O. Cisco began the unified computing phase of our Data Center 3.0 strategy several years ago by assembling an experienced team from the computing and virtualization industries to augment our own networking and storage access expertise. As a result, Cisco delivered foundational technologies, including the Cisco Nexus® Family, supporting unified fabric and server virtualization. Cisco UCS completes this phase, delivering innovation in architecture, technology, partnerships, and services. Cisco is well-positioned to deliver this innovation by taking a systems approach to computing that unifies network intelligence and scalability with innovative ASICs, integrated management, and standard computing components.

Cisco Capital

Financing to Help You Achieve Your Objectives

Cisco Capital can help you acquire the technology you need to achieve your objectives and stay competitive. We can help you reduce CapEx. Accelerate your growth. Optimize your investment dollars and ROI. Cisco Capital financing gives you flexibility in acquiring hardware, software, services, and complementary third-party equipment. And there's just one predictable payment. Cisco Capital is available in more than 100 countries. [Learn more](#).

For More Information

For more information about the Cisco VIC, visit <http://www.cisco.com/en/US/products/ps10265/index.html>.



Americas Headquarters
Cisco Systems, Inc.
San Jose, CA

Asia Pacific Headquarters
Cisco Systems (USA) Pte. Ltd.
Singapore

Europe Headquarters
Cisco Systems International BV Amsterdam,
The Netherlands

Cisco has more than 200 offices worldwide. Addresses, phone numbers, and fax numbers are listed on the Cisco Website at www.cisco.com/go/offices.

 Cisco and the Cisco logo are trademarks or registered trademarks of Cisco and/or its affiliates in the U.S. and other countries. To view a list of Cisco trademarks, go to this URL: www.cisco.com/go/trademarks. Third party trademarks mentioned are the property of their respective owners. The use of the word partner does not imply a partnership relationship between Cisco and any other company. (1110R)