



This Product has been discontinued

Spec Sheet

Cisco UCS B260 M4 Blade Server (with Intel® Xeon E7 v2 CPU)

CISCO SYSTEMS
170 WEST TASMAN DR.
SAN JOSE, CA, 95134
WWW.CISCO.COM

PUBLICATION HISTORY

REV B.13 MAY 15, 2019

CONTENTS

OVERVIEW	3
DETAILED VIEWS	4
Chassis Front View	4
BASE SERVER STANDARD CAPABILITIES and FEATURES	5
CONFIGURING the SERVER	7
STEP 1 VERIFY BASE SKU	8
STEP 2 CHOOSE CPU(S)	9
STEP 3 CHOOSE MEMORY	11
STEP 4 CHOOSE HARD DISK DRIVES (HDDs) or SOLID STATE DRIVES (SSDs)	17
STEP 5 CHOOSE RAID CONFIGURATION	19
STEP 6 CHOOSE ADAPTERS	20
STEP 7 ORDER A TRUSTED PLATFORM MODULE (OPTIONAL)	27
STEP 8 ORDER OPTIONAL KVM CABLE	28
STEP 9 ORDER CISCO FLEXIBLE FLASH SECURE DIGITAL CARDS	29
STEP 10 ORDER OPTIONAL INTERNAL USB 2.0 DRIVE	30
STEP 11 CHOOSE OPERATING SYSTEM AND VALUE-ADDED SOFTWARE	31
STEP 12 CHOOSE OPERATING SYSTEM MEDIA KIT	34
STEP 13 CHOOSE SERVICE and SUPPORT LEVEL	35
SUPPLEMENTAL MATERIAL	40
Motherboard	40
DIMM and CPU Layout	43
Memory Population Recommendations	44
Memory Mixing Guidelines	45
Upgrade and Servicing-Related Parts	46
Drive and Blade Server Blanking Panels	46
Replacing a CPU (with CPU heat sink)	46
Motherboard Lithium Battery	46
CPU Removal and Installation (“pick n place”) Tool Set	47
Thermal Grease (with syringe applicator) for CPU to Heatsink Seal	47
CPU Heat Sink Cleaning Kit	48
Network Connectivity	49
VIC 1340/1240 and Port Expander	51
Connectivity Using the Cisco UCS 2208XP/2204XP Fabric Extender	52
Connectivity using the Cisco UCS 2104XP Fabric Extender	58
TECHNICAL SPECIFICATIONS	64
Dimensions and Weight	64
Power Specifications	64
Discontinued EOL Products	65

OVERVIEW

The Cisco® UCS B260 M4 High-Performance Blade Server (*Figure 1*) is a two-socket, full-width blade server supporting the Intel® Xeon® E7-8800 v2, E7-4800 v2, and E7-2800 v2 series processor family CPUs, with up to 3 terabytes¹ (TB) of double-data-rate 3 (DDR3) memory in 48 slots, up to two small form factor (SFF), hot-swappable² drive bays for hard disk drives (HDDs) or solid state drives (SSDs), two dual-port and one quad-port mezzanine slots. These slots leverage the UCS virtual interface card (VIC) technology for up to 160 Gbps aggregate I/O bandwidth. The Cisco UCS B260 M4 server is designed to power the most demanding enterprise applications.

As shown in *Figure 1*, the B260 M4 server consists of one Scalable M4 Blade Module and a Scalability Terminator.

The server is controlled with UCS Manager (UCSM) version 2.2(2).

Figure 1 Cisco UCS B260 M4 Blade Server

Front View



Notes . . .

1. A maximum of 3 TB memory is available using 64 GB DIMMs.
2. Hot-swap replacement means that you do not have to precondition or shut down the component in software before you remove it.

DETAILED VIEWS

Chassis Front View

Figure 2 shows the front of the Cisco UCS B260 M4 Blade Server.

Figure 2 Chassis Front View

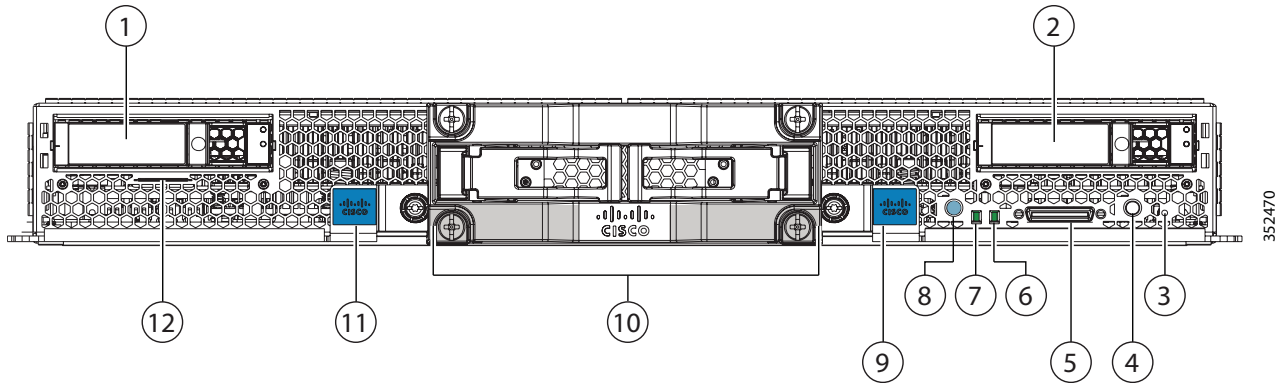

1	Drive bay 1	7	Network link status LED
2	Drive bay 2	8	Power button and LED
3	Reset button access	9	Right ejector handle
4	Beaoning button and LED	10	UCS scalability terminator
5	Local console connection ¹	11	Left ejector handle
6	Blade health LED	12	Asset tag. Each server has a blank plastic tag that pulls out of the front panel so you can add your own asset tracking label without interfering with the intended airflow.

Notes . . .

1. See [SUPPLEMENTAL MATERIAL on page 40](#) for more information about the KVM cable that plugs into the console port.

BASE SERVER STANDARD CAPABILITIES and FEATURES

Table 1 lists the capabilities and features of the base server. Details about how to configure the server for a particular feature or capability (for example, number of processors, disk drives, or amount of memory) are provided in [CONFIGURING the SERVER on page 7](#).

Table 1 Capabilities and Features

Capability/Feature	Description
Chassis	The B260 M4 Blade Server mounts in a Cisco UCS 5100 series chassis and occupies two chassis slots (each chassis slot is a half-width slot).
CPU	Two Intel® Xeon® E7-8800 v2, E7-4800 v2, or E7-2800 v2 series processor family CPUs.
Chipset	Intel® C602J chipset
Memory	48 slots for registered DIMMs. Maximum memory capacity is 3 TB ¹ . This is accomplished with 48 DIMMs, consisting of 24 DIMM kits (2 64 GB matched DIMMs per kit).
Expansion slots	<p>Two dual-port slots and one quad-port mezzanine slot are provided that can accommodate PCIe compatible adapters.</p> <p>One of the dual-port slots is dedicated for the VIC 1240 or VIC 1340 adapter which provides Ethernet and Fibre Channel over Ethernet (FCoE)</p>
	<p> NOTE: The Cisco VIC 1200 Series (1240 and 1280) is compatible in UCS domains that implement both 6100 and 6200 Series Fabric Interconnects. However, the Cisco VIC 1300 Series (1340 and 1380) is compatible only with the 6200 Series Fabric Interconnects.</p>
	<p>The other dual-port slot and the quad-port slot are used for various types of Cisco adapters and Cisco UCS Storage Accelerator adapters. The VIC 1280 and VIC 1380 can only be plugged into the quad-port slot.</p>
Storage controller	LSI SAS3008 12G SAS RAID controller, providing 12 Gbps SAS connectivity. Provides RAID 0, 1, and JBOD capability.
Internal storage devices	<ul style="list-style-type: none"> ■ Up to two optional front-accessible, hot-swappable hard disk drives (HDDs) or solid state drives (SSDs). ■ One optional USB flash drive, mounted inside the chassis ■ Dual sockets for optional Flexible Flash cards on the front left side of the server

Table 1 Capabilities and Features *(continued)*

Capability/Feature	Description
Video	<p>The Cisco Integrated Management Controller (CIMC) provides video using the Matrox G200e video/graphics controller:</p> <ul style="list-style-type: none"> ■ Integrated 2D graphics core with hardware acceleration ■ DDR2/3 memory interface supports up to 512 MB of addressable memory (8 MB is allocated by default to video memory) ■ Supports display resolutions up to 1920 x 1200 16bpp @ 60Hz ■ High-speed integrated 24-bit RAMDAC ■ Single lane PCI-Express host interface running at Gen 1 speed
Interfaces	One front-accessible console connector (see SUPPLEMENTAL MATERIAL on page 40)
Power subsystem	Integrated in the Cisco UCS 5100 series chassis
Fans	Integrated in the Cisco UCS 5100 series chassis
Integrated management processor	The built-in Cisco Integrated Management Controller (CIMC) GUI or CLI interface enables you to monitor the server inventory, health, and system event logs.

Notes . . .

1. A maximum of 3 TB memory is available using 64 GB DIMMs

CONFIGURING the SERVER

Follow these steps to configure the Cisco UCS B260 M4 Server:

- [STEP 1 VERIFY BASE SKU, page 8](#)
- [STEP 2 CHOOSE CPU\(S\), page 9](#)
- [STEP 3 CHOOSE MEMORY, page 11](#)
- [STEP 4 CHOOSE HARD DISK DRIVES \(HDDs\) or SOLID STATE DRIVES \(SSDs\), page 17](#)
- [STEP 5 CHOOSE RAID CONFIGURATION, page 19](#)
- [STEP 6 CHOOSE ADAPTERS, page 20](#)
- [STEP 7 ORDER A TRUSTED PLATFORM MODULE \(OPTIONAL\), page 27](#)
- [STEP 8 ORDER OPTIONAL KVM CABLE, page 28](#)
- [STEP 9 ORDER CISCO FLEXIBLE FLASH SECURE DIGITAL CARDS, page 29](#)
- [STEP 10 ORDER OPTIONAL INTERNAL USB 2.0 DRIVE, page 30](#)
- [STEP 12 CHOOSE OPERATING SYSTEM MEDIA KIT, page 34](#)
- [STEP 13 CHOOSE SERVICE and SUPPORT LEVEL, page 35](#)

STEP 1 VERIFY BASE SKU

Verify the product ID (PID) of the base server as shown in [Table 2](#).

Table 2 PID of the Base B260 M4 Server

Product ID (PID)	Description
UCSB-EX-M4-1C	UCS Scalable M4 Blade Module w/o CPU/DIMM/HDD for B260 M4

The B260 M4 base server:

- Does not include CPUs, memory DIMMs, SSDs, HDDs, or mezzanine cards.



NOTE: Use the steps on the following pages to configure the server with the components that you want to include.



NOTE: The B260 M4 server consists of a Scalable M4 Blade Module and a Scalability Terminator that plugs into the front of the blade module.

To upgrade from a B260 M4 server to a B460 M4 server:

- Your current B260 M4 server must be configured with two identical Intel® Xeon® E7-8800 v2 or two identical E7-4800 v2 series processor family CPUs. A B260 M4 with E7-2800 v2 CPUs cannot be upgraded.
- Order the upgrade kit (PID UCSB-EX-M4-1E-U), which consists of the following:
 - One Scalable M4 Blade Module
 - One Scalability Connector
- Configure the new Scalable M4 Blade Module with two Intel Xeon E7-8800 v2 or E7-4800 v2 series processor family CPU that are identical to the two processors in the B260 M4 server to be upgraded.



NOTE: The two CPUs in the original B260 M4 server and the two CPUs in the Scalable M4 Blade Module from the upgrade kit must be identical.

- Remove the Scalability Terminator from your original B260 M4. Install the new Scalable M4 Blade Module from the upgrade kit in the chassis slot above or below. Then install the new Scalability Connector into the front of both blade modules, connecting them together. You now have a B460 M4 server, consisting of two Scalable M4 Blade Modules ganged together by the Scalability Connector.

STEP 2 CHOOSE CPU(S)

The standard CPU features are:

- Intel Xeon E7-8800 v2, E7-4800 v2, or E7-2800 v2 series processor family CPUs
- Intel C602J chipset
- Cache size of up to 37.5 MB

Choose CPUs

The available CPUs are listed in [Table 3](#).

Table 3 Available CPUs: Intel Xeon E7-8800 v2/E7-4800 v2/E7-2800 v2 Family

Product ID (PID)	Intel Number	Clock Freq (GHz)	Power (W)	Cache Size (MB)	Cores	QPI	Highest DDR3 DIMM Clock Support (MHz)
UCS-CPU-E78893B	E7-8893 v2	3.4	155	37.5	6	8.0	1600
UCS-CPU-E78891B	E7-8891 v2	3.2	155	37.5	10	8.0	1600
UCS-CPU-E78880LB	E7-8880L v2	2.2	105	37.5	15	8.0	1600
UCS-CPU-E78857B	E7-8857 v2	3.0	130	30	12	8.0	1600
UCS-CPU-E74890B	E7-4890 v2	2.8	155	37.5	15	8.0	1600
UCS-CPU-E74880B	E7-4880 v2	2.5	130	37.5	15	8.0	1600
UCS-CPU-E74870B	E7-4870 v2	2.3	130	30	15	8.0	1600
UCS-CPU-E74860B	E7-4860 v2	2.6	130	30	12	8.0	1600
UCS-CPU-E74850B	E7-4850 v2	2.3	105	24	12	7.2	1600
UCS-CPU-E74830B	E7-4830 v2	2.2	105	20	10	7.2	1600
UCS-CPU-E74820B	E7-4820 v2	2.0	105	16	8	7.2	1600
UCS-CPU-E74809B	E7-4809 v2	1.9	105	12	6	6.4	1333
UCS-CPU-E72890B	E7-2890 v2	2.8	155	37.5	15	8.0	1600
UCS-CPU-E72880B	E7-2880 v2	2.5	130	37.5	15	8.0	1600
UCS-CPU-E72870B	E7-2870 v2	2.3	130	30	15	8.0	1600
UCS-CPU-E72850B	E7-2850 v2	2.3	105	24	12	7.2	1600

Approved Configurations

(1) Two-CPU Configuration

- Choose two identical CPUs from any one row in [Table 3](#).

Caveats

- You must choose two identical CPUs.



NOTE: The B260 M4 server consists of a Scalable M4 Blade Module and a Scalability Terminator that plugs into the front of the blade module.

You can upgrade a B260 M4 blade server later to a B460 M4 server; however, each B260 M4 server must be configured with two identical Intel Xeon E7-8800 v2 or E7-4800 v2 series processor family CPUs. A B260 M4 with E7-2800 v2 CPUs cannot be upgraded. See [To upgrade from a B260 M4 server to a B460 M4 server: on page 8](#) for details on upgrading.

STEP 3 CHOOSE MEMORY

The standard memory features are:

- DIMMs
 - Clock speed: 1600, 1333, or 1066 MHz
 - Ranks per DIMM: 4 (for 32 GB DIMMs), 2 (for 8 or 16 GB DIMMs), or 8 (for 64 GB DIMMs)
 - Operational voltage: 1.5 V or 1.35 V
 - Registered DIMM (RDIMM) or load-reduced DIMM (LRDIMM)



NOTE: You cannot mix RDIMMs with LRDIMMs

- Each CPU controls four serial memory interface 2 (SMI-2) channels. Memory buffers convert each SMI-2 channel into two DDR3 subchannels. Memory is organized as 3 DIMMs per subchannel, totaling 6 DIMMs per SMI-2 channel. See [Figure 3](#)



NOTE: Memory mirroring is supported and settable using the UCSM Service Profile “Memory RAS Configuration” setting.

Figure 3 B260 M4 Memory Organization

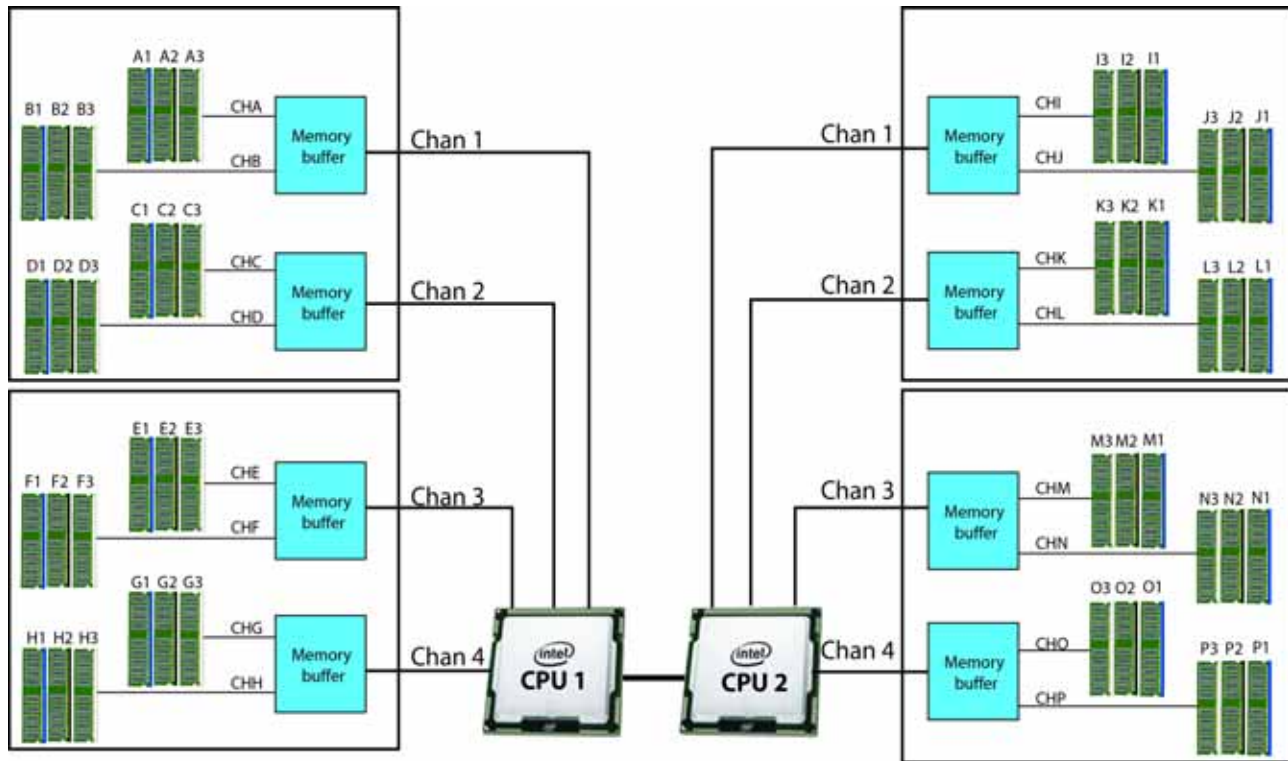

48 DIMMS
 4 memory channels per CPU,
 up to 3 DIMMs per CPU subchannel

Select DIMMs

DIMMs are available as two-DIMM kits. Each of the product IDs in [Table 4](#) specifies two DIMMs.

Table 4 Available DDR3 DIMMs

Product ID (PID)	PID Description	Voltage	Ranks/ DIMM
DIMM Pair Kit Options (2 DIMMs per kit)			
UCS-ML-2X648RY-E	2x64GB DDR3-1600-MHz LRDIMM/PC-12800/octal rank/x4	1.5 V	8
UCS-ML-2X324RY-E	2x32GB DDR3-1600-MHz LRDIMM/PC-12800/quad rank /x4	1.5/1.35 V	4
UCS-MR-2X162RY-E	2X16GB DDR3-1600-MHz RDIMM/PC-12800/dual rank/x4	1.5/1.35 V	2
UCS-MR-2X082RY-E	2X8GB DDR3-1600-MHz RDIMM/PC-12800/dual rank/x2	1.5/1.35 V	2
Memory Mirroring Option			
N01-MMIRROR	Memory mirroring option		

Approved Configurations

- 48 DIMMs capacity total, up to 24 DIMMs per CPU
- Select a minimum of 1 DIMM kit (2 DIMMs) or a maximum of 12 DIMM kits (24 DIMMs) per CPU. The DIMMs for each CPU will be placed by the factory as shown in [Table 5](#). DIMM labels shown in parentheses are DIMM pairs. Refer also to [Figure 3 on page 12](#) and [DIMM and CPU Layout on page 43](#) for more information about DIMM placement and labeling.

Table 5 DIMM Population Order

DIMMs per CPU	CPU 1 DIMMs	CPU 2 DIMMs
2	(A1, B1) - blue slots	(O1, P1) - blue slots
4	(A1, B1) (C1, D1) - blue slots	(O1, P1) (L1, K1) - blue slots
6	(A1, B1) (C1, D1) (E1, F1) - blue slots	(O1, P1) (L1, K1) (M1, N1) - blue slots
8	(A1, B1) (C1, D1) (E1, F1) (G1, H1) - blue slots	(O1, P1) (L1, K1) (M1, N1) (J1, I1) - blue slots
10	(A1, B1) (C1, D1) (E1, F1) (G1, H1) - blue slots (A2, B2) - black slots	(O1, P1) (L1, K1) (M1, N1) (J1, I1) - blue slots (O2, P2) - black slots
12	(A1, B1) (C1, D1) (E1, F1) (G1, H1) - blue slots (A2, B2) (C2, D2) - black slots	(O1, P1) (L1, K1) (M1, N1) (J1, I1) - blue slots (O2, P2) (L2, K2) - black slots

Table 5 DIMM Population Order (continued)

DIMMs per CPU	CPU 1 DIMMs	CPU 2 DIMMs
14	(A1, B1) (C1, D1) (E1, F1) (G1, H1) - blue slots (A2, B2) (C2, D2) (E2, F2)- black slots	(O1, P1) (L1, K1) (M1, N1) (J1, I1) - blue slots (O2, P2) (L2, K2) (M2, N2) - black slots
16	(A1, B1) (C1, D1) (E1, F1) (G1, H1) - blue slots (A2, B2) (C2, D2) (E2, F2) (G2, H2)- black slots	(O1, P1) (L1, K1) (M1, N1) (J1, I1) - blue slots (O2, P2) (L2, K2) (M2, N2) (J2, I2)- black slots
18	(A1, B1) (C1, D1) (E1, F1) (G1, H1) - blue slots (A2, B2) (C2, D2) (E2, F2) (G2, H2)- black slots (A3, B3) - white or ivory slots	(O1, P1) (L1, K1) (M1, N1) (J1, I1) - blue slots (O2, P2) (L2, K2) (M2, N2) (J2, I2)- black slots (O3, P3) - white or ivory slots
20	(A1, B1) (C1, D1) (E1, F1) (G1, H1) - blue slots (A2, B2) (C2, D2) (E2, F2) (G2, H2)- black slots (A3, B3) (C3, D3)- white or ivory slots	(O1, P1) (L1, K1) (M1, N1) (J1, I1) - blue slots (O2, P2) (L2, K2) (M2, N2) (J2, I2) - black slots (O3, P3) (L3, K3)- white or ivory slots
22	(A1, B1) (C1, D1) (E1, F1) (G1, H1) - blue slots (A2, B2) (C2, D2) (E2, F2) (G2, H2)- black slots (A3, B3) (C3, D3) (E3, F3) - white or ivory slots	(O1, P1) (L1, K1) (M1, N1) (J1, I1) - blue slots (O2, P2) (L2, K2) (M2, N2) (J2, I2) - black slots (O3, P3) (L3, K3) (M3, N3) - white or ivory slots
24	(A1, B1) (C1, D1) (E1, F1) (G1, H1) - blue slots (A2, B2) (C2, D2) (E2, F2) (G2, H2)- black slots (A3, B3) (C3, D3) (E3, F3) (G3, H3) - white or ivory slots	(O1, P1) (L1, K1) (M1, N1) (J1, I1) - blue slots (O2, P2) (L2, K2) (M2, N2) (J2, I2) - black slots (O3, P3) (L3, K3) (M3, N3) (J3, I3) - white or ivory slots

Caveats

- **Memory Mode.** System speed is dependent on how many DIMMs are populated per channel, the CPU DIMM speed support, and the BIOS memory mode. The BIOS default memory mode is performance mode. However, the BIOS can be changed to support lockstep mode.

 - **Memory Performance Mode.** In this mode, the main memory channel from the CPU to the memory buffer runs at double the clock rate of each of the two memory subchannels from the buffer to the DIMMs, and each DIMM subchannel is accessed sequentially. For example, if the CPU channel clock speed is 2667 MHz, each of the DIMM subchannels operates at 1333 MHz. For this reason, performance mode is referred to as 2:1. Performance mode does not provide data protection, but can yield up to 1.5 times the performance of lockstep mode and is the best choice for high throughput requirements.
 - **Memory Lockstep Mode.** In this mode, the main memory channel from the CPU to the memory buffer runs at the same clock rate of each of the two memory subchannels from the buffer to the DIMMs, and both DIMM subchannels are accessed simultaneously for a double-width access. For example, if the CPU channel clock speed is 1600 MHz, each of the DIMM subchannels operates at 1600 MHz. For this reason, lockstep mode is referred to as 1:1. Memory lockstep mode provides protection against both single-bit and multi-bit errors. Memory lockstep lets two memory channels work as a single channel, moving a data word two channels wide and providing eight bits of memory correction.

■ CPU Effect on DIMM Performance

Table 6 CPU Effect on DIMM Performance

CPU Memory Mode	Advanced CPU ¹ 8.0 GT/s QPI	Standard CPU ² 7.2 GT/s QPI	Basic CPU ³ 6.4 GT/s QPI
Lockstep Mode (1:1)	1600 MHz	1600 MHz	1333 MHz
Performance Mode (2:1)	1333 MHz	1066 MHz	1066 MHz

Notes . . .

1. CPU examples: E7-2890/2880/2870 v2, E7-4890/4880/4870/4860 v2, E7-8893/8891/8857 v2
2. CPU examples: E7-2850 v2, E7-4850/4830/4820 v2
3. CPU example: E7-4809 v2

■ DIMM Clock Speeds

DIMMs run at various clock speeds depending on the DIMM voltage and number of DIMMs per channel. See [Table 7](#) and [Table 8](#).

Table 7 DIMM Performance (at 1.5 V)

DIMM GB/Rank/Type	Performance Mode (2:1) 1.5 V DIMM			Lockstep Mode (1:1) 1.5 V DIMM		
	1 DPC	2 DPC	3 DPC	1 DPC	2 DPC	3 DPC
8 GB/2R/RDIMM	1333 MHz	1333 MHz	1066 MHz	1333 MHz	1333 MHz	1066 MHz
16 GB/2R/RDIMM	1333 MHz	1333 MHz	1066 MHz	1333 MHz	1333 MHz	1066 MHz
32 GB/4R/LRDIMM	1333 MHz	1333 MHz	1333 MHz	1600 MHz	1600 MHz	1333 MHz
64 GB/8R/LRDIMM	1066 MHz	1066 MHz	1066 MHz	1066 MHz	1066 MHz	1066 MHz

Table 8 DIMM Performance (at 1.35 V)

DIMM GB/Rank/Type	Performance Mode (2:1) 1.35 V DIMM			Lockstep Mode (1:1) 1.35 V DIMM		
	1 DPC	2 DPC	3 DPC	1 DPC	2 DPC	3 DPC
8 GB/2R/RDIMM	1333 MHz	1066 MHz	N/A	1333 MHz	1066 MHz	N/A
16 GB/2R/RDIMM	1333 MHz	1066 MHz	N/A	1333 MHz	1066 MHz	N/A
32 GB/4R/LRDIMM	1333 MHz	1333 MHz	N/A	1333 MHz	1333 MHz	N/A
64 GB/8R/LRDIMM	N/A	N/A	N/A	N/A	N/A	N/A

- The only supported DIMM configurations are shown in [Table 5 on page 13](#). Although the DIMMs are sold in matched pairs, exact pairing is not required. For best results, follow the DIMM population rules.
- The B260 M4 server needs at least one two-DIMM kit installed for each CPU.
- Memory DIMMs must be installed evenly across the installed CPUs.
- Do not mix RDIMMs and LRDIMMs.
- Your selected CPU(s) can have some effect on performance. The CPUs must be of the same type.
- For DIMM size mixing rules, see [Table 26 on page 45](#).

STEP 4 CHOOSE HARD DISK DRIVES (HDDs) or SOLID STATE DRIVES (SSDs)

The standard disk drive features are:

- Small form factor (SFF) HDDs or SSDs
- Hot-swappable
- Sled-mounted

Choose Drives

The available drives are listed in [Table 9](#).



NOTE: 4K format drives are supported and qualified as bootable with Cisco UCS Manager Release 3.1(2b) and later versions.

Table 9 Available Hot-Swappable Sled-Mounted HDDs or SSDs

Product ID (PID)	PID Description	Drive Type	Capacity
HDDs			
12 Gbps Drives			
UCS-HD600G15K12G	600 GB 12G SAS 15K RPM SFF HDD	SAS	600 GB
UCS-HD450G15K12G	450 GB 12G SAS 15K RPM SFF HDD	SAS	450 GB
UCS-HD300G15K12G	300 GB 12G SAS 15K RPM SFF HDD	SAS	300 GB
UCS-HD12TB10K12G	1.2 TB 12G SAS 10K RPM SFF HDD	SAS	1.2 TB
UCS-HD900G10K12G	900 GB 12G SAS 10K RPM SFF HDD	SAS	900 GB
UCS-HD600G10K12G	600 GB 12G SAS 10K RPM SFF HDD	SAS	600 GB
UCS-HD300G10K12G	300 GB 12G SAS 10K RPM SFF HDD	SAS	300 GB
6 Gbps Drives			
UCS-HD12T10KS2-E	1.2 TB 6G SAS 10K RPM HDD	SAS	1.2 TB
SSDs			
12 Gbps Drives			
UCS-SD16TB12S4-EP	1.6 TB 2.5 inch Enterprise Performance 12G SAS SSD (10X endurance)	SAS	1.6 TB
UCS-SD800G12S4-EP	800 GB 2.5 inch Enterprise Performance 12G SAS SSD (10X endurance)	SAS	800 GB
UCS-SD400G12S4-EP	400 GB 2.5 inch Enterprise Performance 12G SAS SSD (10X endurance)	SAS	400 GB
6 Gbps Drives			

Table 9 Available Hot-Swappable Sled-Mounted HDDs or SSDs (continued)

Product ID (PID)	PID Description	Drive Type	Capacity
UCS-SD19TBKSS-EV	1.9 TB 2.5 inch Enterprise Value 6G SATA SSD (1 FWPD)(PM863)	SATA	1.9 TB
UCS-SD960GBKS4-EV	960 GB 2.5 inch Enterprise Value 6G SATA SSD	SATA	960 GB
UCS-SD800G0KS2-EP	800 GB Enterprise Performance 6G SAS SSD (Samsung 1625)	SAS	800 GB
UCS-SD480GBKSS-EV	480 GB 2.5 in Enterprise Value 6G SATA SSD (1FWPD) (PM86)	SATA	480 GB
UCS-SD400G0KS2-EP	400 GB Enterprise Performance 6G SAS SSD (Samsung 1625)	SAS	400 GB
UCS-SD240GBKS4-EV	240 GB 2.5 inch Enterprise Value 6G SATA SSD	SATA	240 GB

Approved Configurations

(1) Zero to Two Drives

- Select from 0 to 2 drives from [Table 9](#).

Caveats

- HDDs and SSDs cannot be mixed in the same server. SAS SSDs and SATA SSDs can be mixed in the same server. See [STEP 5 CHOOSE RAID CONFIGURATION, page 19](#) for available RAID configurations.

STEP 5 CHOOSE RAID CONFIGURATION

The B260 M4 server integrates the LSI SAS3008 12G SAS RAID controller, which provides RAID 0/1 capability.

Caveats

- RAID configuration is possible if you have two identical drives. Otherwise, a JBOD configuration is supported.

STEP 6 CHOOSE ADAPTERS

The adapter offerings are:

■ Cisco Virtual Interface Cards (VICs)

Cisco developed 1200 Series and 1300 Series Virtual Interface Cards (VICs) to provide flexibility to create multiple NIC and HBA devices. The VICs also support adapter Fabric Extender and Virtual Machine Fabric Extender technologies. The VIC features are listed here:

- 1200 Series VICs enable advanced networking features including Netflow for network statistics, and DPDK, USNIC for low-latency computing applications.
- 1300 Series VICs include all of the 1200 Series features plus additional enhancements including network overlay offload support for NVGRE and VXLAN, and RoCE services.
- In addition, 1300 Series VICs support PCIe Gen 3.0 for greater bandwidth than 1200 Series VICs
- Two Converged Network Adapter (CNA) ports, supporting both Ethernet and FCoE
- Delivers 80 Gbps total I/O throughput to the server
 - VIC 1240 supports dual 4 x 10 Gbps Unified I/O ports
 - VIC 1340 supports dual 4x 10 Gbps Unified I/O ports or 2x40 (native) Gbps Unified I/O ports
- Creates up to 256 fully functional unique and independent PCIe adapters and interfaces (NICs or HBAs) without requiring single-root I/O virtualization (SR-IOV) support from operating systems or hypervisors
- Provides virtual machine visibility from the physical network and a consistent network operations model for physical and virtual servers
- Supports customer requirements for a wide range of operating systems and hypervisors

■ Cisco UCS Storage Accelerator Adapters

Cisco UCS Storage Accelerator adapters are designed specifically for the Cisco UCS B-series M4 blade servers and integrate seamlessly to allow improvement in performance and relief of I/O bottlenecks.



NOTE: For environments with 6100 Series Fabric Interconnects, you must configure only the VIC 1240/1280 adapters (1200 Series) and not 1340/1380 (1300 Series). From an I/O connectivity standpoint, configure only the VIC 1200 Series with the 6100 Series Fabric Interconnects.



NOTE: There are three slots on the server. One is a dedicated slot for the VIC 1340/1240 adapter only and the other two accommodate Cisco or Cisco Storage Accelerator adapters as well as other options. [Table 10](#) shows which adapters plug into each of the three slots. Only the VIC 1340 or 1240 adapter plugs into the VIC 1340/1240 adapter slot. All other adapters plug into the other two mezzanine adapter slots.



NOTE: You must have a B260 M4 configured with 2 CPUs to support cards that plug into either of the two mezzanine connectors. The VIC 1340 and 1240 adapters are supported on both 1- and 2-CPU configured systems.

Table 10 shows the supported adapters.

To help ensure that your operating system is compatible with the cards you have selected, please check the Hardware Compatibility List at this URL:

http://www.cisco.com/en/US/products/ps10477/prod_technical_reference_list.html

Choose an Adapter

The supported mezzanine adapters in the UCS B260 M4 are listed in *Table 10*.

Table 10 Supported Mezzanine Adapters

Product ID (PID)	PID Description	Connector
Virtual Interface Cards (VICs)		
UCSB-MLOM-40G-03 ¹	Cisco UCS VIC 1340 modular LOM for blade servers	Adapter 1
UCSB-VIC-M83-8P ¹	Cisco UCS VIC 1380 mezzanine adapter	Adapter 3
UCSB-MLOM-40G-01 ²	Cisco UCS VIC 1240 modular LOM for blade servers	Adapter 1
UCS-VIC-M82-8P ²	Cisco UCS VIC 1280 mezzanine adapter	Adapter 3
Cisco Storage Accelerators³		
UCSB-F-FIO-1600MS	UCS 1600 GB Fusion ioMemory3 SX Scale line for B-Series	Adapter 2 or Adapter 3
UCSB-F-FIO-1300MP	UCS 1300 GB Fusion ioMemory3 PX Performance line for B-Series	Adapter 2 or Adapter 3
UCSB-F-FIO-365M	Cisco UCS 365 GB MLC Fusion-io ioDrive2	Adapter 2 or Adapter 3
UCSB-F-FIO-785M	Cisco UCS 785GB MLC Fusion-io ioDrive2	Adapter 2 or Adapter 3
UCSB-F-LSI-400S	LSI 400GB SLC WarpDrive ⁴	Adapter 2 or Adapter 3
Port Expander Card for VIC Option		
UCSB-MLOM-PT-01	Cisco UCS Port Expander Card for VIC. This is a hardware option to enable an additional 4 ports of the VIC 1340 or VIC 1240, bringing the total capability of the VIC 1340 or VIC 1240 to dual 4 x 10 GbE	Adapter 2

Notes . . .

1. The VIC 1340/1380 are only supported with the 6200 Series Fabric Interconnects. They are not supported with the 6100 Series Fabric Interconnects.
2. The VIC 1240/1280 are supported with both the 6200 and 6100 Series Fabric Interconnects.
3. Do not mix Fusion io storage accelerator families. That is, do not mix “MP” or “MS” (ioMemory3) with “M” (ioDrive2) family cards.
4. The LSI 400 GB SLC WarpDrive has reached End of Sale status, but is still supported

“Adapter 1,” “Adapter 2,” and “Adapter 3” refer to the UCSM naming convention for the adapter slots (this document uses the UCSM naming convention). In the server BIOS and on the

motherboard, the corresponding slots are labeled as “mLOM,” “Mezz 1,” and “Mezz 2,” respectively. See [Table 11](#).

Table 11 Adapter Slot Naming and Bandwidth

Server BIOS and Motherboard Slot Naming	UCSM Slot Naming	Available Bandwidth
mLOM (VIC 1240 or VIC 1340 only)	Adapter 1	20 Gbps per Fabric Extender
Mezz1	Adapter 2	20 Gbps per Fabric Extender
Mezz2	Adapter 3	40 Gbps per Fabric Extender

Supported Configurations

[Table 12](#) and [Table 13](#) show the supported adapter combinations. The configuration rules are summarized as follows:

- Adapter slot 1 is dedicated for the VIC 1240 or VIC 1340 only. No other mezzanine card can fit in Adapter Slot 1.
- The Port Expander Card can only be selected if the VIC 1240 or VIC 1340 is also selected for the server.
- You must select at least one VIC or CNA. You may select up to two VICs or CNAs. However, you cannot mix a VIC and a CNA in the same server.
- You cannot select more than one VIC 1240 or VIC 1340. You cannot select more than one VIC 1280 or VIC 1380. A VIC 1240 and a VIC 1280 can be mixed in the same server. A VIC 1340 and VIC1380 can also be mixed.
- You can select up to two Storage Acceleration adapters. A Fusion-io adapter cannot be mixed with an LSI WarpDrive adapter in the same server.

Select an adapter combination according to [Table 12](#) or [Table 13](#).



NOTE: CPU 1 controls adapter slot 1, and CPU 2 controls adapter slots 2 and 3.

Table 12 Supported 1340 and 1380 Adapter¹ Combinations (for each B260 M4 blade)

Adapter Configurations			Fabric Extenders Aggregate Bandwidth			Fabric Interconnects		CPU Required
Adapter Slot 1	Adapter Slot 2	Adapter Slot 3	2 x 2208XP	2 x 2204XP	2 x 2104XP ²	2 x 61xx ²	2 x 62xx	
Two VICs (VIC 1340 + VIC 1380)								
VIC 1340	Port Expander Card	VIC 1380	160 Gb/s	80 Gb/s	not supported	not supported	62xx	2
VIC 1340	Cisco UCS Storage Accelerator (Fusion-io or LSI)	VIC 1380	120 Gb/s	60 Gb/s	not supported	not supported	62xx	2
VIC 1340	Not populated	VIC 1380	120 Gb/s	60 Gb/s	not supported	not supported	62xx	2
One VIC (VIC 1380)								
Not populated	Cisco UCS Storage Accelerator (Fusion-io or LSI)	VIC 1380	80 Gb/s	40 Gb/s	not supported	not supported	62xx	2
Not populated	Not populated	VIC 1380	80 Gb/s	40 Gb/s	not supported	not supported	62xx	2
One VIC (VIC 1340)								
VIC 1340	Port Expander Card	Cisco UCS Storage Accelerator (Fusion-io or LSI)	80 Gb/s	40 Gb/s	not supported	not supported	62xx	2
VIC 1340	Port Expander Card	Not populated	80 Gb/s	40 Gb/s	not supported	not supported	62xx	2

Table 12 Supported 1340 and 1380 Adapter¹ Combinations (for each B260 M4 blade) (continued)

Adapter Configurations			Fabric Extenders Aggregate Bandwidth			Fabric Interconnects		CPU's Required
Adapter Slot 1	Adapter Slot 2	Adapter Slot 3	2 x 2208XP	2 x 2204XP	2 x 2104XP ²	2 x 61xx ²	2 x 62xx	
Note: for the following configuration, do not mix a Fusion-io adapter with an LSI WarpDrive. Slots 2 and 3 must have identical types of storage cards.								
VIC 1340	Cisco UCS Storage Accelerator (Fusion-io or LSI)	Cisco UCS Storage Accelerator (Fusion-io or LSI)	40 Gb/s	20 Gb/s	not supported	not supported	62xx	2
VIC 1340	Cisco UCS Storage Accelerator (Fusion-io or LSI)	Not populated	40 Gb/s	20 Gb/s	not supported	not supported	62xx	2
VIC 1340	Not populated	Not populated	40 Gb/s	20 Gb/s	not supported	not supported	62xx	1

Notes . . .

1. In the server BIOS and on the motherboard, "Adapter 1," "Adapter 2," and "Adapter 3" are labeled as "mLOM," "Mezz 1," and "Mezz 2," respectively
2. Supported only through UCS Manager version 2.2(3a) and later.

Table 13 Supported 1240 and 1280 Adapter¹ Combinations (for each B260 M4 blade)

Adapter Configurations			Fabric Extenders Aggregate Bandwidth			Fabric Interconnects		CPU's Required
Adapter Slot 1	Adapter Slot 2	Adapter Slot 3	2 x 2208XP	2 x 2204XP	2 x 2104XP ²	2 x 61xx ²	2 x 62xx	
Two VICs (VIC 1240 + VIC 1280)								
VIC 1240	Port Expander Card	VIC 1280	160 Gb/s	80 Gb/s	40 Gb/s	61xx ²	62xx	2
VIC 1240	Cisco UCS Storage Accelerator (Fusion-io or LSI)	VIC 1280	120 Gb/s	60 Gb/s	40 Gb/s	61xx ²	62xx	2
VIC 1240	Not populated	VIC 1280	120 Gb/s	60 Gb/s	40 Gb/s	61xx ²	62xx	2
One VIC (VIC 1280)								
Not populated	Cisco UCS Storage Accelerator (Fusion-io or LSI)	VIC 1280	80 Gb/s	40 Gb/s	20 Gb/s	61xx ²	62xx	2

Table 13 Supported 1240 and 1280 Adapter¹ Combinations (for each B260 M4 blade) *(continued)*

Adapter Configurations			Fabric Extenders Aggregate Bandwidth			Fabric Interconnects		CPU's Required
Adapter Slot 1	Adapter Slot 2	Adapter Slot 3	2 x 2208XP	2 x 2204XP	2 x 2104XP ²	2 x 61xx ²	2 x 62xx	
Not populated	Not populated	VIC 1280	80 Gb/s	40 Gb/s	20 Gb/s	61xx ²	62xx	2
One VIC (VIC 1240)								
VIC 1240	Port Expander Card	Cisco UCS Storage Accelerator (Fusion-io or LSI)	80 Gb/s	40 Gb/s	20 Gb/s	61xx ²	62xx	2
VIC 1240	Port Expander Card	Not populated	80 Gb/s	40 Gb/s	20 Gb/s	61xx ²	62xx	2
Note: for the following configuration, do not mix a Fusion-io adapter with an LSI WarpDrive. Slots 2 and 3 must have identical types of storage cards.								
VIC 1240	Cisco UCS Storage Accelerator (Fusion-io or LSI)	Cisco UCS Storage Accelerator (Fusion-io or LSI)	40 Gb/s	20 Gb/s	20 Gb/s	61xx ²	62xx	2
VIC 1240	Cisco UCS Storage Accelerator (Fusion-io or LSI)	Not populated	40 Gb/s	20 Gb/s	20 Gb/s	61xx ²	62xx	2
VIC 1240	Not populated	Not populated	40 Gb/s	20 Gb/s	20 Gb/s	61xx ²	62xx	1

Notes . . .

1. In the server BIOS and on the motherboard, “Adapter 1,” “Adapter 2,” and “Adapter 3” are labeled as “mLOM,” “Mezz 1,” and “Mezz 2,” respectively
2. Supported only through UCS Manager version 2.2(3a) and later.

To check that your operating system is compatible with the adapter you have selected, please check the Hardware Compatibility List at this URL

http://www.cisco.com/en/US/products/ps10477/prod_technical_reference_list.html

STEP 7 ORDER A TRUSTED PLATFORM MODULE (OPTIONAL)

Trusted Platform Module (TPM) is a computer chip (microcontroller) that can securely store artifacts used to authenticate the platform (server). These artifacts can include passwords, certificates, or encryption keys. A TPM can also be used to store platform measurements that help ensure that the platform remains trustworthy. Authentication (ensuring that the platform can prove that it is what it claims to be) and attestation (a process helping to prove that a platform is trustworthy and has not been breached) are necessary steps to ensure safer computing in all environments.

The TPM ordering information is listed in [Table 14](#).

Table 14 Trusted Platform Module

Product ID (PID)	PID Description
UCSX-TPM1-001	Trusted Platform Module for UCS



NOTE: The module used in this server conforms to TPM v1.2/1.3, as defined by the Trusted Computing Group (TCG).

STEP 8 ORDER OPTIONAL KVM CABLE

The KVM cable provides a console connection into the server, providing a DB9 serial connector, a VGA connector for a monitor, and dual USB 2.0 ports for a keyboard and mouse. With this cable, you can create a direct connection to the operating system and the BIOS running on the server.

The KVM cable ordering information is listed in [Table 15](#).

Table 15 KVM Cable

Product ID (PID)	PID Description
37-1016-01	KVM Cable

Figure 4 KVM Cable

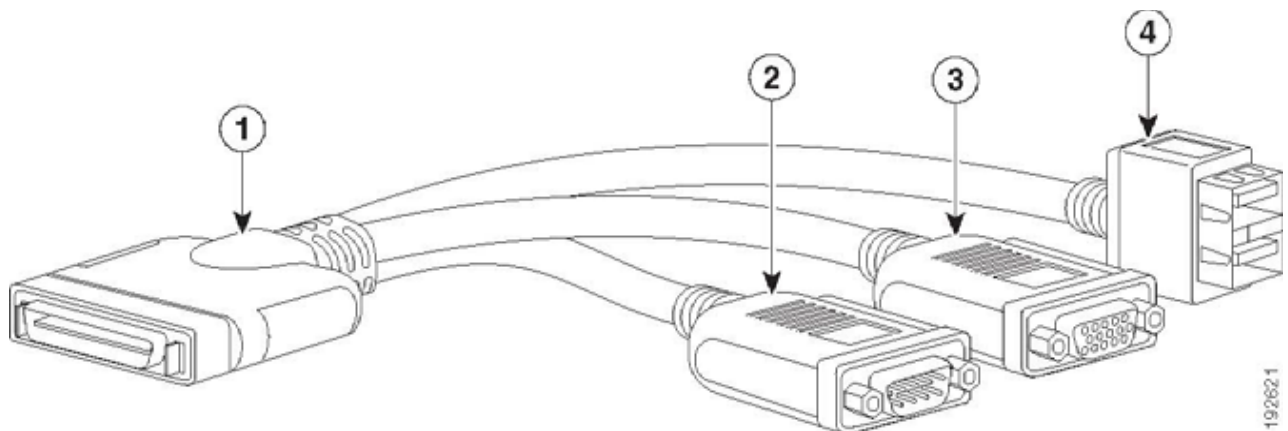

1	Connector (to server front panel)	3	VGA connector (for a monitor)
2	DB-9 serial connector	4	Two-port USB 2.0 connector (for a mouse and keyboard)

STEP 9 ORDER CISCO FLEXIBLE FLASH SECURE DIGITAL CARDS

Dual SDHC Flexible Flash card sockets are provided on the left side of the server, near the front.



NOTE: Dual card support (mirroring) is supported with UCS Manager 2.2.x and later.

The SDHC card ordering information is listed in [Table 16](#). Order one or two SD cards.

Table 16 Supported Configurations - Flexible Flash Card(s)

Product ID (PID)	PID Description
UCS-SD-32G-S	32GB SD Card module for UCS Servers

STEP 10 ORDER OPTIONAL INTERNAL USB 2.0 DRIVE

You may order one optional internal USB 2.0 drive. The USB drive ordering information is listed in [Table 17](#).

Table 17 USB 2.0 Drive

Product ID (PID)	PID Description
UCS-USBFLSH-S-4GB	4 GB Flash USB Drive (shorter) for all M3 servers
UCS-USBFLSHB-16GB	UCS Servers 16 GB Flash USB Drive



NOTE: A clearance of 0.950 inches (24.1 mm) is required for the USB device to be inserted and removed (see the following figure).

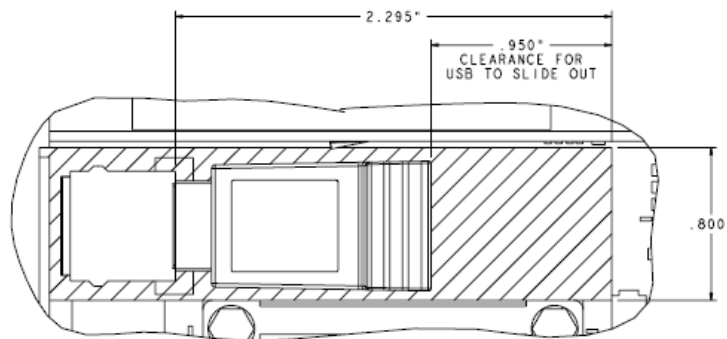

See [Figure 5 on page 40](#) for the location of the USB connector.



NOTE: When the Cisco USB key is purchased with a server, it is pre-installed into the internal USB port and held firmly in place with a clip to protect it from shock and vibration during shipment and transportation. This clip also prevents the USB key from undergoing shock and vibration during ongoing customer operational use.

STEP 11 CHOOSE OPERATING SYSTEM AND VALUE-ADDED SOFTWARE

Several software programs are available. Select as desired from [Table 18](#).

Table 18 Software (for 2-CPU servers)

PID Description	Product ID (PID)
Cisco One	
C1F2PUCSK9	Cisco ONE Foundation Perpetual UCS
C1A1PUCSK9	Cisco ONE Enterprise Cloud Perpetual UCS
C1UCS-OPT-OUT	Cisco One Data Center Compute Opt Out Option
Energy Management (JouleX)	
CEM-DC-PER	Perpetual License Key for Cisco Energy Management for DC
UCS Director	
CUIC-PHY-SERV-BM-U	Cisco UCS Director Resource Lic - 1 Phy Sevr node bare metal
CUIC-PHY-SERV-U	Cisco UCS Director Resource Lic - One physical Server node
CUIC-TERM	Acceptance of Cisco UCS Director License Terms
UCS Performance Manager	
UCS-PM-IE	UCS Performance Manager
UCS-PM-EE	UCS Performance Manager Express
EVAL-UCS-PM-IE	UCS Performance Manager - 90 days evaluation
EVAL-UCS-PM-EE	UCS Performance Manager Express - 90 days evaluation
Nexus 1000V for Hyper-V and vSphere	
N1K-VSG-UCS-BUN	Nexus 1000V Adv Edition for vSphere Paper License Qty 1
IMC Supervisor	
CIMC-SUP-B10	IMC Supervisor- Branch Mgt SW for C & E-Series up to 1K Svrs
CIMC-SUP-B02	IMC Supervisor- Branch Mgt SW for C & E-Series up to 250 Svrs
UCS Multi-Domain Manager	
UCS-MDMGR-100S	UCS Multi-Domain Manager (Central) Per Server License (100+)
UCS-MDMGR-50S	UCS Multi-Domain Manager (Central) Per Server License (50+)
UCS-MDMGR-1S	UCS Multi-Domain Manager (Central) Per Server License
UCS-MDMGR-10S	UCS Multi-Domain Manager (Central) Per Server License (10+)
UCS-MDMGR-1DMN	UCS Multi-Domain Manager (Central) Per Domain License
VMware vCenter	
VMW-VCS-STD-1A	VMware vCenter 6 Server Standard, 1 yr support required
VMW-VCS-STD-3A	VMware vCenter 6 Server Standard, 3 yr support required
VMW-VCS-STD-5A	VMware vCenter 6 Server Standard, 5 yr support required
VMW-VCS-FND-1A	VMware vCenter 6 Server Foundation (3 Host), 1 yr supp reqd
VMW-VCS-FND-3A	VMware vCenter 6 Server Foundation (3 Host), 3 yr supp reqd
VMW-VCS-FND-5A	VMware vCenter 6 Server Foundation (3 Host), 5 yr supp reqd
Microsoft Windows Server	
MSWS-12R2-DC2S	Windows Server 2012 R2 Datacenter (2 CPU/Unlimited VMs)

Table 18 Software (for 2-CPU servers) (continued)

PID Description	Product ID (PID)
MSWS-12-ST2S	Windows Server 2012 Standard (2 CPU/2 VMs)
MSWS-12-DC2S	Windows Server 2012 Datacenter (2 CPU/Unlimited VMs)
MSWS-12-ST2S-NS	Windows Server 2012 Standard (2 CPU/2 VMs) No Cisco SVC
MSWS-12R2-DC2S-NS	Windows Server 2012 R2 Datacenter (2 CPU/Unlim VM) No Cisco Svc
MSWS-12R2-ST2S	Windows Server 2012 R2 Standard (2 CPU/2 VMs)
MSWS-12-DC2S-NS	Windows Server 2012 Datacenter (2 CPU/Unlim VM) No Cisco Svc
MSWS-12R2-ST2S-NS	Windows Server 2012 R2 Standard (2 CPU/2 VMs) No Cisco SVC
Red Hat	
RHEL-2S2V-3A	Red Hat Enterprise Linux (1-2 CPU,1-2 VN); 3-Yr Support Req
RHEL-2S2V-1A	Red Hat Enterprise Linux (1-2 CPU,1-2 VN); 1-Yr Support Req
VMware	
VMW-VSP-EPL-5A	VMware vSphere 6 Ent Plus (1 CPU), 5-yr, Support Required
VMW-VSP-STD-1A	VMware vSphere 6 Standard (1 CPU), 1-yr, Support Required
VMW-VSP-STD-3A	VMware vSphere 6 Standard (1 CPU), 3-yr, Support Required
VMW-VSP-EPL-3A	VMware vSphere 6 Ent Plus (1 CPU), 3-yr, Support Required
VMW-VSP-EPL-1A	VMware vSphere 6 Ent Plus (1 CPU), 1-yr, Support Required
VMW-VSP-STD-5A	VMware vSphere 6 Standard (1 CPU), 5-yr, Support Required
SLES SAP	
SLES-SAP-2S2V-1S	SLES for SAP Apps (1-2 CPU, 1-2 VM); Priority 1-Yr SnS
SLES-SAP-2SUV-1S	SLES for SAP Apps (1-2 CPU, Unl VM); Priority 1-Yr SnS
SLES-SAP-2S2V-3S	SLES for SAP Apps (1-2 CPU, 1-2 VM); Priority 3-Yr SnS
SLES-SAP-2SUV-3S	SLES for SAP Apps (1-2 CPU, Unl VM); Priority 3-Yr SnS
SLES-SAP-2S2V-5S	SLES for SAP Apps (1-2 CPU, 1-2 VM); Priority 5-Yr SnS
SLES-SAP-2SUV-5S	SLES for SAP Apps (1-2 CPU, Unl VM); Priority 5-Yr SnS
SLES-SAP-2S2V-5A	SLES for SAP Apps (1-2 CPU, 1-2 VM); 5-Yr Support Reqd
SLES-SAP-2SUV-3A	SLES for SAP Apps (1-2 CPU, Unl VM); 3-Yr Support Reqd
SLES-SAP-2S2V-3A	SLES for SAP Apps (1-2 CPU, 1-2 VM); 3-Yr Support Reqd
SLES-SAP-2SUV-5A	SLES for SAP Apps (1-2 CPU, Unl VM); 5-Yr Support Reqd
SLES-SAP-2S2V-1A	SLES for SAP Apps (1-2 CPU, 1-2 VM); 1-Yr Support Reqd
SLES-SAP-2SUV-1A	SLES for SAP Apps (1-2 CPU, Unl VM); 1-Yr Support Reqd
SUSE	
SLES-2S2V-1A	SUSE Linux Enterprise Svr (1-2 CPU,1-2 VM); 1-Yr Support Req
SLES-2SUV-1A	SUSE Linux Enterprise Svr (1-2 CPU,Unl VM); 1-Yr Support Req
SLES-2S2V-3A	SUSE Linux Enterprise Svr (1-2 CPU,1-2 VM); 3-Yr Support Req
SLES-2SUV-3A	SUSE Linux Enterprise Svr (1-2 CPU,Unl VM); 3-Yr Support Req
SLES-2S2V-5A	SUSE Linux Enterprise Svr (1-2 CPU,1-2 VM); 5-Yr Support Req
SLES-2SUV-5A	SUSE Linux Enterprise Svr (1-2 CPU,Unl VM); 5-Yr Support Req
SLES-2S2V-1S	SUSE Linux Enterprise Svr (1-2 CPU,1-2 VM); Prio 1-Yr SnS

Table 18 Software (for 2-CPU servers) *(continued)*

PID Description	Product ID (PID)
SLES-2SUV-1S	SUSE Linux Enterprise Svr (1-2 CPU,Unl VM); Prio 1-Yr SnS
SLES-2S2V-3S	SUSE Linux Enterprise Svr (1-2 CPU,1-2 VM); Prio 3-Yr SnS
SLES-2SUV-3S	SUSE Linux Enterprise Svr (1-2 CPU,Unl VM); Prio 3-Yr SnS
SLES-2S2V-5S	SUSE Linux Enterprise Svr (1-2 CPU,1-2 VM); Prio 5-Yr SnS
SLES-2SUV-5S	SUSE Linux Enterprise Svr (1-2 CPU,Unl VM); Prio 5-Yr SnS
SLES-2S-HA-1S	SUSE Linux High Availability Ext (1-2 CPU); 1yr SnS
SLES-2S-HA-3S	SUSE Linux High Availability Ext (1-2 CPU); 3yr SnS
SLES-2S-HA-5S	SUSE Linux High Availability Ext (1-2 CPU); 5yr SnS
SLES-2S-GC-1S	SUSE Linux GEO Clustering for HA (1-2 CPU); 1yr SnS
SLES-2S-GC-3S	SUSE Linux GEO Clustering for HA (1-2 CPU); 3yr SnS
SLES-2S-GC-5S	SUSE Linux GEO Clustering for HA (1-2 CPU); 5yr SnS

STEP 12 CHOOSE OPERATING SYSTEM MEDIA KIT

Choose the optional operating system media listed in [Table 19](#).

Table 19 OS Media

Product ID (PID)	PID Description
RHEL-6	RHEL 6 Recovery Media Only (Multilingual)
MSWS-12-ST2S-RM	Windows Server 2012 Standard (2 CPU/2 VMs) Recovery Media
MSWS-12-DC2S-RM	Windows Server 2012 Datacenter (2 CPU/Unlimited VM) Rec Media
MSWS-12R2-ST2S-RM	Windows Server 2012 R2 Standard (2 CPU/2 VMs) Recovery Media
MSWS-12R2-DC2S-RM	Windows Server 2012 R2 Datacenter (2 CPU/Unlimited VM) Rec Media

STEP 13 CHOOSE SERVICE and SUPPORT LEVEL

A variety of service options are available, as described in this section.

Unified Computing Warranty, No Contract

If you have noncritical implementations and choose to have no service contract, the following coverage is supplied:

- Three-year parts coverage.
- Next business day (NBD) onsite parts replacement eight hours a day, five days a week.
- 90-day software warranty on media.
- Ongoing downloads of BIOS, drivers, and firmware updates.
- UCSM updates for systems with Unified Computing System Manager. These updates include minor enhancements and bug fixes that are designed to maintain the compliance of UCSM with published specifications, release notes, and industry standards.

SMARTnet for UCS

For support of the entire Unified Computing System, Cisco offers the Cisco SMARTnet for UCS Service. This service provides expert software and hardware support to help sustain performance and high availability of the unified computing environment. Access to Cisco Technical Assistance Center (TAC) is provided around the clock, from anywhere in the world.

For UCS blade servers, there is Smart Call Home, which provides proactive, embedded diagnostics and real-time alerts. For systems that include Unified Computing System Manager, the support service includes downloads of UCSM upgrades. The Cisco SMARTnet for UCS includes flexible hardware replacement options, including replacement in as little as two hours. There is also access to Cisco's extensive online technical resources to help maintain optimal efficiency and uptime of the unified computing environment. You can choose a desired service listed in [Table 20](#).

Table 20 Cisco SMARTnet for UCS Service

Service SKU	On Site?	Description
CON-PREM-B260M4	Yes	ONSITE 24X7X2 UCS Blade Module for B260/B460 M4
CON-OSP-B260M4	Yes	ONSITE 24X7X4 UCS Blade Module for B260/B460 M4
CON-OSE-B260M4	Yes	ONSITE 8X5X4 UCS Blade Module for B260/B460 M4
CON-OS-B260M4	Yes	ONSITE 8X5XNBD UCS Blade Module for B260/B460 M4
CON-S2P-B260M4	No	SMARTNET 24X7X2 UCS Blade Module for B260/B460 M4
CON-SNTP-B260M4	No	SMARTNET 24X7X4 UCS Blade Module for B260/B460 M4
CON-SNTE-B260M4	No	SMARTNET 8X5X4 UCS Blade Module for B260/B460 M4
CON-SNT-B260M4	No	SMARTNET 8X5XNBD UCS Blade Module for B260/B460 M4

SMARTnet for UCS Hardware Only Service

For faster parts replacement than is provided with the standard Cisco Unified Computing System warranty, Cisco offers the Cisco SMARTnet for UCS Hardware Only Service. You can choose from two levels of advanced onsite parts replacement coverage in as little as four hours. SMARTnet for UCS Hardware Only Service provides remote access any time to Cisco support professionals who can determine if a return materials authorization (RMA) is required. You can choose a service listed in [Table 21](#).

Table 21 SMARTnet for UCS Hardware Only Service

Service SKU	Service Level GSP	On Site?	Description
CON-UCW7-B260M4	UCW7	Yes	UC PLUS 24X7X40S UCS Blade Module for B260/B460 M4
CON-UCW5-B260M4	UCW5	Yes	UC PLUS 8X5XNBDOS UCS Blade Module for B260/B460 M4

Unified Computing Partner Support Service

Cisco Partner Support Service (PSS) is a Cisco Collaborative Services service offering that is designed for partners to deliver their own branded support and managed services to enterprise customers. Cisco PSS provides partners with access to Cisco's support infrastructure and assets to help them:

- Expand their service portfolios to support the most complex network environments
- Lower delivery costs
- Deliver services that increase customer loyalty

Partner Unified Computing Support Options enable eligible Cisco partners to develop and consistently deliver high-value technical support that capitalizes on Cisco intellectual assets. This helps partners to realize higher margins and expand their practice.

Partner Unified Computing Support Options are available to Cisco PSS partners. For additional information, see the following URL:

www.cisco.com/go/partnerucssupport

The two Partner Unified Computing Support Options include:

- Partner Support Service for UCS
- Partner Support Service for UCS Hardware Only

Partner Support Service for UCS provides hardware and software support, including triage support for third party software, backed by Cisco technical resources and level three support. See [Table 22](#).

Table 22 Partner Support Service for UCS

Service SKU	Service Level GSP	On Site?	Description
CON-PSJ1-B260M4	PSJ1	No	UCS SUPP PSS 8X5XNBD UCS Blade Module for B260/B460 M4
CON-PSJ2-B260M4	PSJ2	No	UCS SUPP PSS 8X5X4 UCS Blade Module for B260/B460 M4
CON-PSJ3-B260M4	PSJ3	No	UCS SUPP PSS 24X7X4 UCS Blade Module for B260/B460 M4
CON-PSJ4-B260M4	PSJ4	No	UCS SUPP PSS 24X7X2 UCS Blade Module for B260/B460 M4
CON-PSJ6-B260M4	PSJ6	Yes	UCS SUPP PSS 8x5x4 Onsite UCS Blade Module for B260/B460 M4
CON-PSJ7-B260M4	PSJ7	Yes	UCS SUPP PSS 24X7X4 Onsite UCS Blade Module for B260/B460 M4
CON-PSJ8-B260M4	PSJ8	Yes	UCS SUPP PSS 24X7X2 Onsite UCS Blade Module for B260/B460 M4

Partner Support Service for UCS Hardware Only provides customers with replacement parts in as little as two hours. See [Table 23](#).

Table 23 Partner Support Service for UCS (Hardware Only)

Service SKU	Service Level GSP	On Site?	Description
CON-PSW2-B260M4	PSW2	No	UCS W PL PSS 8X5X4 UCS Blade Module for B260/B460 M4
CON-PSW3-B260M4	PSW3	No	UCS W PL PSS 24X7X4 UCS Blade Module for B260/B460 M4
CON-PSW4-B260M4	PSW4	No	UCS W PL PSS 24X7X2 UCS Blade Module for B260/B460 M4
CON-PSW6-B260M4	PSW6	Yes	UCS HW ONLY PSS 8x5x4 Onsite UCS Blade Module for B260/B460 M4
CON-PSW7-B260M4	PSW7	Yes	UCS HW ONLY PSS 24x7x4 Onsite UCS Blade Module for B260/B460 M4

Cisco Combined Services

Combined Services makes it easier to purchase and manage required services under one contract. SMARTnet services for UCS help increase the availability of your vital data center infrastructure and realize the most value from your unified computing investment. The more benefits you realize from the Cisco Unified Computing System (Cisco UCS), the more important the technology becomes to your business. These services allow you to:

- Optimize the uptime, performance, and efficiency of your UCS
- Protect your vital business applications by rapidly identifying and addressing issues
- Strengthen in-house expertise through knowledge transfer and mentoring
- Improve operational efficiency by allowing UCS experts to augment your internal staff resources
- Enhance business agility by diagnosing potential issues before they affect your operations

Unified Computing Drive Retention Service

With the Cisco Unified Computing Drive Retention (UCDR) Service, you can obtain a new disk drive in exchange for a faulty drive without returning the faulty drive. In exchange for a Cisco replacement drive, you provide a signed Certificate of Destruction (CoD) confirming that the drive has been removed from the system listed, is no longer in service, and has been destroyed.

Sophisticated data recovery techniques have made classified, proprietary, and confidential information vulnerable, even on malfunctioning disk drives. The UCDR service enables you to retain your drives and ensures that the sensitive data on those drives is not compromised, which reduces the risk of any potential liabilities. This service also enables you to comply with regulatory, local, and federal requirements.

If your company has a need to control confidential, classified, sensitive, or proprietary data, you might want to consider one of the Drive Retention Services listed in [Table 24](#), [Table 25](#), or [Table 26](#).



NOTE: Cisco does not offer a certified drive destruction service as part of this service.

Table 24 Drive Retention Service Options

Service Description	Service Program Name	Service Level GSP	Service Level	Product ID (PID)
SMARTnet for UCS Service with Drive Retention	UCS DR	UCSD7	24x7x4 Onsite	CON-UCSD7-B260M4
		UCSD5	8x5xNBD Onsite	CON-UCSD5-B260M4
SMARTnet for UCS HW ONLY+Drive Retention	UCS HW+DR	UCWD7	24x7x4 Onsite	CON-UCWD7-B260M4
		UCWD5	8x5xNBD Onsite	CON-UCWD5-B260M4

Table 25 Drive Retention Service Options for Partner Support Service

Service Description	Service Level GSP	Service Level	Product ID (PID)
Partner Support Service for UCS Drive Retention	PSJD6	8x5x4 Onsite	CON-PSJD6-B260M4
	PSJD7	24x7x4 Onsite	CON-PSJD7-B260M4

Table 26 Drive Retention Service Options for Partner Support Service (Hardware Only)

Service Description	Service Level GSP	Service Level	Product ID (PID)
Partner Support Service for UCS Drive Retention Hardware only	PSWD6	8x5x4 Onsite	CON-PSWD6-B260M4
	PSWD7	24x7x4 Onsite	CON-PSWD7-B260M4

For more service and support information, see the following URL:

http://www.cisco.com/en/US/services/ps2961/ps10312/Unified_Computing_Services_Overview.pdf

For a complete listing of available services for Cisco Unified Computing System, see this URL:

http://www.cisco.com/en/US/products/ps10312/serv_group_home.html

SUPPLEMENTAL MATERIAL

Motherboard

A photo of the top view of the B260 M4 server with the cover removed is shown in [Figure 5](#).

Figure 5 B260 M4 Top View (cover off)



A drawing of the top view of the B260 M4 server with the cover removed is shown in [Figure 5](#).

Figure 6 B260 M4 Top View (cover off)

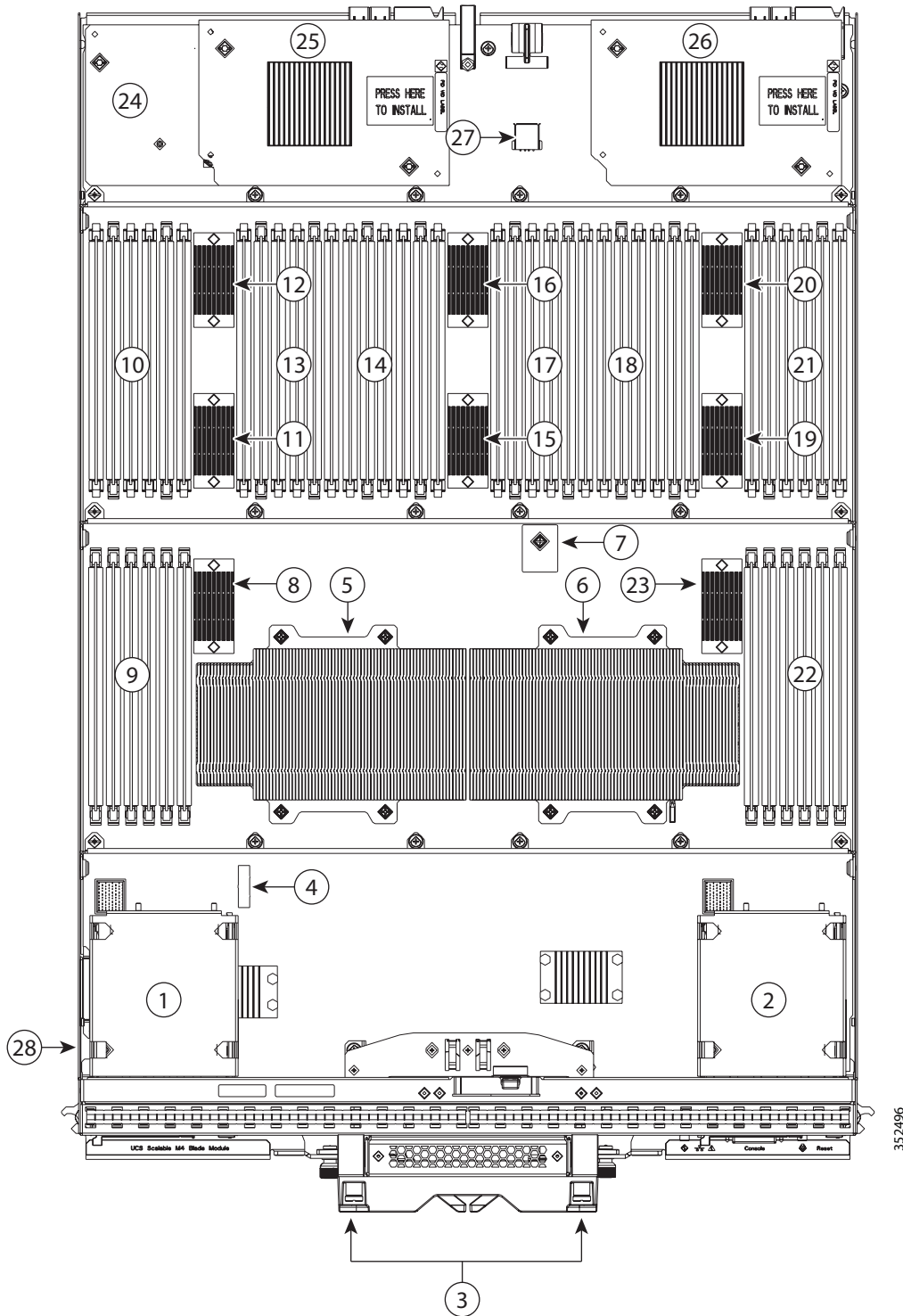

1	Drive bay 1	15	Memory buffer for subchannels G and H
2	Drive bay 2	16	Memory buffer for subchannels I and J
3	UCS scalability terminator	17	DIMM slots I1-I3 and J1-J3
4	CMOS battery	18	DIMM slots N1-N3 and M1-M3
5	CPU 1 (under heat sink)	19	Memory buffer for subchannels M and N
6	CPU 2 (under heat sink)	20	Memory buffer for subchannels I and J
7	Trusted Platform Module (TPM)	21	DIMM slots K1-K3 and L1-L3
8	Memory buffer for subchannels A and B	22	DIMM slots O1-O3 and P1-P3
9	DIMM slots A1-A3 and B1-B3	23	Memory buffer for subchannels O and P
10	DIMM slots C1-C3 and D1-D3	24	mLOM card This slot is shown in Cisco UCS manager as "Adapter 1" but the BIOS lists it as "mLOM." The VIC 1340/1240 is a type of adapter with a specific footprint that can only be used in this slot.
11	Memory buffer for DIMM subchannels C and D	25	Adapter card This slot is shown in Cisco UCS manager as "Adapter 2" but the BIOS lists it as "Mezz 1." Mixing adapter types is supported.
12	Memory buffer for subchannels E and F	26	Adapter card This slot is shown in Cisco UCS manager as "Adapter 3" but the BIOS lists it as "Mezz 2." Mixing adapter types is supported.
13	DIMM slots E1-E3 and F1-F3	27	Internal USB connector
14	DIMM slots G1-G3 and H1-H3	28	Flexible Flash card locations (2)

DIMM and CPU Layout

The DIMM and CPU layout is shown in [Figure 7](#).

Figure 7 DIMM and CPU Layout

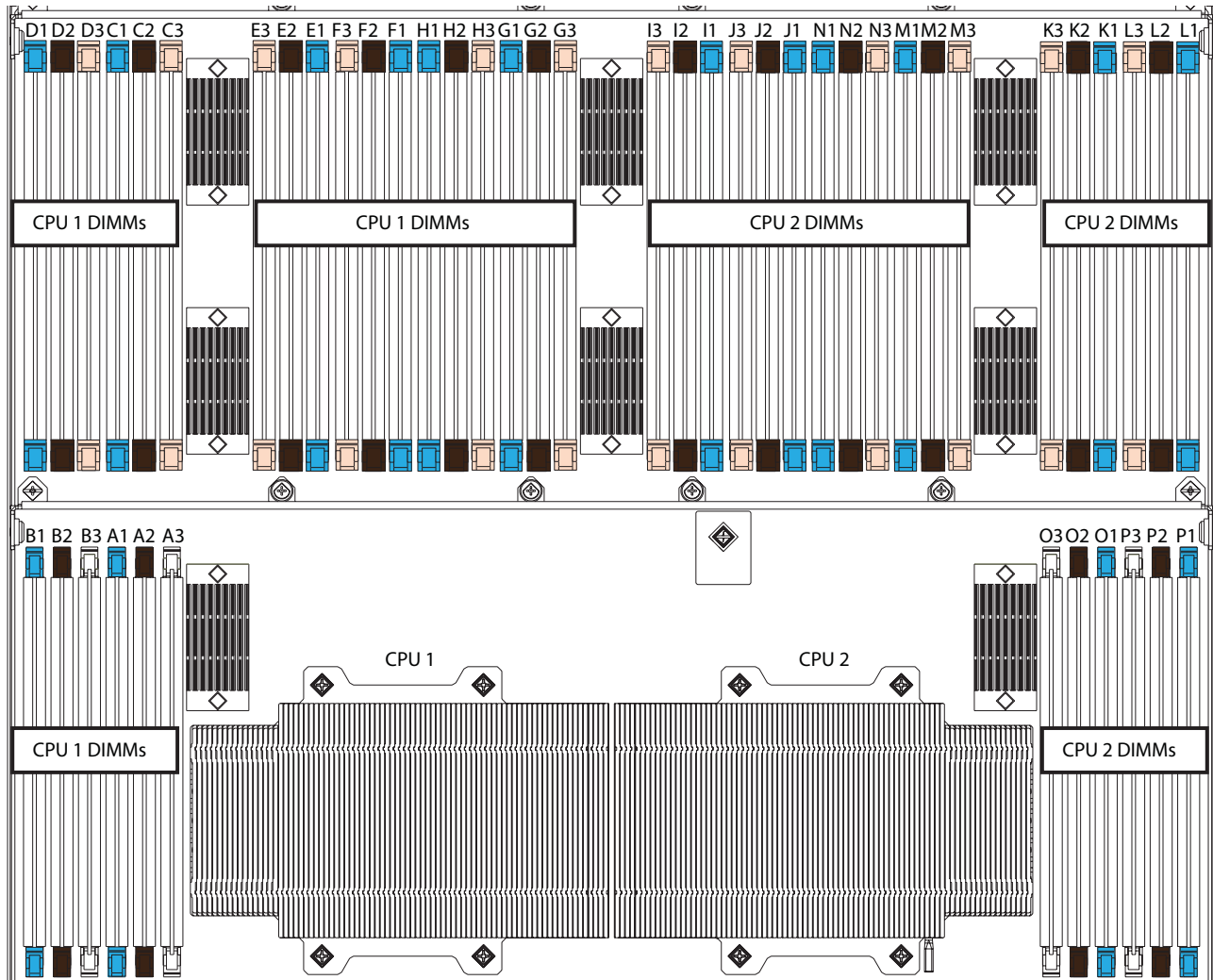

Each CPU controls four memory channels, and each memory channel controls two subchannels each through individual memory buffers placed around the motherboard (shown as black rectangles on [Figure 7](#)). Each subchannel controls 3 DIMMs as follows (refer also to [Figure 3 on page 12](#)):

- CPU 1 subchannels A through H and DIMMs controlled:
 - A1 (blue DIMM slot), A2 (black DIMM slot), A3 (white DIMM slot)
 - B1 (blue DIMM slot), B2 (black DIMM slot), B3 (white DIMM slot)
 - C1 (blue DIMM slot), C2 (black DIMM slot), C3 (ivory DIMM slot)
 - D1 (blue DIMM slot), D2 (black DIMM slot), D3 (ivory DIMM slot)
 - E1 (blue DIMM slot), E2 (black DIMM slot), E3 (ivory DIMM slot)

- F1 (blue DIMM slot), F2 (black DIMM slot), F3 (ivory DIMM slot)
- G1 (blue DIMM slot), G2 (black DIMM slot), G3 (ivory DIMM slot)
- H1 (blue DIMM slot), H2 (black DIMM slot), H3 (ivory DIMM slot)
- CPU 2 subchannels I through P and DIMMs controlled:
 - I1 (blue DIMM slot), I2 (black DIMM slot), I3 (ivory DIMM slot)
 - J1 (blue DIMM slot), J2 (black DIMM slot), J3 (ivory DIMM slot)
 - K1 (blue DIMM slot), K2 (black DIMM slot), K3 (ivory DIMM slot)
 - L1 (blue DIMM slot), L2 (black DIMM slot), L3 (ivory DIMM slot)
 - M1 (blue DIMM slot), M2 (black DIMM slot), M3 (ivory DIMM slot)
 - N1 (blue DIMM slot), N2 (black DIMM slot), N3 (ivory DIMM slot)
 - O1 (blue DIMM slot), O2 (black DIMM slot), O3 (white DIMM slot)
 - P1 (blue DIMM slot), P2 (black DIMM slot), P3 (white DIMM slot)

Memory Population Recommendations

See [Table 5 on page 13](#) for information on DIMM population guidelines.

When considering the memory configuration of your server, you should observe the following:

- Your selected CPU(s) can have some effect on performance. All CPUs in the server must be of the same type.
- Performance degradation can result from unevenly populating DIMMs between CPUs

Memory Mixing Guidelines

For the most part, it is recommended that all DIMMs that are installed be of the same type and size. See [Table 27](#) for guidelines about where DIMM sizes can be mixed.

Table 27 DIMM Mixing

Identical DIMMs or Mixed DIMMs	Qty of 2x8GB DIMM kits (UCS-MR-2X082RY-E)	Qty of 2x16GB DIMM kit (UCS-MR-2X162RY-E)	Qty of 2x32GB DIMM kit (UCS-ML-2X324RY-E)	Qty of 2x64GB DIMM kit (UCS-ML-2X648RY-E)	Total Memory Capacity
Mixed	8 (16 DIMMs)	8 (16 DIMMs)			384 GB
Mixed	8 (16 DIMMs)	16 (32 DIMMs)			640 GB
Mixed	16 (32 DIMMs)	8 (16 DIMMs)			512 GB
Mixed			8 (16 DIMMs)	8 (16 DIMMs)	1536 GB
Mixed			8 (16 DIMMs)	16 (32 DIMMs)	2560 GB
Mixed			16 (32 DIMMs)	8 (16 DIMMs)	2048 GB

Upgrade and Servicing-Related Parts

This section lists the upgrade and servicing-related parts you may need during the life of your server. Some of these parts are configured with every server or with every UCS 5108 blade server chassis, and some may be ordered when needed or may be ordered and kept on hand as spares for future use. See [Table 28](#).

Table 28 Upgrade and Servicing-related Parts for UCS B260 M4 Server

Spare Product ID (PID)	Description
N20-BBLKD=	2.5-inch HDD Blanking Panel ¹
UCSB-HS-01-EX=	CPU Heat Sink for UCS B260 M4 and B460 M4 ¹
UCS-CPU-LPCVR=	CPU load plate dust cover (for unpopulated CPU sockets)
N20-MBLIBATT=	Replacement Lithium Battery for Server Motherboard (CR2032) ¹
N20-BKVM=	KVM local IO cable for UCS servers console port ²
UCS-CPU-EP-PNP=	Pick n place CPU tools for M3/EP and M4/EX CPUs ³
UCS-CPU-GREASE3=	Thermal grease for M4/EX heat sink seal ³
UCSX-HSCK=	UCS Processor Heat Sink Cleaning Kit (when replacing a CPU) ³
UCS-SD-32G-S=	32 GB SD card module for UCS servers ⁴
UCS-USBFLSH-S-4GB=	4 GB Flash USB drive (shorter)
UCS-USBFLSHB-16GB=	UCS Servers 16GB Flash USB Drive

Notes . . .

1. This part is included/configured with your UCS server (in some cases, as determined by the configuration of your server).
2. This part is included/configured with the UCS 5108 blade server chassis.
3. This part is included with the purchase of each optional or spare CPU processor kit.
4. Only half the capacity of the 32 GB SD card is available with this server

Drive and Blade Server Blanking Panels

A drive blanking panel (N20-BBLKD=) must be installed if you remove a disk drive from a UCS server. These panels are required to maintain system temperatures at safe operating levels, and to keep dust away from system components.

Replacing a CPU (with CPU heat sink)

Instructions for replacing a CPU and heat sink can be found at the following link:

http://www.cisco.com/c/en/us/td/docs/unified_computing/ucs/hw/blade-servers/B260M4.html

Motherboard Lithium Battery

You can order a replacement motherboard battery. Installation instructions are found at this link:

http://www.cisco.com/c/en/us/td/docs/unified_computing/ucs/hw/blade-servers/B260M4.html

CPU Removal and Installation (“pick n place”) Tool Set

The Pick n Place tool set is used to install a CPU in its socket without damage. It must be used each time a CPU is installed in the server.

Instructions for using this tool set are found at the following link:

http://www.cisco.com/c/en/us/td/docs/unified_computing/ucs/hw/blade-servers/B260M4.html



NOTE: When you purchase a spare CPU, the Pick n Place Toolkit is included.

Thermal Grease (with syringe applicator) for CPU to Heatsink Seal

Thermal grease must be applied to the top of the CPU where it comes in contact with the heat sink. Instructions for applying thermal grease are found at:

http://www.cisco.com/c/en/us/td/docs/unified_computing/ucs/hw/blade-servers/B260M4.html



CAUTION:
DO NOT use thermal grease available for purchase at any commercial electronics store. If these instructions are not followed, the CPU may overheat and be destroyed.



NOTE: When you purchase a spare CPU, the thermal grease with syringe applicator is included.

CPU Heat Sink Cleaning Kit

The cleaning kit is used to remove the existing thermal compound from the bottom of the heat sink during a CPU replacement process. Instructions for cleaning are found at the following link:

http://www.cisco.com/c/en/us/td/docs/unified_computing/ucs/hw/blade-servers/B260M4.html



NOTE: When you purchase a spare CPU, the CPU cleaning kit is included.

Network Connectivity

This section shows how the supported adapter card configurations for the B260 M4 connect to the Fabric Extender modules in the 5108 blade server chassis.

There are three configurable adapter slots on the B260 M4. One slot supports only the VIC 1340/1240 adapter, and two additional slots accommodate Cisco adapters, as well as Cisco UCS Storage Accelerator adapters. [Table 12 on page 24](#) shows supported adapter configurations. You must install at least one VIC or CNA adapter in one of the three adapter slots.

“Adapter 1,” “Adapter 2,” and “Adapter 3” refer to the UCSM naming convention for the adapter slots (this document uses the UCSM naming convention). In the server BIOS and on the motherboard, the corresponding slots are labeled as “mLOM,” “Mezz 1,” and “Mezz 2,” respectively. See [Table 29](#).

Table 29 Adapter Slot Naming

Server BIOS and Motherboard Slot Naming	UCSM Slot Naming	Available Bandwidth
mLOM (VIC 1340/1240 only)	Adapter 1	20 Gbps per Fabric Extender
Mezz1	Adapter 2	20 Gbps per Fabric Extender
Mezz2	Adapter 3	40 Gbps per Fabric Extender

Total bandwidth is a function of the Fabric Extender, the adapter, and the adapter slot, as shown in [Table 30](#) and [Table 31](#).

Table 30 Maximum Bandwidth Using Dual Fabric Extenders (FEXs)

FEX Model	Maximum Bandwidth Using Dual FEXs
2208XP	160 Gb
2204XP	160 Gb
2104XP	40 Gb

Table 31 Maximum Bandwidth for Each of the Three Adapter Slots

Adapter Slot	Maximum Bandwidth Using Dual FEXs
VIC 1340/1240 (Adapter 1) slot	40 Gb
Adapter 2 Slot	40 Gb
Adapter 3 Slot	80 Gb

Figure 8 shows the configuration for maximum bandwidth, where the following ports are routed to Fabric Extender Modules A and B inside the 5108 blade server chassis:

- Two 2 x 10G KR ports from the VIC 1340/1240 adapter
- Two 2 x 10G KR ports from the Port Expander
- Two 4 x 10G KR ports from the VIC 1380/1280 adapter

The resulting aggregate bandwidth is 160 Gb (80 Gb to each Fabric Extender).

Figure 8 UCS B260 M4 Connections to the Fabric Extenders

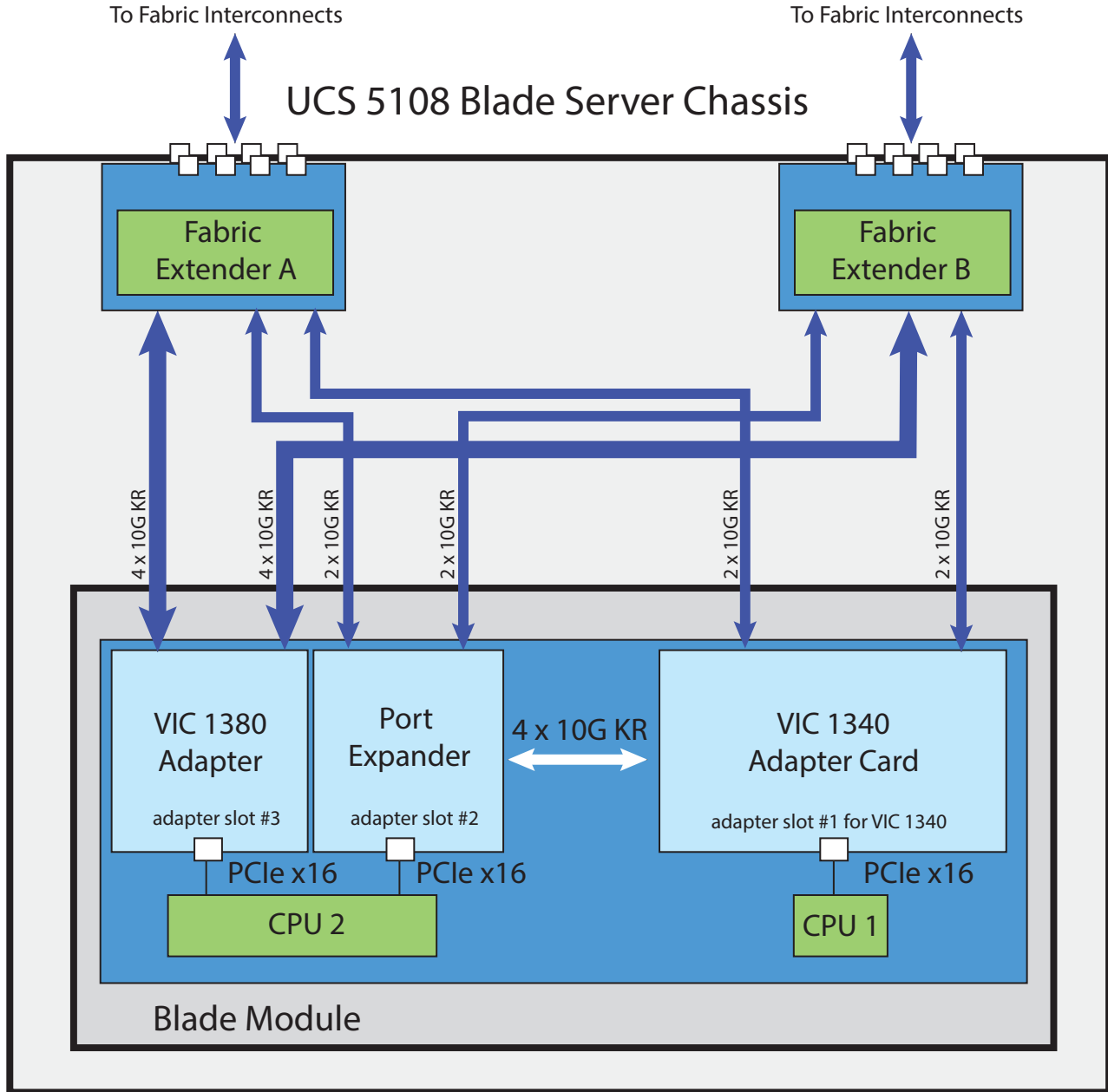

VIC 1340/1240 and Port Expander

Adapter slot 1 is dedicated to the VIC 1340/1240 adapter, and no other adapter card can be installed in this slot. There are two groups of four ports on the VIC 1340/1240:

- Two ports of the first group and two ports of the second group are wired through the UCS 5108 Blade Server chassis to Fabric Extender A and Fabric Extender B.
- The other two ports of each group are wired to adapter slot 2. The VIC 1340/1240 adapter senses the type of adapter installed in adapter slot 2. If a Port Expander is installed in adapter slot 2, the four 10G KR ports between the adapters are used for port expansion; otherwise they are unused.

With the Port Expander installed, there are up to eight (depending on the Fabric Extender installed) 10 Gb network interfaces, as represented in [Figure 9](#).

Figure 9 VIC 1340/1240 Connectivity

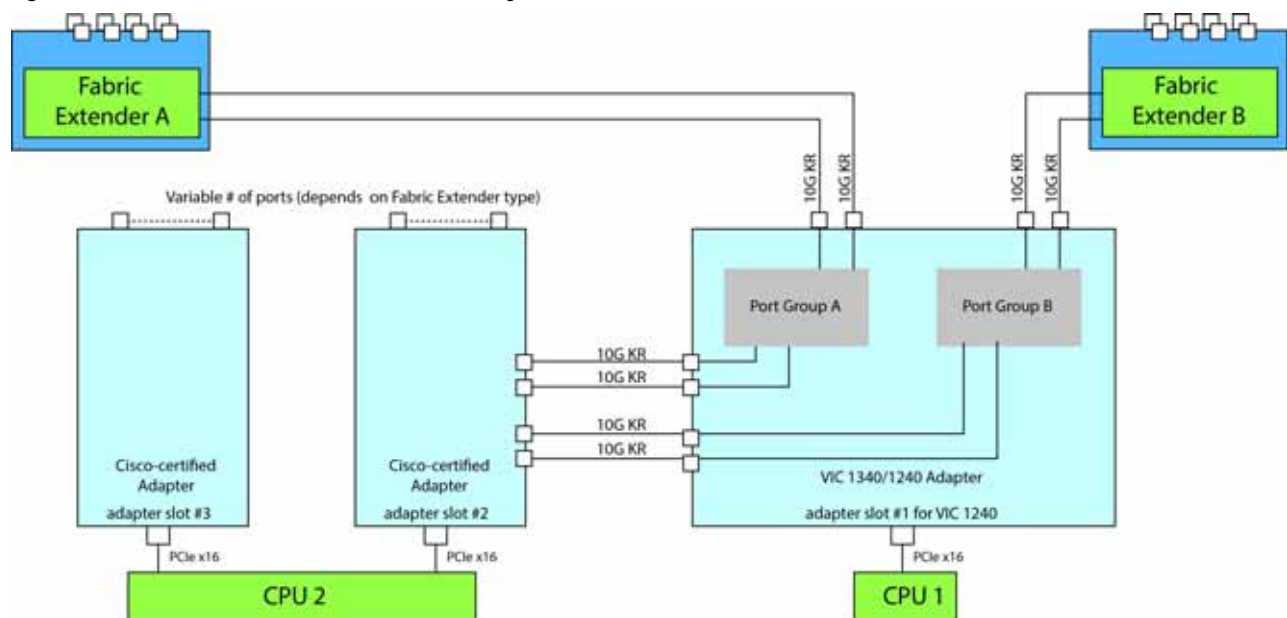

Connectivity Using the Cisco UCS 2208XP/2204XP Fabric Extender

The connectivity options shown in *Figure 10* through *Figure 19* are summarized in *Table 32*.

Table 32 Supported Adapter¹ Combinations Using the 2208XP/2204XP FEX

Adapter Slot 1	Adapter Slot 2	Adapter Slot 3	Total Available Bandwidth
			2 x 2208XP/ 2 x 2204XP
VIC 1340/1240	Port Expander Card	VIC 1380/1280	160/80 Gb <i>Figure 10 on page 53</i>
VIC 1340/1240	Cisco UCS Storage Accelerator	VIC 1380/1280	120/60 Gb <i>Figure 11 on page 53</i>
VIC 1340/1240	Not populated	VIC 1380/1280	120/60 Gb <i>Figure 12 on page 54</i>
Not populated	Cisco UCS Storage Accelerator	VIC 1380/1280	80/40 Gb <i>Figure 13 on page 54</i>
Not populated	Not populated	VIC 1380/1280	80/40 Gb <i>Figure 14 on page 55</i>
VIC 1340/1240	Port Expander Card	Cisco UCS Storage Accelerator	80/40 Gb <i>Figure 15 on page 55</i>
VIC 1340/1240	Port Expander Card	Not populated	80/40 Gb <i>Figure 16 on page 56</i>
Note: for the following configuration, do not mix a Cisco Storage Accelerator with an LSI WarpDrive. Slots 2 and 3 must have identical types of storage cards.			
VIC 1340/1240	Cisco UCS Storage Accelerator	Cisco UCS Storage Accelerator	40/20 Gb <i>Figure 17 on page 56</i>
VIC 1340/1240	Cisco UCS Storage Accelerator	Not populated	40/20 Gb <i>Figure 18 on page 57</i>
VIC 1340/1240	Not populated	Not populated	40/20 Gb <i>Figure 19 on page 57</i>

Notes . . .

1. In the server BIOS and on the motherboard, “Adapter 1,” “Adapter 2,” and “Adapter 3” are labeled as “mLOM,” “Mezz 1,” and “Mezz 2,” respectively

In *Figure 10*, two ports from the VIC 1340/1240 are channeled to Fabric Extender A and two are channeled to Fabric Extender B. The Port Expander Card for the VIC 1340/1240 installed in adapter slot 2 acts as a pass-through device, channeling two ports to each of the Fabric Extenders. In addition, the VIC 1380/1280 channels four ports to each Fabric Extender. The result is 80 Gb of bandwidth to each Fabric Extender.

Figure 10 VIC 1340/1240, Port Expander in adapter slot 2, and VIC 1380/1280 in adapter slot 3

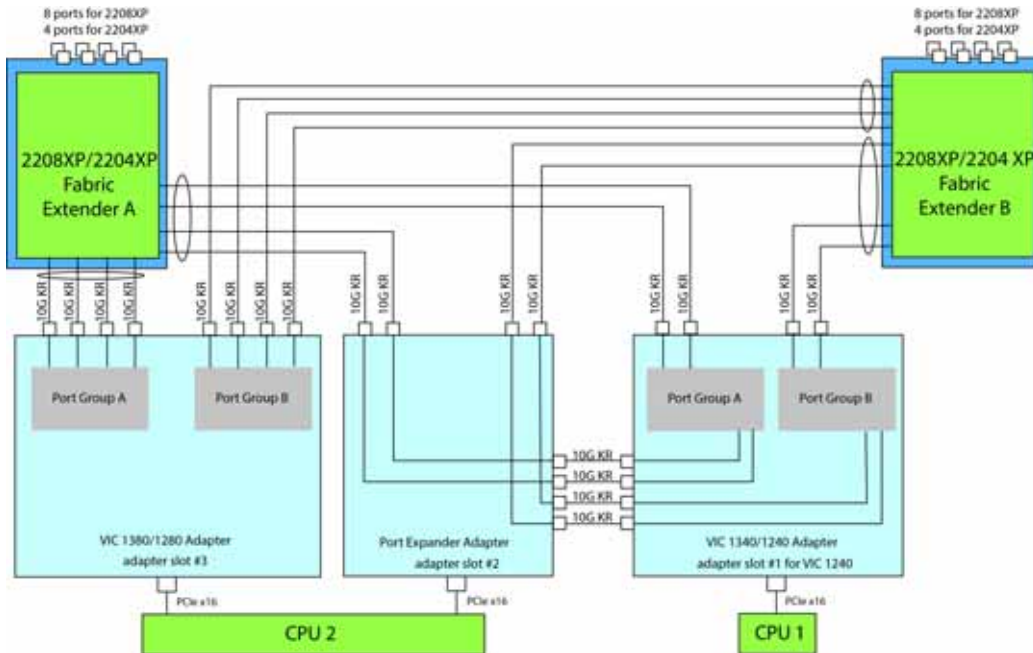

In *Figure 11*, two ports from the VIC 1340/1240 are channeled to Fabric Extender A and two are channeled to Fabric Extender B. A Cisco UCS Storage Accelerator adapter is installed in slot 2, but provides no network connectivity. The VIC 1380/1280 installed in adapter slot 3 channels four ports to each of the Fabric Extenders. The result is 60 Gb of bandwidth to each Fabric Extender.

Figure 11 VIC 1340/1240, Cisco UCS SA adapter slot 2, and VIC 1380/1280 adapter slot 3

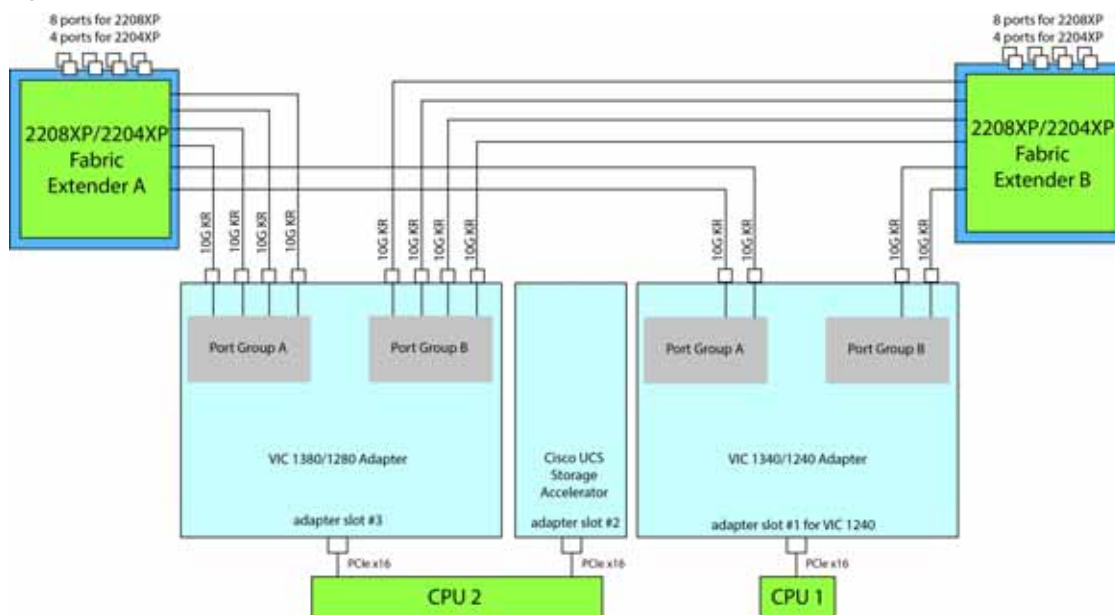

In *Figure 12*, two ports from the VIC 1340/1240 are channeled to Fabric Extender A and two are channeled to Fabric Extender B. Adapter slot 2 is empty. The VIC 1380/1280 installed in adapter slot 3 channels four ports to each of the Fabric Extenders. The result is 60 Gb of bandwidth to each Fabric Extender.

Figure 12 VIC 1340/1240 and VIC 1380/1280 (adapter slot 2 empty)

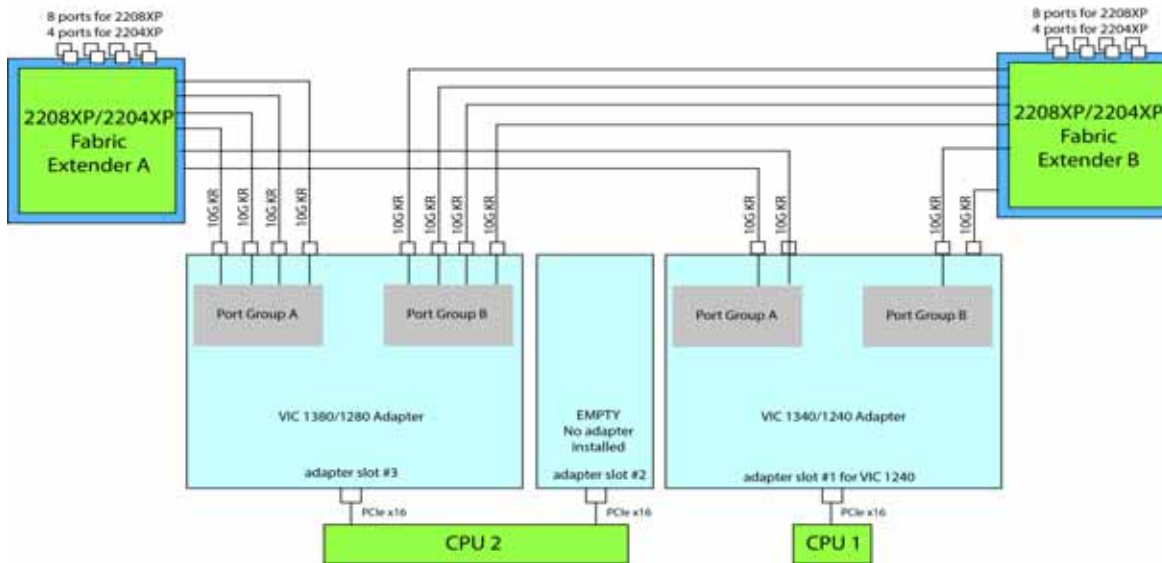

In *Figure 13*, no VIC 1340/1240 is installed. A Cisco UCS Storage Accelerator adapter is installed in slot 2, but provides no network connectivity. The VIC 1380/1280 installed in adapter slot 3 channels four ports to each of the Fabric Extenders. The result is 40 Gb of bandwidth to each Fabric Extender.

Figure 13 No VIC 1340/1240 installed, UCS Storage Accelerator in slot 2 and VIC 1380/1280 in slot 3

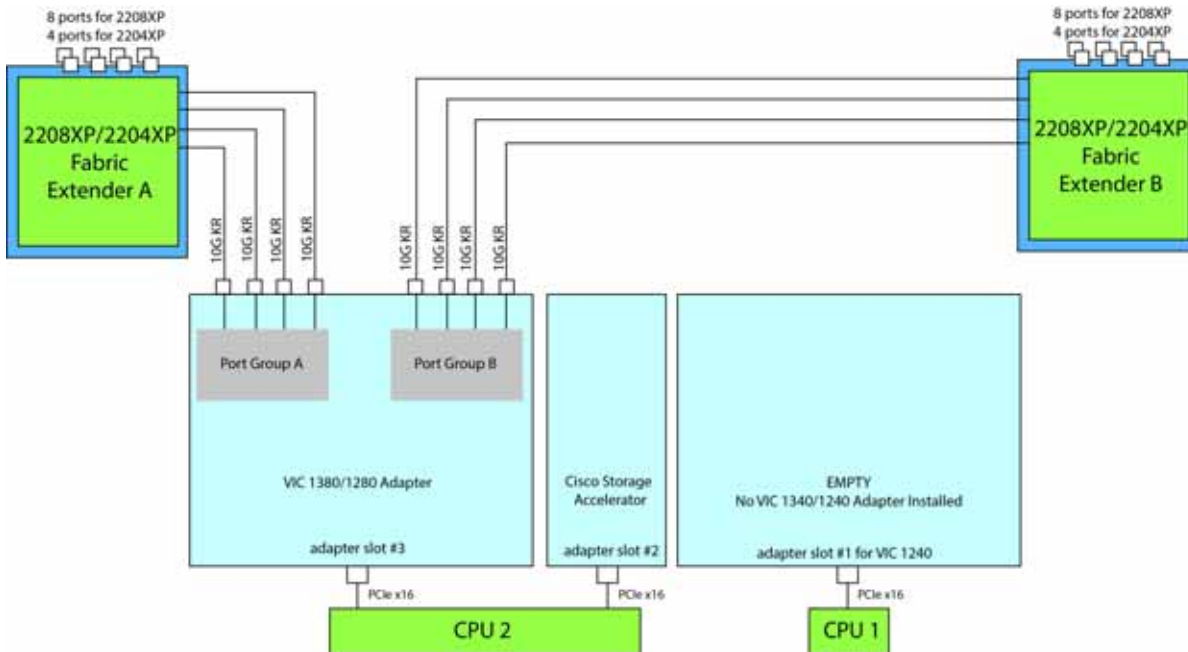

In *Figure 14*, no VIC 1340/1240 is installed. Adapter 2 slot is also not occupied. The VIC 1380/1280 installed in adapter slot 3 channels four ports to each of the Fabric Extenders. The result is 40 Gb of bandwidth to each Fabric Extender.

Figure 14 No VIC 1340/1240 installed, no adapter installed in slot 2, and VIC 1380/1280 in slot 3

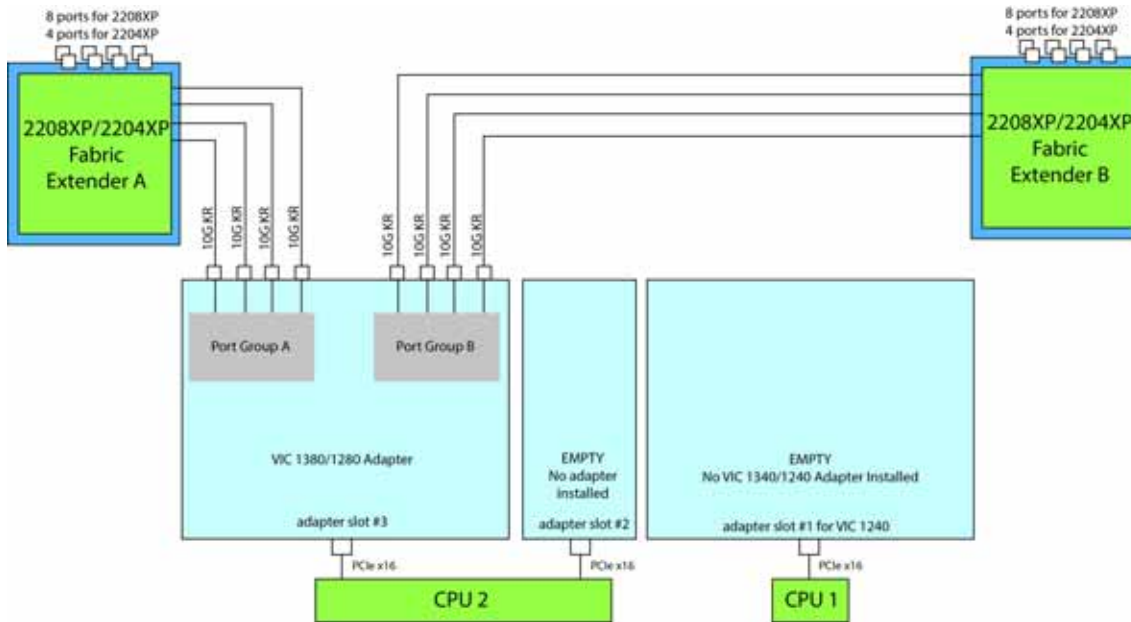

In *Figure 15*, two ports from the VIC 1340/1240 are channeled to Fabric Extender A and two are channeled to Fabric Extender B. The Port Expander Card installed in adapter slot 2 acts as a pass-through device, channeling two ports to each of the Fabric Extenders. A Cisco UCS storage accelerator is installed in slot 3, but provides no network connectivity. The result is 40 Gb of bandwidth to each Fabric Extender.

Figure 15 VIC 1340/1240 and Port Expander in Adapter Slot 2 with UCS storage accelerator in slot 3

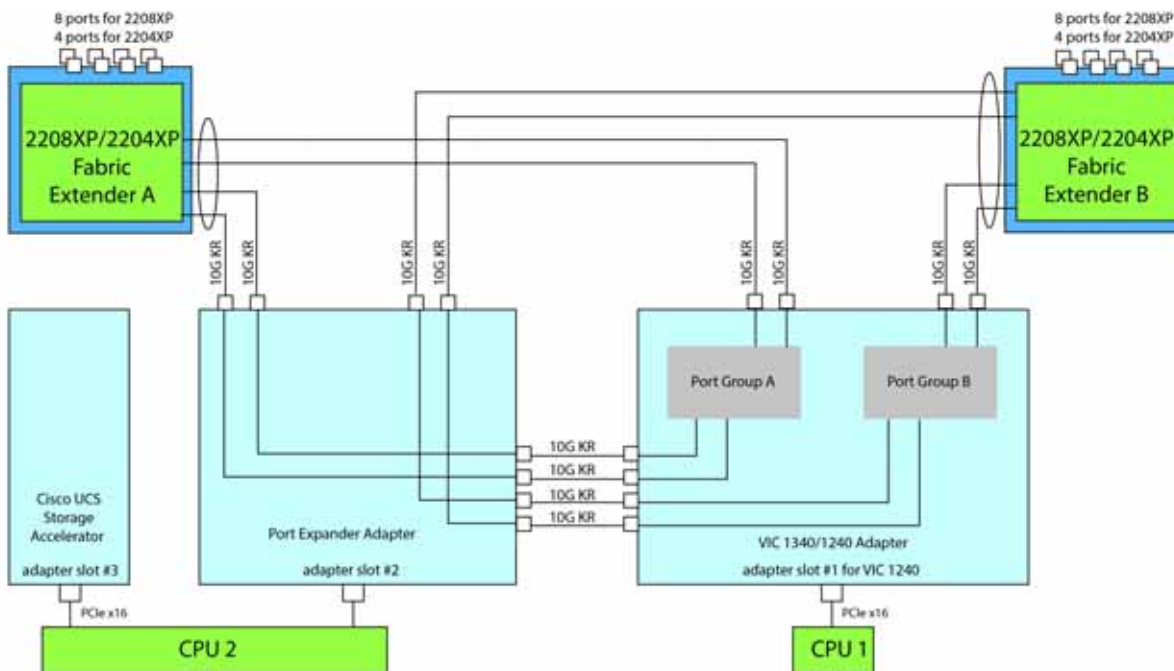

In *Figure 16*, two ports from the VIC 1340/1240 are channeled to Fabric Extender A and two are channeled to Fabric Extender B. The Port Expander Card installed in adapter slot 2 acts as a pass-through device, channeling two ports to each of the Fabric Extenders. Adapter slot 3 is empty. The result is 40 Gb of bandwidth to each Fabric Extender.

Figure 16 VIC 1340/1240 and Port Expander in Adapter Slot 2 (adapter slot 3 empty)

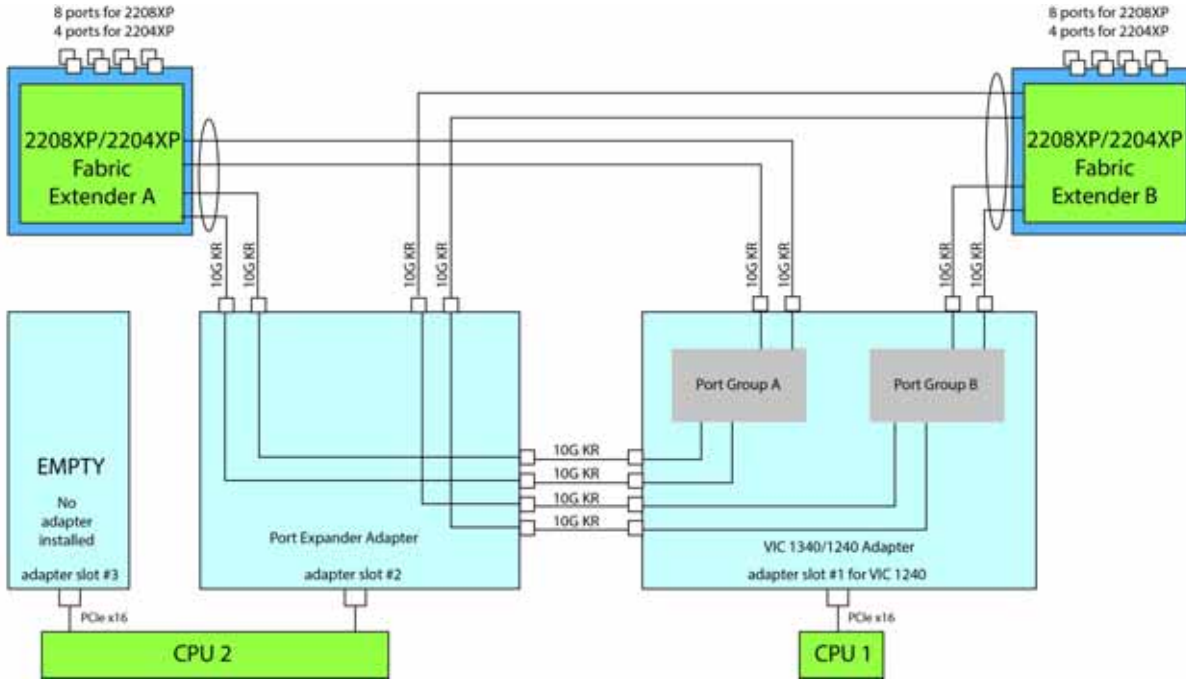

In *Figure 17*, two ports from the VIC 1340/1240 adapter are channeled to Fabric Extender A and two are channeled to Fabric Extender B. UCS storage accelerators are installed in adapter slots 2 and 3, but provide no network connectivity. The result is 20 Gb of bandwidth to each Fabric Extender.

Figure 17 VIC 1340/1240 with UCS storage accelerators installed in adapter slots 2 and 3

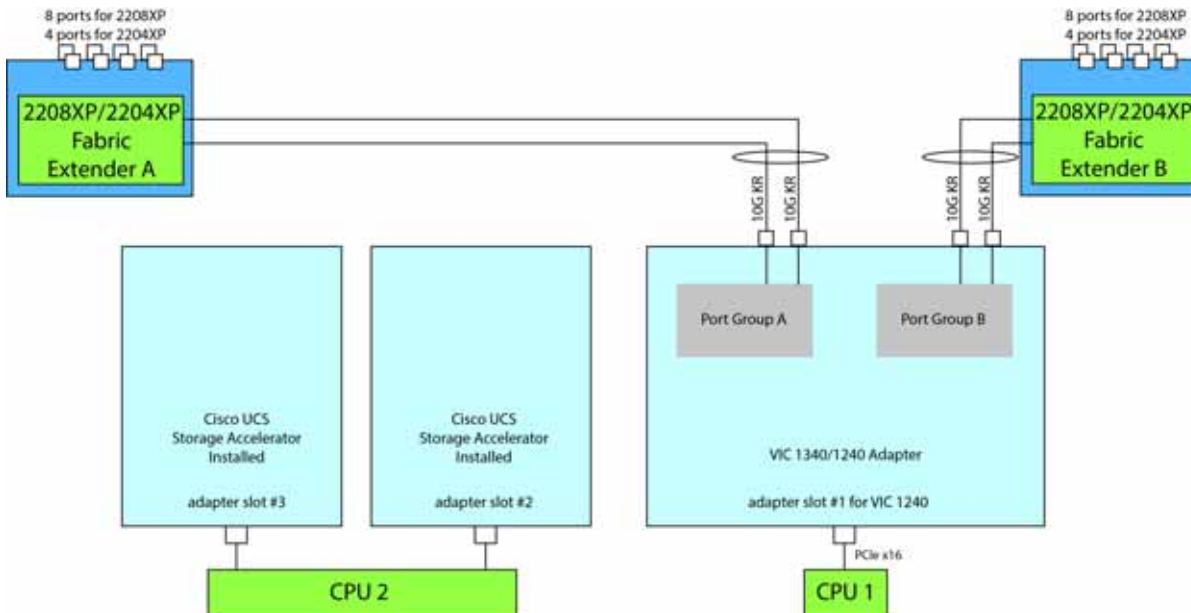

In *Figure 18*, two ports from the VIC 1340/1240 adapter are channeled to Fabric Extender A and two are channeled to Fabric Extender B. A UCS storage accelerator is installed in adapter slot 2 but provides no network connectivity and slot 3 is empty. The result is 20 Gb of bandwidth to each Fabric Extender.

Figure 18 VIC 1340/1240 with UCS storage accelerator installed in adapter slot 2 and slot 3 empty

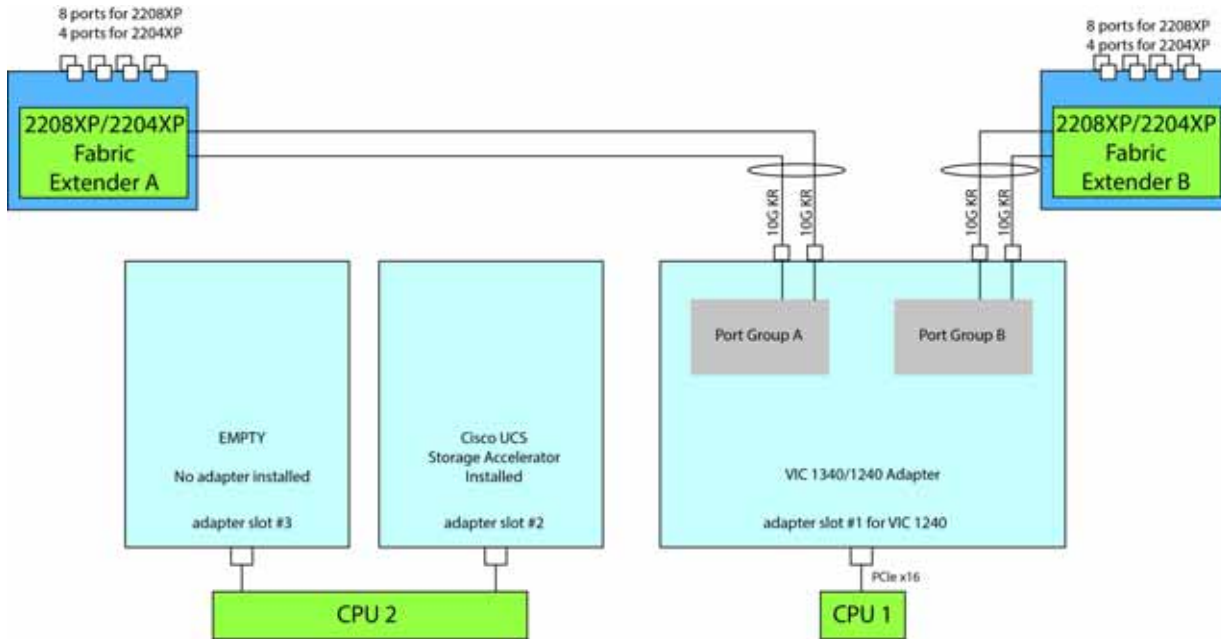

In *Figure 19*, two ports from the VIC 1340/1240 adapter are channeled to Fabric Extender A and two are channeled to Fabric Extender B. Adapter slots 2 and 3 are empty. The result is 20 Gb of bandwidth to each Fabric Extender.

Figure 19 VIC 1340/1240 (adapter slots 2 and 3 empty)

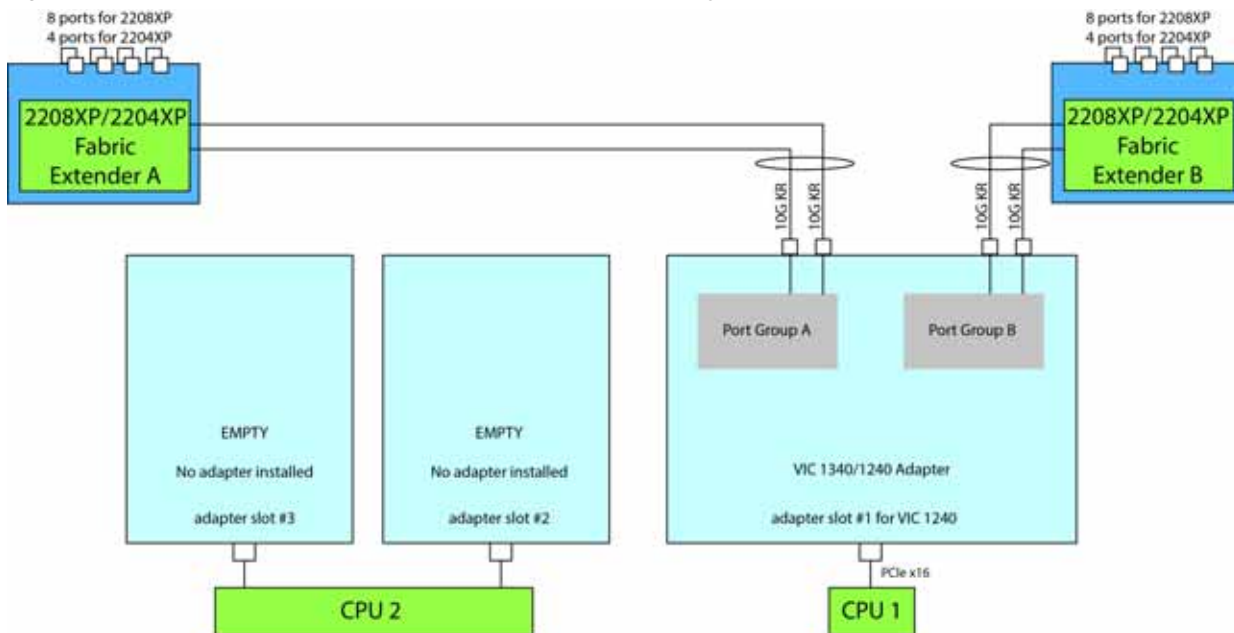

Connectivity using the Cisco UCS 2104XP Fabric Extender

The connectivity options shown in *Figure 20* through *Figure 29* are summarized in *Table 33*.

Table 33 Supported Adapter¹ Combinations Using the 2104XP FEX

Adapter Slot 1	Adapter Slot 2	Adapter Slot 3	Total Available Bandwidth
			2 x 2104XP
VIC 1340/1240	Port Expander Card	VIC 1380/1280	40 Gb <i>Figure 20 on page 59</i>
VIC 1340/1240	Cisco UCS Storage Accelerator	VIC 1380/1280	40 Gb <i>Figure 21 on page 59</i>
VIC 1340/1240	Not populated	VIC 1380/1280	40 Gb <i>Figure 22 on page 60</i>
Not populated	Cisco UCS Storage Accelerator	VIC 1380/1280	20 Gb <i>Figure 23 on page 60</i>
Not populated	Not populated	VIC 1380/1280	20 Gb <i>Figure 24 on page 61</i>
VIC 1340/1240	Port Expander Card	Cisco UCS Storage Accelerator	20 Gb <i>Figure 25 on page 61</i>
VIC 1340/1240	Port Expander Card	Not populated	20 Gb <i>Figure 26 on page 62</i>
Note: for the following configuration, do not mix a Fusion-io adapter with an LSI WarpDrive. Slots 2 and 3 must have identical types of storage cards.			
VIC 1340/1240	Cisco UCS Storage Accelerator	Cisco UCS Storage Accelerator	20 Gb <i>Figure 27 on page 62</i>
VIC 1340/1240	Cisco UCS Storage Accelerator	Not populated	20 Gb <i>Figure 28 on page 63</i>
VIC 1340/1240	Not populated	Not populated	20 Gb <i>Figure 29 on page 63</i>

Notes . . .

1. In the server BIOS and on the motherboard, “Adapter 1,” “Adapter 2,” and “Adapter 3” are labeled as “mLOM,” “Mezz 1,” and “Mezz 2,” respectively

In *Figure 20*, one port from the VIC 1340/1240 is connected to Fabric Extender A and one is connected to Fabric Extender B. The Port Expander Card for the VIC 1340/1240 installed in adapter slot 2 has no role in this case. In addition, the VIC 1380/1280 channels one port to each Fabric Extender. The result is 20 Gb of bandwidth to each Fabric Extender.

Figure 20 VIC 1340/1240, Port Expander in adapter slot 2, and VIC 1380/1280 in adapter slot 3

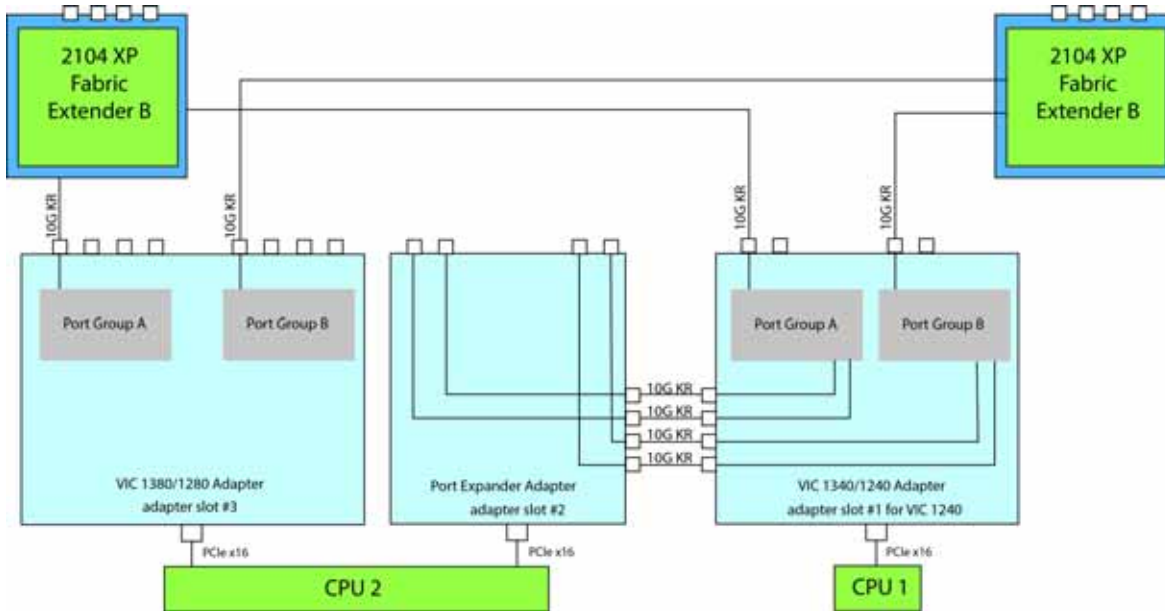

In *Figure 21*, two ports from the VIC 1340/1240 are connected, one to each Fabric Extender. A Cisco UCS Storage Accelerator adapter is installed in slot 2, but provides no network connectivity. The VIC 1380/1280 installed in adapter slot 3 connects two ports, one to each of the Fabric Extenders. The result is 20 Gb of bandwidth to each Fabric Extender.

Figure 21 VIC 1340/1240, Cisco UCS SA adapter slot 2, and VIC 1380/1280 in adapter slot 3

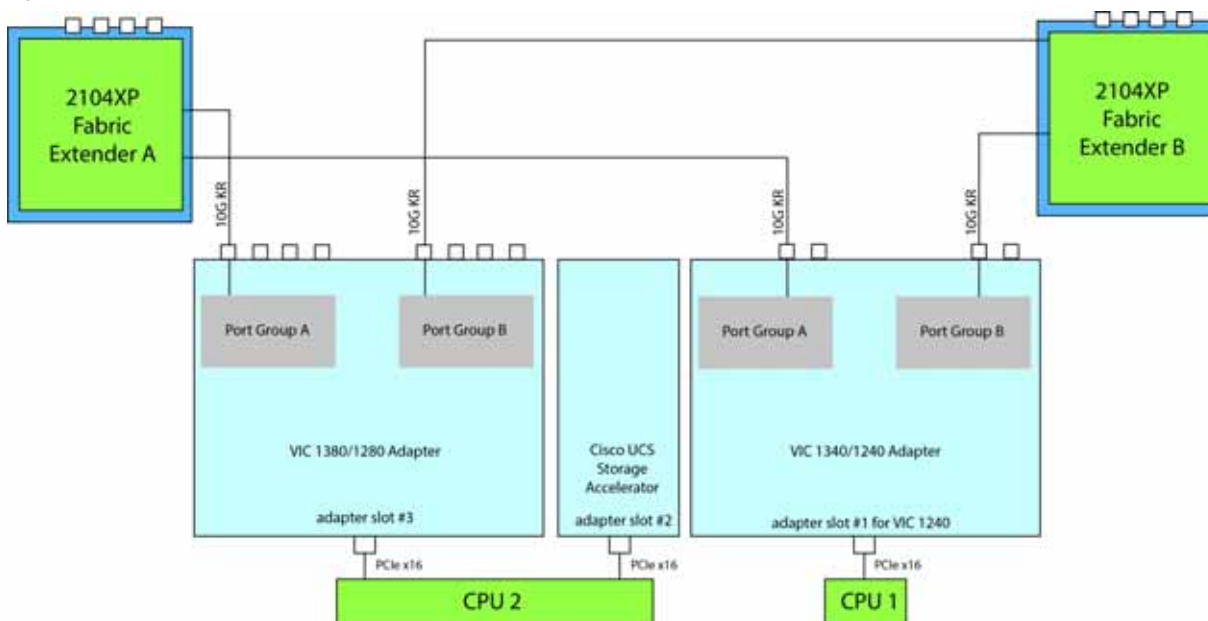

In *Figure 22*, two ports from the VIC 1340/1240 are connected, one to each Fabric Extender. Adapter slot 2 is empty. The VIC 1380/1280 installed in adapter slot 3 connects two ports, one to each of the Fabric Extenders. The result is 20 Gb of bandwidth to each Fabric Extender.

Figure 22 VIC 1340/1240 and VIC 1380/1280 (adapter slot 2 empty)

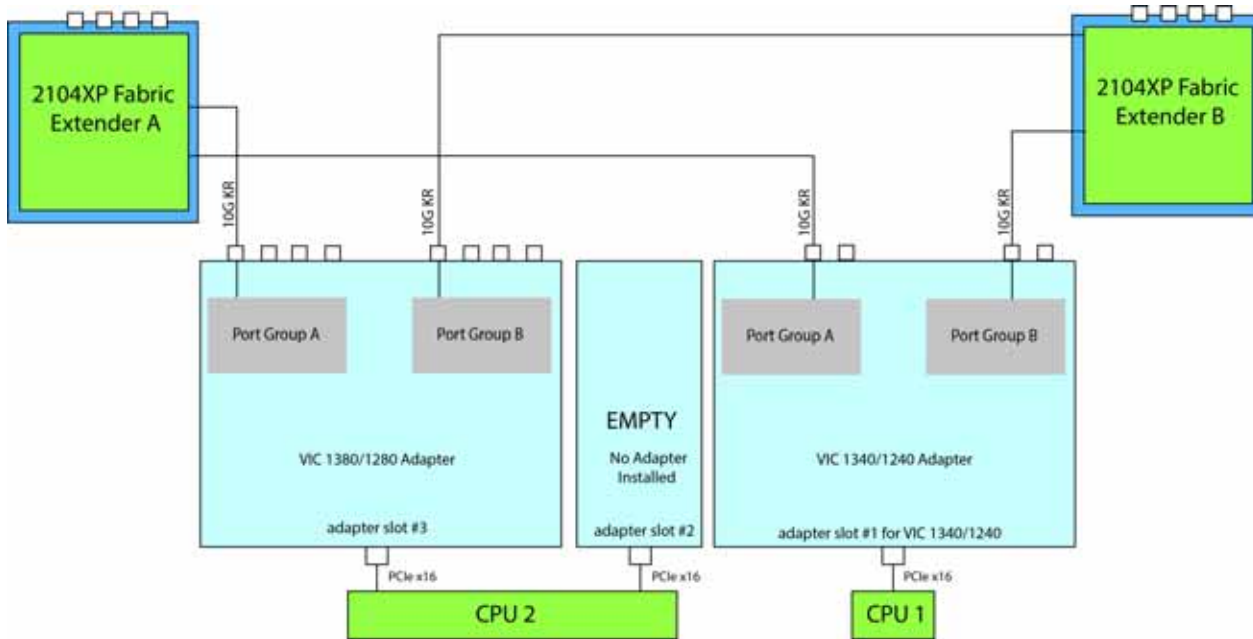

In *Figure 23*, no VIC 1340/1240 is installed. A Cisco UCS Storage Accelerator adapter is installed in slot 2, but provides no network connectivity. The VIC 1380/1280 installed in adapter slot 3 connects two ports, one to each of the Fabric Extenders. The result is 10 Gb of bandwidth to each Fabric Extender.

Figure 23 No VIC 1340/1240 installed, UCS Storage Accelerator in slot 2 and VIC 1380/1280 in slot 3

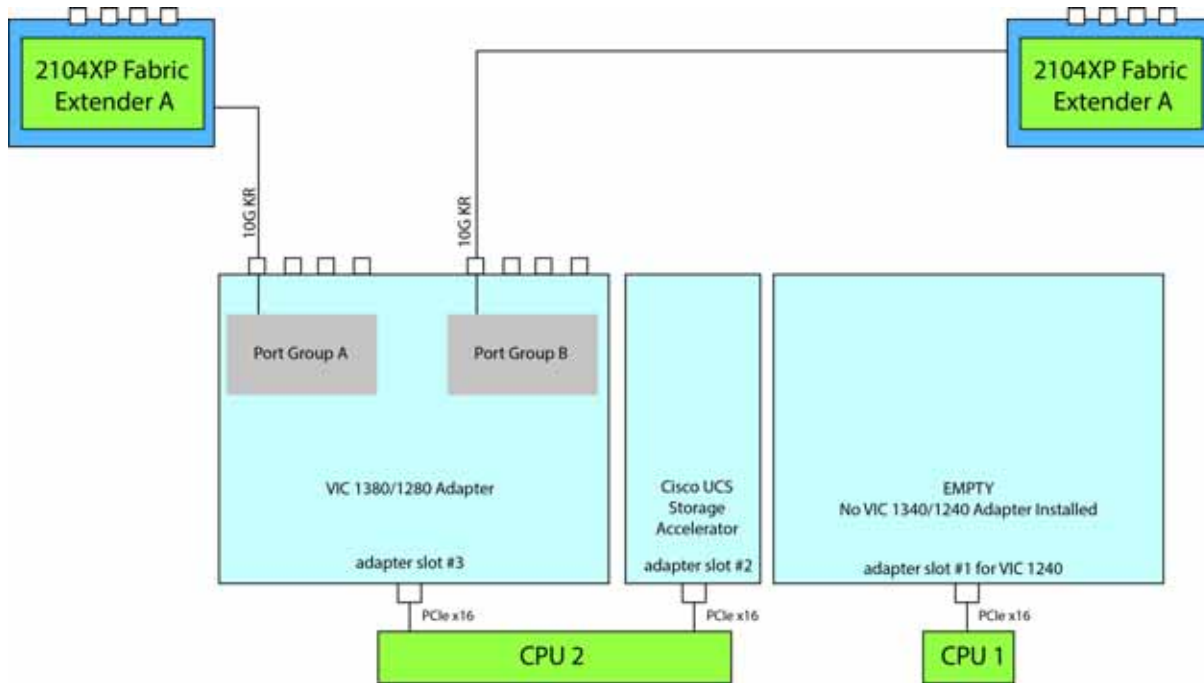

In *Figure 24*, no VIC 1340/1240 is installed. Adapter slot 2 is also not occupied. The VIC 1380/1280 installed in adapter slot 3 connects two ports, one to each Fabric Extender. The result is 10 Gb of bandwidth to each Fabric Extender.

Figure 24 No VIC 1340/1240 installed, no adapter installed in slot 2, and VIC 1380/1280 in slot 3

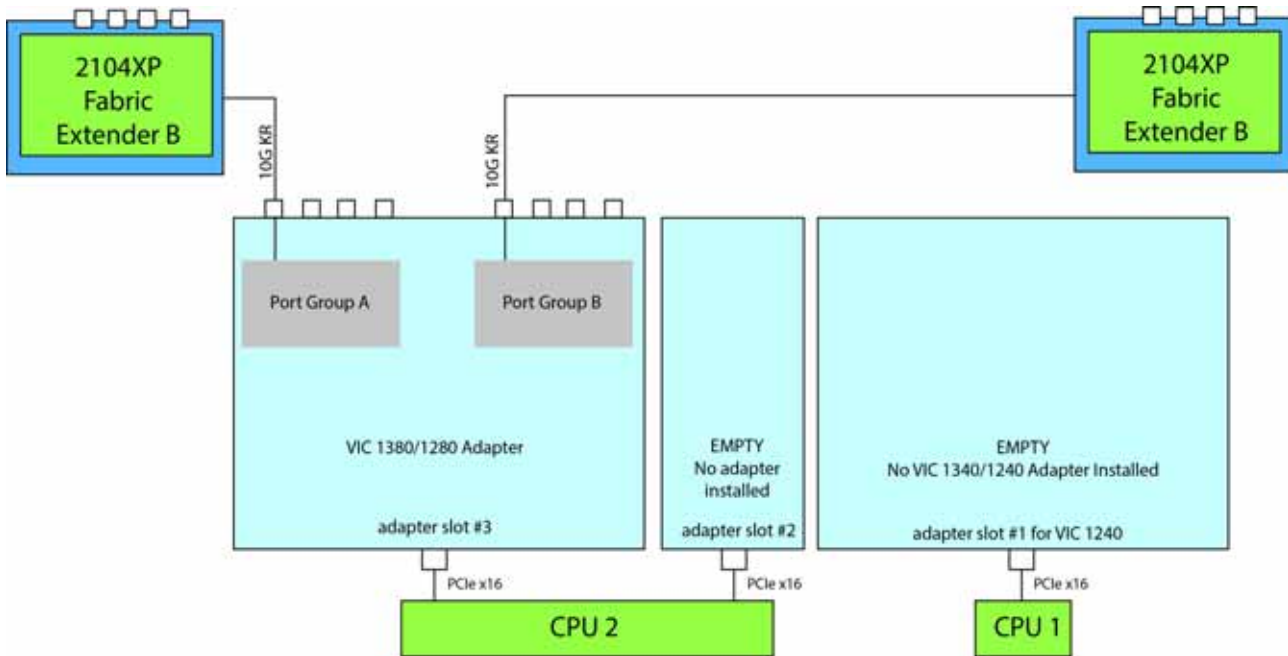

In *Figure 25*, one port from the VIC 1340/1240 is connected to Fabric Extender A and one is connected to Fabric Extender B. The Port Expander Card installed in adapter slot 2 has no role in this case. A Cisco UCS storage accelerator is installed in slot 3, but provides no network connectivity. The result is 10 Gb of bandwidth to each Fabric Extender.

Figure 25 VIC 1340/1240 and Port Expander in Adapter Slot 2 with UCS storage accelerator in slot 3

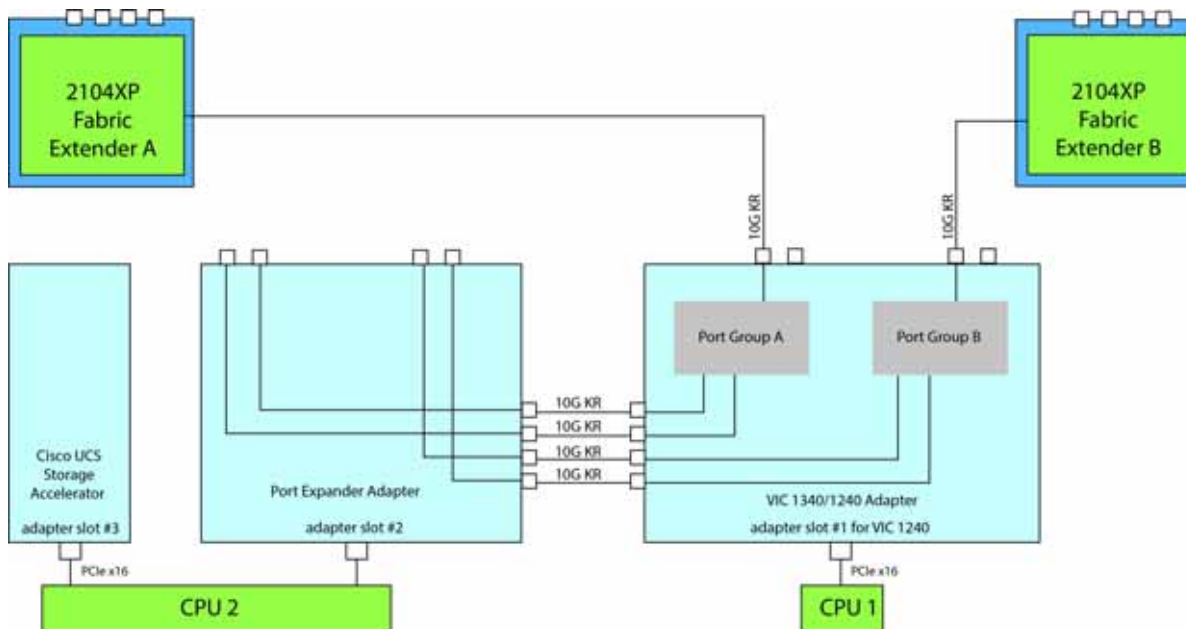

In *Figure 26*, one port from the VIC 1340/1240 is connected to Fabric Extender A and one is connected to Fabric Extender B. The Port Expander Card installed in adapter slot 2 has no role in this case. Adapter slot 3 is empty. The result is 10 Gb of bandwidth to each Fabric Extender.

Figure 26 VIC 1340/1240 and Port Expander in Adapter Slot 2 (adapter 3 empty)

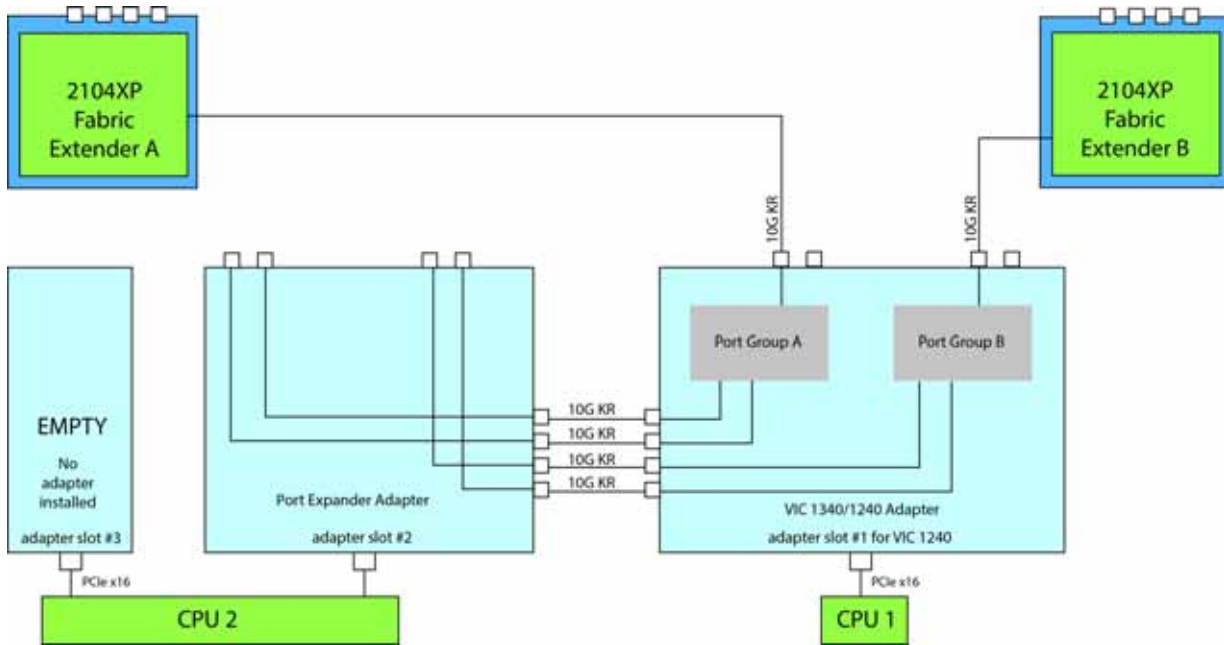

In *Figure 27*, two ports from the VIC 1340/1240 adapter are connected, one to each Fabric Extender. UCS storage accelerators are installed in adapter slots 2 and 3, but provide no network connectivity. The result is 10 Gb of bandwidth to each Fabric Extender.

Figure 27 VIC 1340/1240 with UCS storage accelerators installed in adapter slots 2 and 3

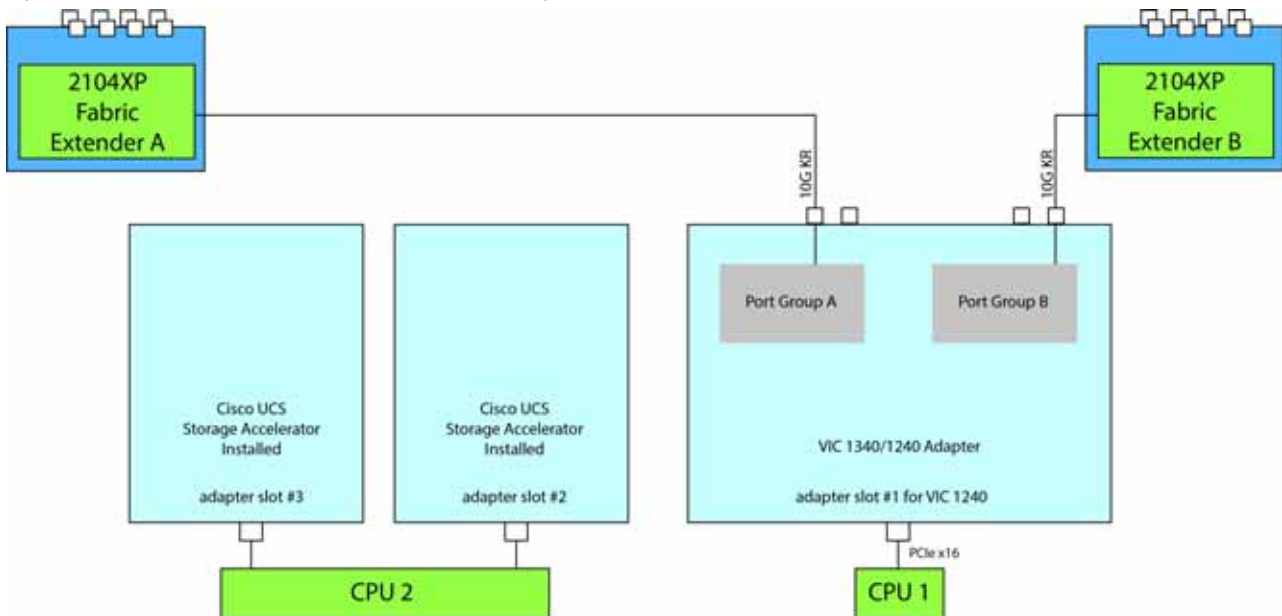

In *Figure 28*, two ports from the VIC 1340/1240 adapter are connected, one to each Fabric Extender. A UCS storage accelerator is installed in adapter slot 2 but provides no network connectivity and slot 3 is empty. The result is 10 Gb of bandwidth to each Fabric Extender.

Figure 28 VIC 1340/1240 with UCS storage accelerator installed in adapter slot 2 and slot 3 empty

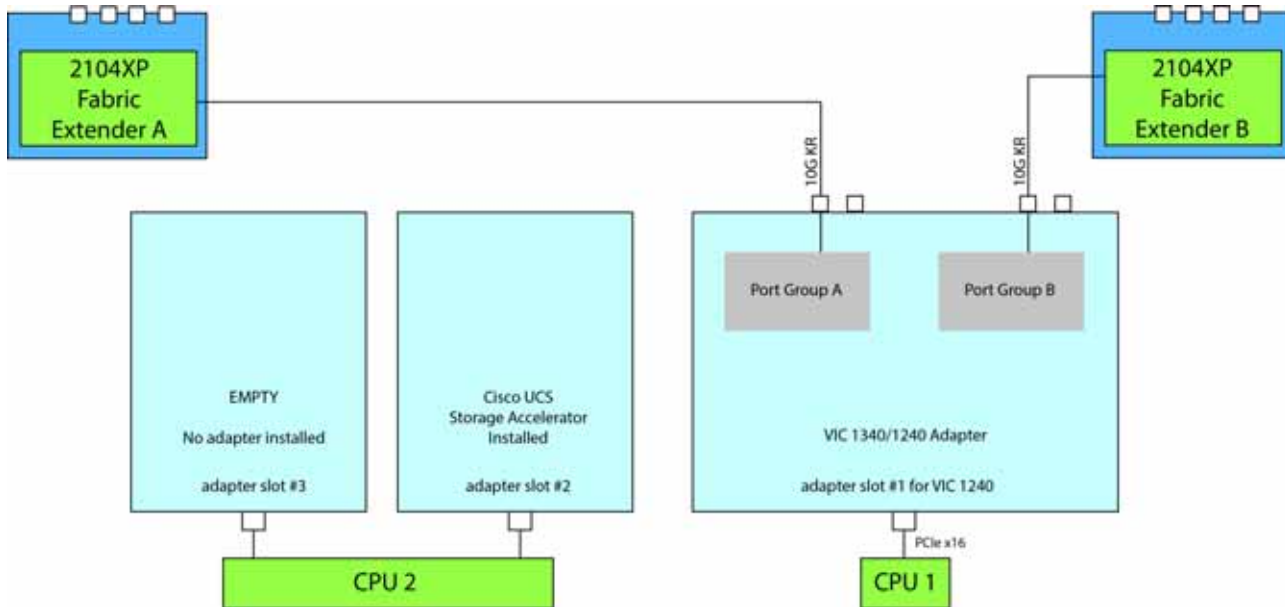

In *Figure 29*, two ports from the VIC 1340/1240 adapter are connected, one to each to Fabric Extender. Adapter slots 2 and 3 are empty. The result is 10 Gb of bandwidth to each Fabric Extender.

Figure 29 VIC 1340/1240 (adapter slots 2 and 3 empty)

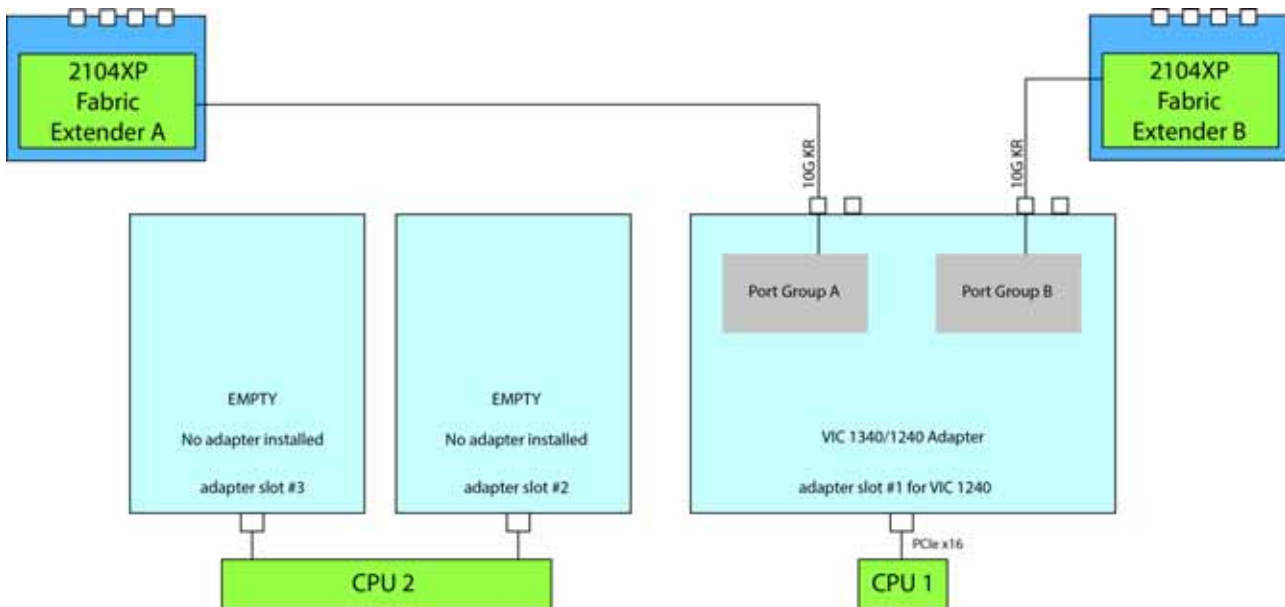

TECHNICAL SPECIFICATIONS

Dimensions and Weight

Table 34 UCS B260 M4 Dimensions and Weight¹

Parameter	Value
Height	1.95 in. (49.53 mm)
Width	17.20 in. (436.9 mm)
Depth	25.5 in. (647.7 mm)
Weight	32.9 lbs (14.9 kg)*

Notes . . .

1. The system weight given here is an estimate for a fully configured system and will vary depending on the number of CPUs, memory DIMMs, and other optional items.

Power Specifications

For configuration-specific power specifications, use the Cisco UCS Power Calculator at:

<http://ucspowercalc.cisco.com>.

Discontinued EOL Products

Below is the list of parts were previously available for this product and are no longer sold. Please refer to the EOL Bulletin Links via the [Table 35](#) below to determine if still supported.

Table 35 EOL Products

EOS option PID	Description	EOL bulletin link
MEMORY		
UCS-MKIT-162RY-E	Mem kit for UCS-MR-2X162RY-E	https://www.cisco.com/c/en/us/products/collateral/servers-unified-computing/ucs-c-series-rack-server/eos-eol-notice-c51-741645.html
UCS-MR-2X162RY-E	2 X 16 GB DDR3-1600 MHz RDIMM/PC3-12800 dual rank/x4/1.35v	https://www.cisco.com/c/en/us/products/collateral/servers-unified-computing/ucs-c-series-rack-server/eos-eol-notice-c51-741645.html
DRIVES		
HDD		
A03-D300GA2	^300GB 6Gb SAS 10K RPM SFF HDD/hot plug/drive sled mounted	http://www.cisco.com/c/en/us/products/collateral/servers-unified-computing/ucs-c-series-rack-servers/eos-eol-notice-c51-737249.html
A03-D600GA2	^600GB 6Gb SAS 10K RPM SFF HDD/hot plug/drive sled mounted	http://www.cisco.com/c/en/us/products/collateral/servers-unified-computing/ucs-c-series-rack-servers/eos-eol-notice-c51-737249.html
UCS-HD12T10KS2-E	1.2 TB 6G SAS 10K rpm SFF HDD	https://www.cisco.com/c/en/us/products/collateral/servers-unified-computing/ucs-c-series-rack-server/eos-eol-notice-c51-735827.html
UCS-HD450G15K12G	450GB 12G SAS 15K RPM SFF HDD	https://www.cisco.com/c/en/us/products/collateral/servers-unified-computing/ucs-c-series-rack-server/eos-eol-notice-c51-740779.html
UCS-HD450G15KS2-E	450GB SAS 15K RPM SFF HDD	http://www.cisco.com/c/en/us/products/collateral/servers-unified-computing/ucs-c-series-rack-servers/eos-eol-notice-c51-736502.html
UCS-HD600G10KS4K	600GB 12G SAS 10K RPM SFF HDD (4K)	https://www.cisco.com/c/en/us/products/collateral/servers-unified-computing/ucs-c-series-rack-server/eos-eol-notice-c51-740779.html
UCS-HD600G15KS2-E	600GB SAS 15K RPM SFF HDD	http://www.cisco.com/c/en/us/products/collateral/servers-unified-computing/ucs-c-series-rack-servers/eos-eol-notice-c51-736502.html

Table 35 EOL Products

EOS option PID	Description	EOL bulletin link
UCS-HD900G10K12G	900GB 12G SAS 10K RPM SFF HDD	https://www.cisco.com/c/en/us/products/collateral/servers-unified-computing/ucs-c-series-rack-server/eos-eol-notice-c51-740779.html
UCS-HDD300GI2F105	300GB 6Gb SAS 15K RPM SFF HDD/hot plug/drive sled mounted	http://www.cisco.com/c/en/us/products/collateral/servers-unified-computing/ucs-c-series-rack-servers/eos-eol-notice-c51-736502.html
UCS-HDD900GI2F106	^900GB 6Gb SAS 10K RPM SFF HDD/hot plug/drive sled mounted	http://www.cisco.com/c/en/us/products/collateral/servers-unified-computing/ucs-c-series-rack-servers/eos-eol-notice-c51-737249.html
Enterprise Performance		
UCS-SD200G0KS2-EP	200GB 2.5 inch Enterprise Performance SAS SSD	https://www.cisco.com/c/en/us/products/collateral/servers-unified-computing/ucs-c-series-rack-server/eos-eol-notice-c51-735827.html
UCS-SD400G0KS2-EP	400GB 2.5 inch Enterprise Performance SAS SSD	https://www.cisco.com/c/en/us/products/collateral/servers-unified-computing/ucs-c-series-rack-server/eos-eol-notice-c51-735827.html
UCS-SD800G0KS2-EP	800GB 2.5 inch Enterprise Performance SAS SSD	https://www.cisco.com/c/en/us/products/collateral/servers-unified-computing/ucs-c-series-rack-server/eos-eol-notice-c51-735827.html
Enterprise Value		
UCS-SD100G0KA2-G	^100GB 2.5 inch Enterprise Value SSD	http://www.cisco.com/c/en/us/products/collateral/servers-unified-computing/ucs-c-series-rack-servers/eos-eol-notice-c51-732949.html
UCS-SD120G0KS2-EV	120 GB 2.5 inch Enterprise Value 6G SATA SSD	http://www.cisco.com/c/en/us/products/collateral/servers-unified-computing/ucs-c-series-rack-servers/eos-eol-notice-c51-736502.html
UCS-SD120GBKS4-EV	120 GB 2.5 inch Enterprise Value 6G SATA SSD	https://www.cisco.com/c/en/us/products/collateral/servers-unified-computing/ucs-c-series-rack-server/eos-eol-notice-c51-740779.html
UCS-SD16TBKS4-EV	1.6TB 2.5 inch Enterprise Value 6G SATA SSD	https://www.cisco.com/c/en/us/products/collateral/servers-unified-computing/ucs-c-series-rack-server/eos-eol-notice-c51-740779.html
UCS-SD400G0KA2-G	^400GB 2.5 Enterprise Value SSD	http://www.cisco.com/c/en/us/products/collateral/servers-unified-computing/ucs-c-series-rack-servers/eos-eol-notice-c51-732949.html

Table 35 EOL Products

EOS option PID	Description	EOL bulletin link
UCS-SD480G0KS2-EV	480 GB 2.5 inch Enterprise Value 6G SATA SSD	http://www.cisco.com/c/en/us/products/collateral/servers-unified-computing/ucs-c-series-rack-servers/eos-eol-notice-c51-736502.html
UCS-SD480GBKS4-EV	480 GB 2.5 inch Enterprise Value 6G SATA SSD	https://www.cisco.com/c/en/us/products/collateral/servers-unified-computing/ucs-c-series-rack-servers/eos-eol-notice-c51-740779.html



Americas Headquarters
Cisco Systems, Inc.
San Jose, CA

Asia Pacific Headquarters
Cisco Systems (USA) Pte. Ltd.
Singapore

Europe Headquarters
Cisco Systems International BV Amsterdam,
The Netherlands

Cisco has more than 200 offices worldwide. Addresses, phone numbers, and fax numbers are listed on the Cisco Website at www.cisco.com/go/offices.

Cisco and the Cisco Logo are trademarks of Cisco Systems, Inc. and/or its affiliates in the U.S. and other countries. A listing of Cisco's trademarks can be found at www.cisco.com/go/trademarks. Third party trademarks mentioned are the property of their respective owners. The use of the word partner does not imply a partnership relationship between Cisco and any other company. (1005R)