



# Cisco 7200 VXR Product Overview

This chapter provides physical and functional overviews of the Cisco 7200 VXR routers. Descriptions and examples of software commands are included when they are necessary for replacing, installing, configuring, or maintaining the router hardware.

The following sections describe router hardware, major components, and functions of hardware-related features:

- [Physical Description, page 1-1](#)
- [Cisco 7204VXR Overview, page 1-4](#)
- [Cisco 7206VXR Overview, page 1-7](#)
- [Field-Replaceable Units, page 1-10](#)
- [Functional Overview, page 1-50](#)



Warning

Before you install, operate, or service the system, read the *Site Preparation and Safety Guide*. This guide contains important safety information you should know before working with the system.

## Physical Description

The Cisco 7200 VXR routers are the newest, multiservice members of the Cisco 7200 series routers. The Cisco 7200 VXR routers include the Cisco 7204VXR (4-slot router) and the Cisco 7206VXR (6-slot router). The Cisco 7200 VXR routers are designed to support gigabit capabilities and to improve data, voice, and video integration in both service provider and enterprise environments.

The Cisco 7200 VXR routers incorporate an integrated Multiservice Interchange (MIX) capability to support future voice applications. MIX interconnections on the midplane provide the ability to switch DS-0 time slots between multichannel T1 or E1 interfaces, much like a digital cross-connect or an add-drop multiplexer. This feature enables the Cisco 7200 VXR routers to switch DS-0 voice channels on a T1 or E1 interface from one voice processing port adapter to another voice processing port adapter. It also enables DS-0s to be switched through the Cisco 7200 VXR routers without any processing, a requirement in certain voice configurations.

The Cisco 7200 VXR routers support the high-speed network processing engine, NPE-G1, as well as the network services engine (NSE-1) and all other available network processing engines. The NPE-G1 provides high speed performance with the BCM 1250 700-Mhz processor and supports three Gigabit Ethernet interfaces with no additional bandwidth requirements. The NSE-1 is a combination of a

high-performance RISC processor and a high-performance PXF processor. The PXF processor works with the Route Processor to provide accelerated packet switching, as well as accelerated IP Layer 3 feature processing.

The Cisco 7200 VXR routers also support high-speed network processing engines (NPEs) to provide increased routing and process switching performance.

The Cisco 7200 VXR routers with the NPE-G1, NPE-400, and NSE-1 installed support both 25-MHz and 50-MHz port adapter operation.

**Note**

For port adapter configuration information, refer to the *Cisco 7200 Series Port Adapter Configuration Guidelines* publication.

The Cisco 7200 VXR routers accommodate a variety of network interface port adapters and I/O controllers. A Cisco 7200 VXR router equipped with an NPE-G1, NSE-1, or NPE-400 can support up to six high-speed port adapters and can also support higher-speed port adapter interfaces including Gigabit Ethernet and OC-12 ATM. The Cisco 7200 VXR routers also contain bays for up to two AC-input or DC-input power supplies.

The port adapters, I/O controller, and power supplies are the same for all Cisco 7200 series routers and are described in the [“Field-Replaceable Units” section on page 1-10](#). The network processing engines and network services engine are router model specific.

The Cisco 7200 VXR routers support the following features:

- Online insertion and removal (OIR)—Allows you to add, replace, or remove port adapters without interrupting the system.
- Dual hot-swappable, load-sharing power supplies—Provide system power redundancy; if one power supply or power source fails, the other power supply maintains system power without interruption. Also, when one power supply is powered off and removed from the router, the second power supply immediately takes over the router’s power requirements without interrupting normal operation of the router.
- Environmental monitoring and reporting functions—Allow you to maintain normal system operation by resolving adverse environmental conditions prior to loss of operation.
- Downloadable software—Allows you to load new images into Flash memory remotely, without having to physically access the router, for fast, reliable upgrades.

[Table 1-1](#) lists the Cisco 7200 VXR physical specifications and power requirements.

**Table 1-1 Cisco 7200 VXR Physical Specifications**

Description	Specification
Midplane	<p>Two primary PCI buses, and one secondary PCI bus</p> <ul style="list-style-type: none"> <li>• With an NPE-G1 and an I/O controller installed, the I/O controller does not use bandwidth points, and the NPE-G1 does use bandwidth points. The NPE-G1 does not use bandwidth points if installed without the I/O controller.</li> <li>• With NSE-1, NPE-400, or NPE-300 installed: aggregate bandwidth of 900 Mbps<sup>1</sup></li> <li>• With NPE-100, NPE-150, or NPE-200 installed: aggregate bandwidth of 600 Mbps</li> </ul>

Table 1-1 Cisco 7200 VXR Physical Specifications (continued)

Description	Specification
Dimensions (H x W x D)	5.25 in. x 16.8 in. x 17 in. (13.34 cm x 42.67 cm x 43.18 cm)
Weight	Chassis fully configured with a network processing engine or network services engine, I/O controller, maximum number of port adapters, 2 power supplies, and a fan tray: ~ 50 lb (22.7 kg)
Heat dissipation	370W (1262 BTU <sup>2</sup> )
AC-input voltage rating	100–240 VAC <sup>3</sup> wide input with power factor correction
AC-input current rating	5A <sup>4</sup> at 100–240 VAC with the chassis fully configured
AC-input frequency rating	50/60 Hz <sup>5</sup>
AC-input cable	18 AWG <sup>6</sup> three-wire cable, with a three-lead IEC-320 receptacle on the power supply end, and a country-dependent plug on the power source end
DC-output power	280W maximum (with either a single or dual power supply configuration)
DC-input voltage rating	–48 VDC <sup>7</sup> nominal in North America –60 VDC nominal in the European Community
DC-input current rating	13A at –48 VDC (370W/–48 VDC = 7.7A typical draw) 8A at –60 VDC (370W/–60 VDC = 6.2A typical draw)
DC-input cable	In accordance with local and national wiring regulations
Chassis fan noise levels—single speed fan	Tested: <ul style="list-style-type: none"> <li>• Front (I/O controller and port adapter side) 44.2 dB</li> <li>• Back (power supply side) 43.7 dB</li> <li>• Left (fan side) 47.2 dB</li> <li>• Right 44.8 dB</li> </ul> Maximum: 65 dBa
Airflow	~80 cfm <sup>8</sup>
Temperature	32 to 104 F (0 to 40 C) operating; –4 to 149 F (–20 to 65 C) nonoperating
Humidity	10 to 90% noncondensing
Recommended minimum software requirements	Cisco IOS Release 12.0(2)XE2 or later releases of 12.0 XE Cisco IOS Release 12.1(1)E or later releases of 12.1 E Cisco IOS Release 12.0(5)S or later releases of 12.0 S Cisco IOS Release 12.0(3)T or later releases of 12.0 T Cisco IOS Release 12.2(1) or later releases of 12.2 Cisco IOS Release 12.2 (4)B or later releases of 12.2 B(
Compliance	CE Marking

Table 1-1 Cisco 7200 VXR Physical Specifications (continued)

Description	Specification
Safety	UL 1950, CSA 22.2 No. 950, EN60950, AUSTEL TS001, AS/NZS 3260, IEC 60950, IEC 60825, EN 60825, 21CFR1040
EMI	FCC Class A (47 CFR, Part 15), ICES-003 Class A, EN55022 Class B, CISPR22 Class B, AS/NZS 3548 Class B, and VCCI Class B

1. Mbps = megabits per second
2. BTU = British thermal units
3. VAC = volts alternating current
4. A = amperes
5. Hz = hertz
6. AWG = American Wire Gauge
7. VDC = volts direct current
8. cfm = cubic feet per minute

**Note**

For a chassis footprint, additional dimensions, and clearance requirements for the Cisco 7200 VXR routers, see the [“Site Requirement Guidelines”](#) section on page 2-3 in Chapter 2, “Preparing for Installation.”

## Cisco 7204VXR Overview

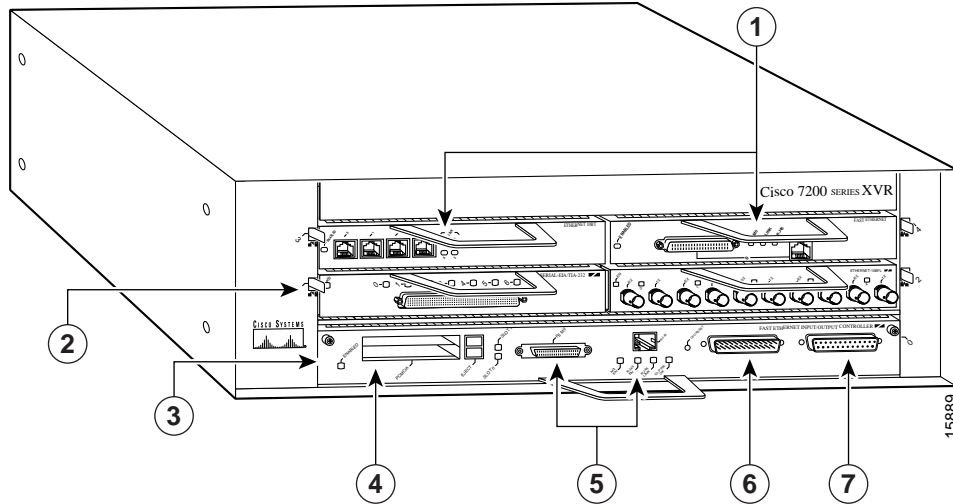
The Cisco 7204VXR supports multiprotocol, multimedia routing and bridging with a wide variety of protocols and port adapter combinations available for Cisco 7200 series routers. In addition, the Cisco 7204VXR midplane provides increased support for multiple high-bandwidth port adapters.

The Cisco 7204VXR has four slots (slot 1 through slot 4) for port adapters, one slot for an input/output (I/O) controller, and one slot for a network processing engine or network services engine. You can place the port adapters in any of the four available slots. (See [Figure 1-1](#).)

**Note**

If you have difficulty installing a processing engine or I/O controller in the lowest slot of a Cisco 7200 VXR router that is rack-mounted, remove the port adapters, processing engine and I/O controller from the chassis and reinstall them. Install the processing engine and I/O controller in the lowest slots first, then populate the slots above them, in a bottom-to-top order.

Figure 1-1 Cisco 7204VXR Router—Front View



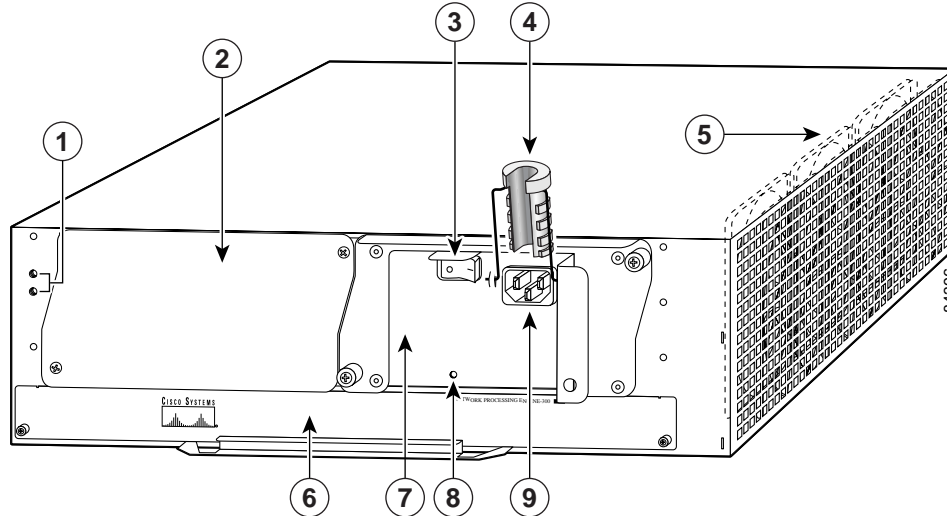
1	Port adapters	5	Optional Fast Ethernet interface (MII port and RJ-45 port)
2	Port adapter lever	6	Auxiliary port
3	I/O controller	7	Console port
4	PC Card slots		

**Note**

In [Figure 1-1](#), a blank port adapter is installed in slot 3. To ensure adequate airflow across the port adapters, each port adapter slot must be filled with either a port adapter or a blank port adapter.

The rear of the Cisco 7204VXR router provides access to the network processing engine or network services engine and up to two power supplies. (See [Figure 1-2](#).)

Figure 1-2 Cisco 7204VXR Router—Rear View



1	Chassis grounding receptacles	6	Network processing engine or network services engine
2	Power supply filler plate	7	AC-input power supply
3	Power switch	8	PWR OK LED
4	AC power cable-retention clip	9	AC power supply receptacle
5	Internal fans		

The network processing engines NPE-100 through NPE-400 or network services engine (NSE-1) have no external connectors or LEDs. There is a handle for removing and installing the network processing engine or network services engine and two captive installation screws for securing it to the chassis.

The NPE-G1 has external connectors and LEDs for the Gigabit Ethernet interfaces as well as console and auxiliary ports.

The Cisco 7204VXR router comes equipped with one 280W AC-input power supply. (A 280W DC-input power supply option is available.) In Figure 1-2, a Cisco 7204VXR router is configured with a single AC-input power supply. (A power supply filler plate is installed over the second power supply bay.) A fully configured Cisco 7204VXR router operates with only one installed power supply; however, a second, optional power supply of the same type provides hot-swappable, load-sharing, redundant power.

**Note**

The Cisco 7204VXR does not support a mixture of AC- and DC-input power.

The power supply has the router's main power switch and either an AC-input power receptacle or a hardwired DC-input power cable (depending on the type of installed power supply).

**Caution**

Do not mix power supplies in the Cisco 7204VXR. In dual power supply router configurations, both power supplies *must* be of the same type (two AC-input power supplies or two DC-input power supplies).

Adjacent to the power supply bays are two chassis grounding receptacles that provide a chassis ground connection for ESD equipment or a two-hole grounding lug. (See Figure 1-2.)

Three internal fans draw cooling air into the chassis and across internal components to maintain an acceptable operating temperature. (See [Figure 1-2](#).) The three fans are enclosed in a tray that is located inside the chassis.

**Caution**

To ensure the proper flow of cooling air across the internal components, make sure blank port adapters are installed in unoccupied port adapter slots, and power supply filler plates are installed in unoccupied power supply bays.

The I/O controller, port adapters, power supplies, and network processing engine or network services engine slide into their respective chassis slots and connect directly to the routers midplane; there are no internal cables to connect. The midplane distributes power from the power supplies to the I/O controller, port adapters, fan tray, and network processing engine or network services engine.

The midplane also senses OIR of the port adapters, bridges the PCI buses from the port adapters to packet memory on the network processing engine or network services engine, arbitrates traffic across the PCI buses, and generates the clock signals for the port adapters on each PCI bus.

The Cisco 7204VXR operates as either a tabletop or a rack-mounted unit. A rack-mount kit is standard equipment included with all Cisco 7200 VXR routers when they are shipped from the factory. The kit provides the hardware needed to mount the router in a standard 19-inch equipment rack or a 2-post rack. Steps for installing the Cisco 7204VXR router in an equipment rack are the same for all Cisco 7200 VXR routers and are explained in Chapter 3, “[Installing a Cisco 7200 VXR Router](#).” If you are not rack-mounting your Cisco 7204VXR, place it on a sturdy tabletop or platform.

A fully configured Cisco 7204VXR, with two installed power supplies and all chassis slots filled, weighs approximately 50 pounds (22.7 kilograms [kg]). For clearance requirements and rack-mount installation considerations, see [Chapter 2, “Preparing for Installation,”](#) the “[Site Requirement Guidelines](#)” section on page 2-3.

## Cisco 7206VXR Overview

The Cisco 7206VXR supports multiprotocol, multimedia routing and bridging with a wide variety of protocols and port adapter combinations available for Cisco 7200 series routers. In addition, the Cisco 7206VXR midplane provides increased support for multiple high-bandwidth port adapters.

**Note**

The Cisco 7206VXR is also available as a router shelf in a Cisco AS5800 Universal Access Server. If your Cisco 7206VXR is installed as a router shelf, use this publication in conjunction with the Cisco AS5800 Universal Access Server publications that shipped with the access server.

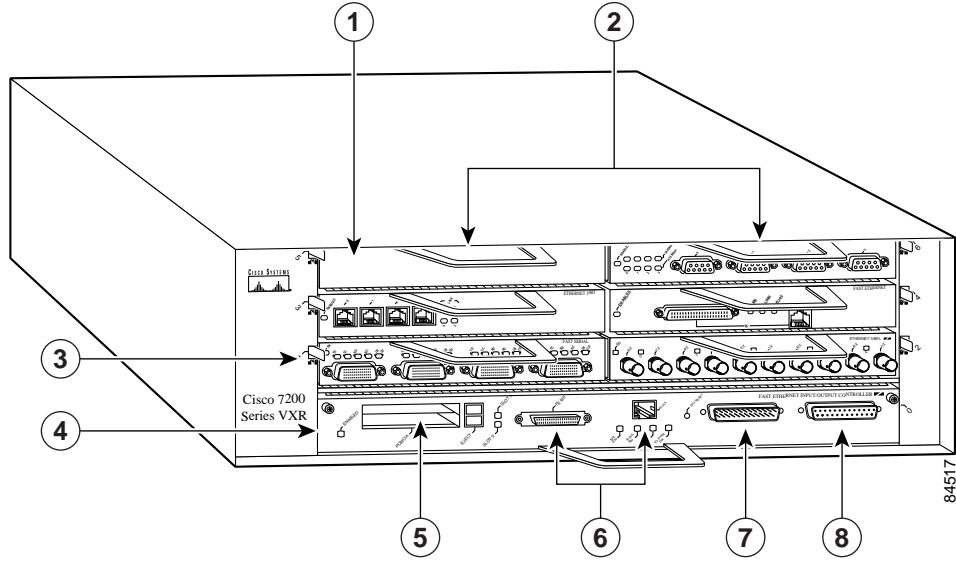
The Cisco 7206VXR has six slots (slot 1 through slot 6) for port adapters, one slot for an input/output (I/O) controller, and one slot for a network processing engine or network services engine. You can place the port adapters in any of the six available slots.

The front of the Cisco 7206VXR provides access to the I/O controller and up to six network interface port adapters. (See [Figure 1-3](#).)

**Note**

If you have difficulty installing a processing engine or I/O controller in the lowest slot of a Cisco 7200 VXR router that is rack-mounted, remove the port adapters, processing engine and I/O controller from the chassis and reinstall them. Install the processing engine and I/O controller in the lowest slots first, then populate the slots above them, in a bottom-to-top order.

Figure 1-3 Cisco 7206VXR Router—Front View



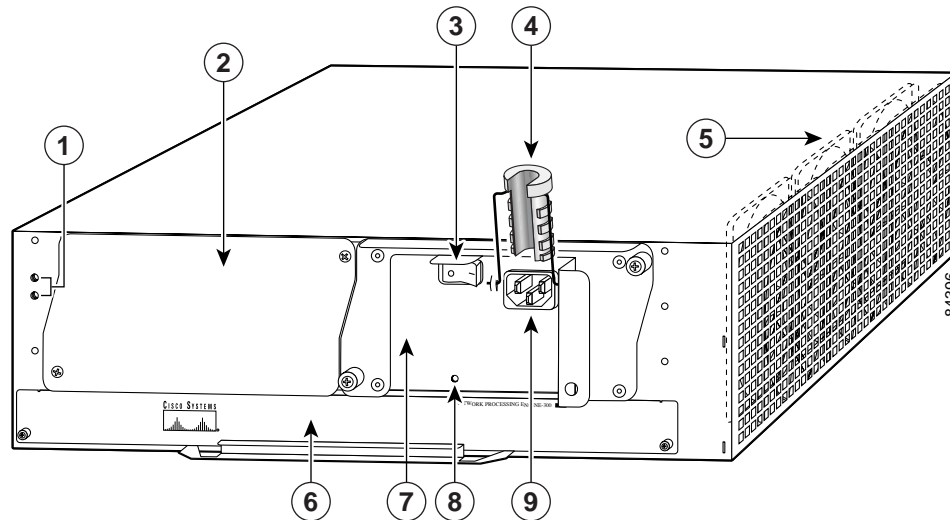
1	Blank port adapter	5	PC Card slots
2	Port adapters	6	Optional Fast Ethernet interface (MII port and RJ-45 port)
3	Port adapter lever	7	Auxiliary port
4	I/O controller	8	Console port

**Note**

In [Figure 1-3](#), a blank port adapter is installed in slot 5. To ensure adequate airflow across the port adapters, each port adapter slot must be filled with either a port adapter or a blank port adapter.



Figure 1-4 Cisco 7206VXR Router—Rear View



1	Chassis grounding receptacles	6	Network processing engine or network services engine
2	Power supply filler plate	7	AC-input power supply
3	Power switch	8	PWR OK LED
4	AC power cable-retention clip	9	AC power supply receptacle
5	Internal fans		

The rear of the Cisco 7206VXR router provides access to the network processing engine or network services engine and up to two power supplies. (See [Figure 1-4](#).)

The NPE-G1 can be used without an I/O controller, and has three Gigabit Ethernet interfaces, a CompactFlash Disk slot, and auxiliary and console port connections as well as status LEDs.

The network processing engines NPE-100 through NPE-400 or network services engine (NSE-1) have no external connectors or LEDs. There is a handle for removing and installing the network processing engine or network services engine and two captive installation screws for securing it to the chassis.

The NPE-G1 has external connectors and LEDs for the Gigabit Ethernet interfaces as well as console and auxiliary ports.

The Cisco 7206VXR router comes equipped with one 280W AC-input power supply. (A 280W DC-input power supply option is available.) In [Figure 1-4](#), a Cisco 7206VXR router is configured with a single AC-input power supply. (A power supply filler plate is installed over the second power supply bay.) A fully configured Cisco 7206VXR router operates with only one installed power supply; however, a second, optional power supply of the same type provides hot-swappable, load-sharing, redundant power.



#### Note

The Cisco 7206VXR does not support a mixture of AC- and DC-input power.

The power supply has the router's main power switch and either an AC-input power receptacle or a hardwired DC-input power cable (depending on the type of installed power supply).

**Caution**

Do not mix power supplies in the Cisco 7206VXR. In dual power supply router configurations, both power supplies *must* be of the same type (two AC-input power supplies or two DC-input power supplies).

Adjacent to the power supply bays are two chassis grounding receptacles that provide a chassis ground connection for ESD equipment or a two-hole grounding lug. (See [Figure 1-4](#).)

Three internal fans draw cooling air into the chassis and across the internal components to maintain an acceptable operating temperature. (See [Figure 1-4](#).) The three fans are enclosed in a tray that is located inside the chassis.

**Caution**

To ensure the proper flow of cooling air across the internal components, make sure blank port adapters are installed in unoccupied port adapter slots, and power supply filler plates are installed in unoccupied power supply bays.

The I/O controller, port adapters, power supplies, and network processing engine or network services engine slide into their respective chassis slots and connect directly to the router's midplane; there are no internal cables to connect. The midplane distributes power from the power supplies to the I/O controller, port adapters, fan tray, and network processing engine or network services engine.

The midplane also senses OIR of the port adapters, bridges the PCI buses from the port adapters to packet memory on the network processing engine or network services engine, arbitrates traffic across the PCI buses, and generates the clock signals for the port adapters on each PCI bus.

The Cisco 7206VXR operates as either a tabletop or a rack-mounted unit. A rack-mount kit is standard equipment included with all Cisco 7200 VXR routers when they are shipped from the factory. The kit provides the hardware needed to mount the router in a standard 19-inch equipment rack or a 2-post rack. Steps for installing the Cisco 7206VXR router in an equipment rack are the same for all Cisco 7200 VXR routers and are explained in Chapter 3, "[Installing a Cisco 7200 VXR Router](#)." If you are not rack-mounting your Cisco 7206VXR, place it on a sturdy tabletop or platform.

A fully configured Cisco 7206VXR, with two installed power supplies and all chassis slots filled, weighs approximately 50 pounds (22.7 kilograms [kg]). For clearance requirements and rack-mount installation considerations, see [Chapter 2, "Preparing for Installation,"](#) the "[Site Requirement Guidelines](#)" section on page 2-3.

## Field-Replaceable Units

The Cisco 7200 VXR routers are easy to service; many of their major components are field-replaceable units (FRUs). The following sections describe Cisco 7200 VXR router FRUs:

- [Network Processing Engine or Network Services Engine, page 1-11](#)
- [Input/Output Controller, page 1-30](#)
- [LED Descriptions, page 1-38](#)
- [Port Adapters and Service Adapters, page 1-44](#)
- [Power Supplies, page 1-45](#)
- [Chassis, page 1-47](#)
- [CompactFlash Disks, Flash Disks and PC Cards, page 1-48](#)
- [Rack-Mount and Cable-Management Kit, page 1-49](#)

**Note**

Replacement instructions for removing and replacing FRUs are contained in separate documents that accompany each FRU shipped from the factory. For example, if you need to replace an AC power supply in your Cisco 7200 VXR router, refer to the *280-Watt AC-Input Power Supply Replacement Instructions* publication. Replacement instructions are also available on the Documentation CD-ROM and on Cisco.com.

## Network Processing Engine or Network Services Engine

The network processing engine or network services engine maintains and executes the system management functions for Cisco 7200 VXR routers. Also, the network processing engine or network services engine shares the system memory and environmental monitoring functions with the I/O controller.

Because the NPE-G1 contains I/O functionality the Cisco 7200 VXR routers can operate with no I/O controller with an NPE-G1 installed. With both an I/O controller and the NPE-G1 installed, the NPE-G1 enhances the I/O controller functionality.

Cisco 7200 VXR routers support eight versions of the network processing engine: NPE-G1, NPE-400, NPE-300, NPE-225, NPE-200, NPE-175, NPE-150, and NPE-100. These network processing engines have the same functionality; however, their performance differs because of the microprocessor type and the type of memory for packet data (SRAM and DRAM, or SDRAM) that each network processing engine provides.

Cisco 7200 VXR routers also support the NSE-1, which consists of two modular boards: the processor engine board and the network controller board. The NSE-1 Parallel eXpress Forwarding (PXF) processor works with the Route Processor to provide accelerated packet switching, as well as accelerated IP Layer 3 feature processing.

**Note**

Detailed instructions for removing and replacing the network processing engines or network services engine are contained in the online *Network Processing Engine and Network Services Engine Installation and Configuration* publication. It is also available on the Documentation CD-ROM and on Cisco.com.

The network processing engines and network services engine consist of the following components:

- Reduced instruction set computing (RISC) microprocessor
  - The NPE-G1 uses a BCM 1250 microprocessor that operates at an internal clock speed of 700 MHz.
  - The NSE-1 uses an RM7000 microprocessor that operates at an internal clock speed of 262 MHz.
  - The NPE-400 uses an RM7000 microprocessor that operates at an internal clock speed of 350 MHz.
  - The NPE-300 uses an RM7000 microprocessor that operates at an internal clock speed of 262 MHz.
  - The NPE-225 has an RM5271 microprocessor that operates at an internal clock speed of 262 MHz.
  - The NPE-200 has an R5000 microprocessor that operates at an internal clock speed of 200 MHz.
  - The NPE-175 has an RM5270 microprocessor that operates at an internal clock speed of 200 MHz.

- The NPE-100 and NPE-150 have an R4700 microprocessor that operates at an internal clock speed of 150 MHz.
- System controller
  - The NPE-G1 BCM 1250 maintains and executes the system management functions for the Cisco 7200 VXR routers and also holds the system memory and environmental monitoring functions.
  - The NSE-1 has one system controller that provides processor access to the midplane and single I/O controller PCI buses. The system controller also allows port adapters on either of the two midplane PCI buses to access SDRAM.
  - The NPE-400 has one system controller that provides system access.
  - The NPE-300 has two system controllers that provide processor access to the two midplane and single I/O controller PCI buses. The system controller also allows port adapters on either of the two midplane PCI buses to access SDRAM.
  - The NPE-175 and NPE-225 have one system controller that provides processor access to the two midplane and single I/O controller PCI buses. The system controller also allows the port adapters on either of the two midplane PCI buses to access SDRAM.
  - The NPE-100, NPE-150, and NPE-200 have a system controller that uses direct memory access (DMA) to transfer data between DRAM and packet SRAM on the network processing engine.
- Upgradable memory modules
  - The NPE-G1 uses SDRAM for storing all packets received or sent from network interfaces. The SDRAM also stores routing tables and network accounting applications. Two independent SDRAM memory arrays in the system allow concurrent access by port adapters and the processor.
  - The NSE-1 uses SDRAM for providing code, data, and packet storage.
  - The NPE-400 uses SDRAM for storing all packets received or sent from network interfaces. The SDRAM memory array in the system allows concurrent access by port adapters and the processor.
  - The NPE-300 uses SDRAM for storing all packets received or sent from network interfaces. The SDRAM also stores routing tables and network accounting applications. Two independent SDRAM memory arrays in the system allow concurrent access by port adapters and the processor.
  - The NPE-175 and NPE-225 use SDRAM for providing code, data, and packet storage.
  - The NPE-100, NPE-150, and NPE-200 use DRAM for storing routing tables, network accounting applications, packets of information in preparation for process switching, and packet buffering for SRAM overflow (except in the NPE-100, which contains no packet SRAM). The standard configuration is 32 MB, with up to 128 MB available through single in-line memory module (SIMM) upgrades.
- Packet SRAM for storing packets of information in preparation for fast switching
 

The NPE-150 has 1 MB of SRAM and the NPE-200 has 4 MB of SRAM. No other network processing engine or network services engine has SRAM.
- Cache memory
  - The NPE-G1 has two levels of cache: a primary and a secondary cache that are internal to the microprocessor, with the secondary unified cache for data and instruction.
  - The NSE-1 has three levels of cache: a primary and a secondary unified cache that are internal to the microprocessor, and a tertiary 2-MB external cache.

- The NPE-400 has three levels of cache: a primary and a secondary cache that are internal to the microprocessor, and a tertiary 4-MB external cache that provides additional high-speed storage for data and instructions.
- The NPE-300 has three levels of cache: a primary and a secondary cache that are internal to the microprocessor, and a tertiary 2-MB external cache that provides additional high-speed storage for data and instructions.
- The NPE-225 has two levels of cache: a primary cache that is internal to the processor and a secondary 2-MB external cache that provides additional high-speed storage for data and instructions.
- The NPE-200 has unified cache SRAM that functions as the secondary cache for the microprocessor. (The primary cache is within the microprocessor.)
- The NPE-175 has two levels of cache: a primary cache that is internal to the processor and a secondary 2-MB external cache that provides additional high-speed storage for data and instructions.
- The NPE-150 has unified cache SRAM that functions as the secondary cache for the microprocessor. (The primary cache is within the microprocessor.)
- The NPE-100 has unified cache SRAM that functions as the secondary cache for the microprocessor. (The primary cache is within the microprocessor.)
- Two environmental sensors for monitoring the cooling air as it leaves the chassis
- Boot ROM for storing sufficient code for booting the Cisco IOS software; the NPE-G1, NSE-1, NPE-400, NPE-300, NPE-225, NPE-200, and NPE-175 have boot ROM.

The network processing engines and network services engine perform the following system management functions:

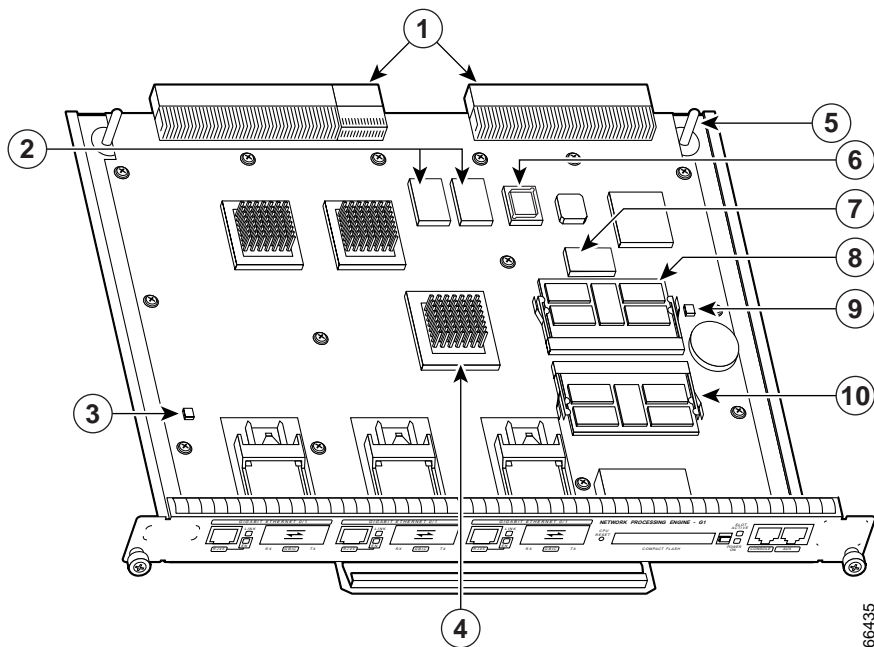
- Sending and receiving routing protocol updates
- Managing tables, caches, and buffers
- Monitoring interface and environmental status
- Providing Simple Network Management Protocol (SNMP) management through the console and Telnet interface
- Accounting for and switching of data traffic
- Booting and reloading images
- Managing port adapters (recognition and initialization during online insertion and removal)

The following figures and memory tables provide information about your NPE or NSE:

- NPE-G1 is represented by [Figure 1-5](#). [Table 1-2](#) lists NPE-G1 memory specifications, and [Table 1-3](#) lists memory configurations.
- NSE-1 is represented by [Figure 1-6](#). [Table 1-4](#) lists NSE-1 memory specifications, and [Table 1-5](#) lists memory configurations.
- The NPE-400 is represented by [Figure 1-7](#). [Table 1-6](#) lists NPE-400 memory specifications, and [Table 1-7](#) lists memory configurations.
- NPE-300 is represented by [Figure 1-8](#). [Table 1-8](#) lists NPE-300 memory specifications, and [Table 1-9](#) lists memory configurations.
- NPE-225 is represented by [Figure 1-9](#). [Table 1-10](#) lists NPE-225 memory specifications, and [Table 1-11](#) lists memory configurations.

- NPE-200 is represented by [Figure 1-10](#). [Table 1-12](#) lists NPE-200 memory specifications, and [Table 1-13](#) lists memory configurations.
- NPE-175 is represented by [Figure 1-11](#). [Table 1-14](#) lists NPE-175 memory specifications, and [Table 1-15](#) lists memory configurations.
- NPE-150 is represented by [Figure 1-12](#). [Table 1-16](#) lists NPE-150 memory specifications, and [Table 1-17](#) lists memory configurations.
- NPE-100 is represented by [Figure 1-13](#). [Table 1-18](#) lists NPE-100 memory specifications, and [Table 1-19](#) lists memory configurations.

**Figure 1-5 NPE-G1**



1	Midplane connectors	6	Boot ROM
2	Flash memory	7	NVRAM
3	Temperature sensor	8	DIMM 2
4	Processor	9	Temperature sensor
5	Keying post	10	DIMM 1

[Table 1-2](#) lists the NPE-G1 memory specification, and [Table 1-3](#) lists the factory-installed SDRAM configurations and their product numbers.

**Table 1-2 NPE-G1 Memory Specifications**

Memory Type	Size	Quantity	Description	Component Location on the NPE-G1 Board
SDRAM	128 MB, 256 MB, 512 MB	2	128-MB, 256-MB, or 512-MB SODIMMs	J3, J4

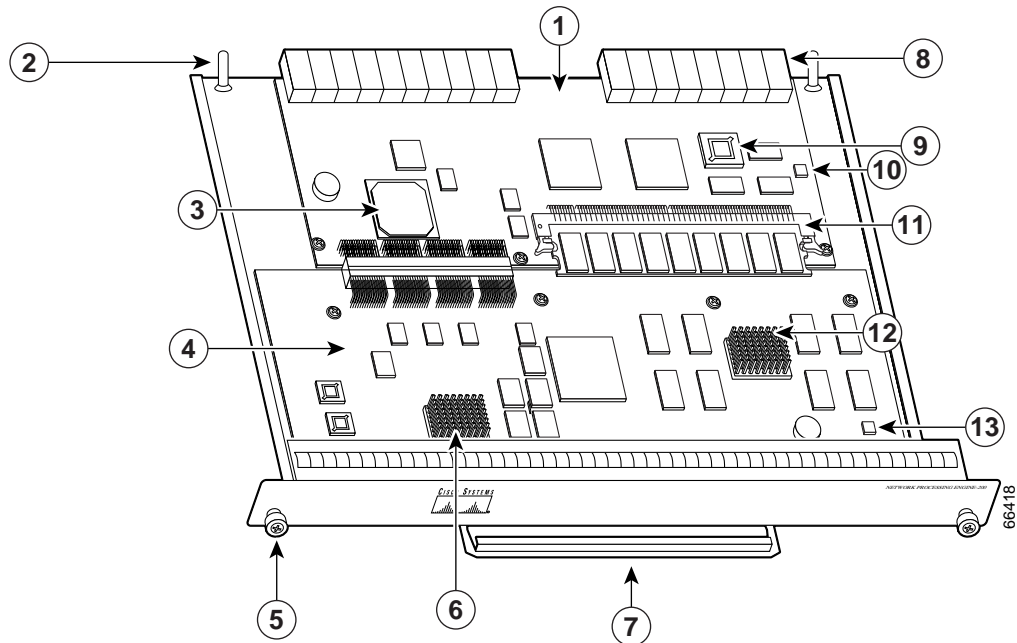
*Table 1-2 NPE-G1 Memory Specifications (continued)*

Boot ROM	512 KB	1	Reprogrammable Boot ROM for the ROM monitor program	U1
Flash Memory	16 MB	1	Contains the default boot helper (boot loader) image	U25 and U26
NVRAM	512 KB	1	Nonvolatile EPROM for the system configuration file	U7
Primary cache	32 KB (16 KB instruction), 16 KB (data)	—	BCM 1250 system, internal cache	U22
Secondary cache	512 KB	—	BCM 1250 system, internal, unified cache	U22

*Table 1-3 NPE-G1 SDRAM SODIMM Memory Configurations—Configurable Memory Only*

Total SDRAM	SDRAM Bank	Quantity	Product Number
256 MB	J3 and J4	2 128-MB SODIMMs	MEM-NPE-G1-256MB=
512 MB	J3 and J4	2 256-MB SODIMMs	MEM-NPE-G1-512MB=
1 GB	J3 and J4	2 512-MB SODIMMs	MEM-NPE-G1-1GB=

Figure 1-6 NSE-1



1	Network controller board	8	Midplane connectors
2	Keying post	9	Boot ROM U1
3	System controller	10	Temperature sensor
4	Processor engine board	11	SDRAM
5	Captive installation screw	12	Parallel eXpress Forwarding engine (PXF processor)
6	RM7000 microprocessor	13	Temperature sensor
7	Handle		

Table 1-4 lists the NSE-1 memory specifications, and Table 1-5 lists the NSE-1 factory-installed SDRAM configurations and their product numbers.

Table 1-4 NSE-1 Memory Specifications

Memory Type	Size	Quantity	Description	Location <sup>1</sup>
SDRAM	128 or 256 MB	1 SDRAM slot	128- or 256-MB DIMM	U15
Boot ROM	512 KB	1	OTP ROM for the ROM monitor program	U1
Primary cache	16 KB (instruction), 16 KB (data)	—	RM7000 processor, primary internal cache	U22



**Table 1-4 NSE-1 Memory Specifications (continued)**

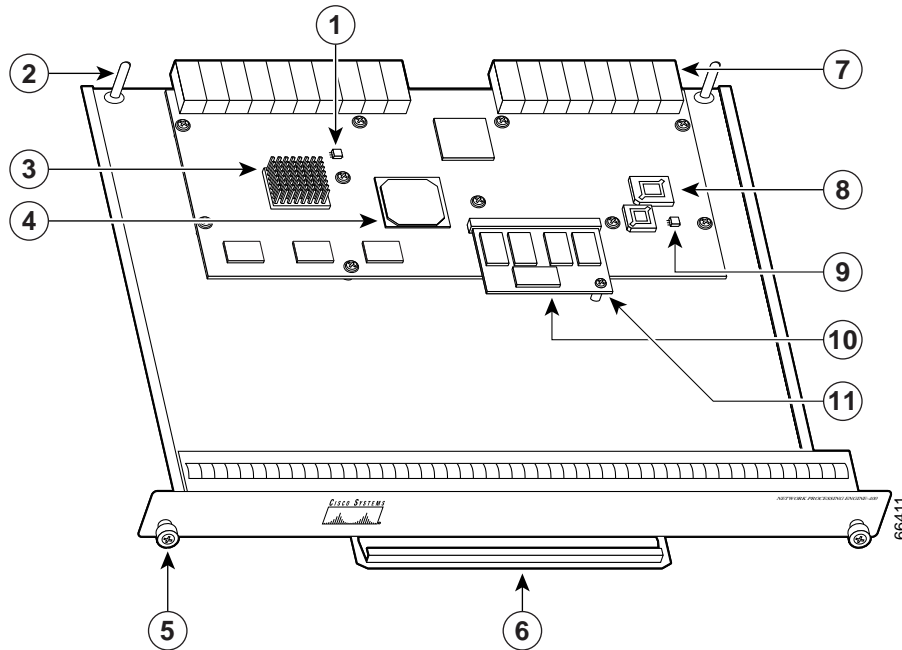
Memory Type	Size	Quantity	Description	Location <sup>1</sup>
Secondary cache	256 KB	—	RM7000 processor, internal, unified instruction and data cache	U22
Tertiary cache	2 MB (fixed)	—	RM7000 processor, external cache	U7, U9, U12, U14, U17

1. Location on processing engine board. See [Figure 1-6](#).

**Table 1-5 NSE-1 SDRAM DIMM Memory Configurations**

Total SDRAM	SDRAM Bank	Quantity	Product Number
128 MB	U15	1 128-MB DIMM	MEM-SD-NPE-128MB=
256 MB	U15	1 256-MB DIMM	MEM-SD-NSE-256MB=

**Figure 1-7 NPE-400**



1	Temperature sensor (U31)	7	Midplane connector
2	Keying post	8	Boot ROM (U7)
3	RM7000 microprocessor	9	Temperature sensor
4	System controller	10	SODIMM (J1)
5	Captive installation screw	11	Standoff and screw
6	Handle		

Table 1-6 lists the NPE-400 memory specifications, and Table 1-7 lists factory-installed DRAM configurations and their product numbers.

**Table 1-6 NPE-400 Memory Specifications**

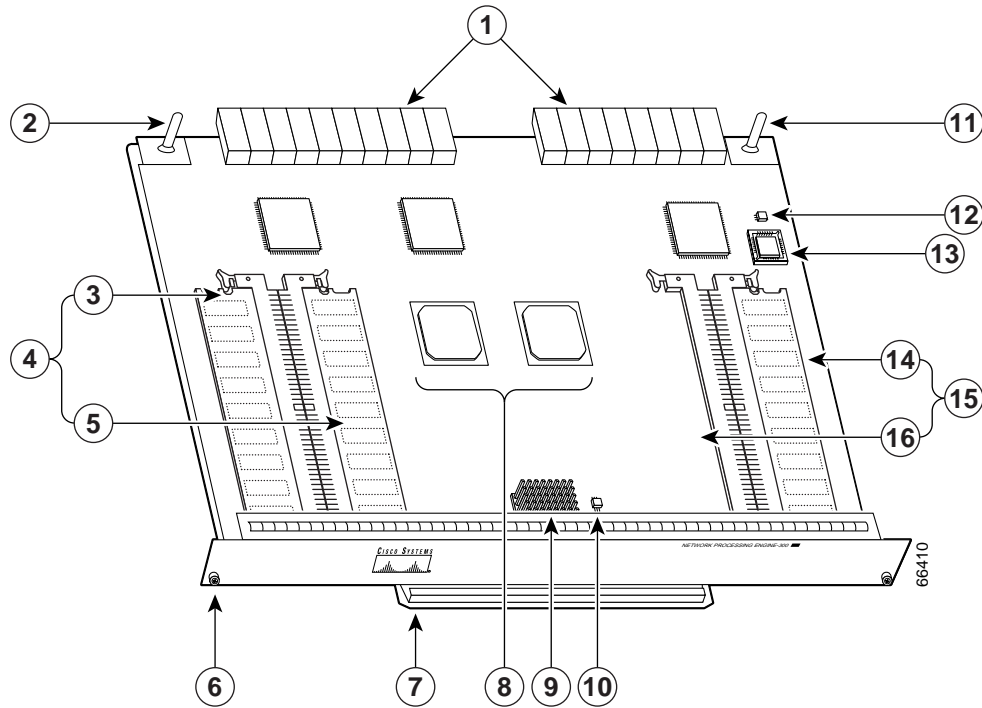
Memory Type	Size	Quantity	Description	Location
SDRAM-configurable	128, 256, or 512 MB	1	128-, 256-, or 512-MB SODIMM	J1
Boot ROM	512 KB	1	OTP <sup>1</sup> ROM for the ROM monitor program	U7
Primary cache	16 KB (instruction), 16 KB (data)	—	RM7000 processor, integrated cache	U38
Secondary cache	256 KB (fixed)	—	RM7000 processor, unified, internal cache	U38
Tertiary cache	4 MB (fixed)	—	RM7000 processor, external cache	U2, U26, U27, U28, U37

1. OTP = one-time programmable

**Table 1-7 NPE-400 SDRAM SODIMM Memory Configurations**

Total SDRAM	Bank 1	Quantity	Product Number
128 MB	J1	1 128-MB SODIMM	MEM-NPE-400-128MB=
256 MB	J1	1 256-MB SODIMM	MEM-NPE-400-256MB=
512 MB	J1	1 512 MB SODIMM	MEM-NPE-400-512MB=

Figure 1-8 NPE-300



1	Midplane connectors	9	RM7000 microprocessor
2	Keying post	10	Temperature sensor (U42)
3	DIMM 3 (U44)	11	Keying post
4	Bank 1 (user configurable)	12	Temperature sensor
5	DIMM 2 (U45)	13	Boot ROM (U1)
6	Captive installation screw	14	DIMM 0 (U16)
7	Handle	15	Bank 0 (fixed size)
8	System controllers	16	U15 never populated

Table 1-8 lists the NPE-300 memory specifications, and Table 1-9 lists factory-installed SDRAM configurations and their product numbers.

Table 1-8 NPE-300 Memory Specifications

Memory Type	Size	Quantity	Description	Location <sup>1</sup>
SDRAM	32 to 256 MB	1 configurable <sup>2</sup> bank with 2 SDRAM slots	32-, 64-, or 128-MB DIMMs (based on maximum SDRAM required)	Bank 1: U45 and U44 <sup>3</sup>
Boot ROM	512 KB	1	OTP <sup>4</sup> ROM for the ROM monitor program	Socket U1
Primary cache	16 KB (instruction), 16 KB (data)	—	RM7000 processor, internal cache	U49

**Table 1-8 NPE-300 Memory Specifications (continued)**

Memory Type	Size	Quantity	Description	Location <sup>1</sup>
Secondary cache	256 KB	—	RM7000 processor, internal, unified instruction and data cache	U49
Tertiary cache	2 MB (fixed)	—	RM7000 processor, external cache	U7, U8, U9, U10, U17

1. Location on processing engine board. See [Figure 1-8](#).
2. Bank 0 is used exclusively for packet memory and is not user configurable.
3. Bank 1 contains the Cisco IOS software, processor memory, and packet memory.
4. OTP = one-time programmable

**Note**

The NPE-300 contains two banks of SDRAM. Both SDRAM banks are used for all packet memory requirements; however, bank 0 is used exclusively for packet memory and is set at a fixed configuration in the factory.

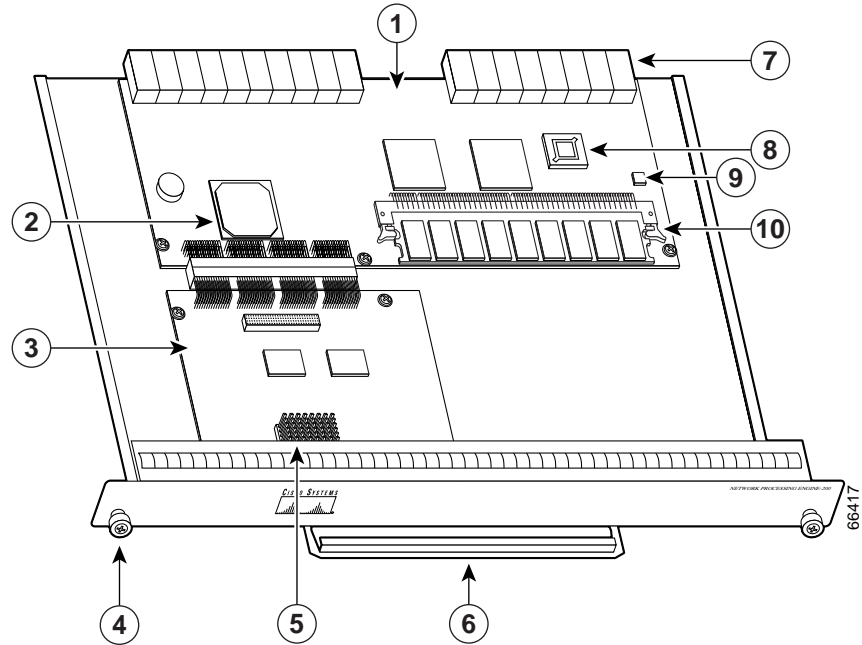
Bank 1 contains two user-configurable SDRAM slots, DIMM slot 2 and DIMM slot 3 (see [Figure 1-8](#)). Both slots in bank 1 can be populated by DIMMs of different sizes; however, the size of the DIMM in slot 2 must be greater than or equal to the size of the DIMM in slot 3, and the size of the DIMM in slot 3 can be zero.

**Table 1-9 NPE-300 SDRAM DIMM Memory Configurations**

Total SDRAM	SDRAM Bank 1 <sup>1</sup>	Quantity	Product Number <sup>2</sup>
32 <sup>3</sup> MB + 32 MB	U45 (DIMM slot 2 only)	1 32-MB DIMM	MEM-SD-NPE-32MB=
32 <sup>3</sup> MB + 64 MB	U45 and U44	2 32-MB DIMMs	MEM-SD-NPE-32MB=
	or U45	or 1 64-MB DIMM	MEM-SD-NPE-64MB=
32 <sup>3</sup> MB + 128 MB	U45 and U44	2 64-MB DIMMs	MEM-SD-NPE-64MB=
	or U45	or 1 128-MB DIMM	MEM-SD-NPE-128MB=
32 <sup>3</sup> MB + 256 MB	U45 and U44	2 128-MB DIMMs	MEM-SD-NPE-128MB=

1. There are two user-upgradable SDRAM slots in bank 1. (Bank 0 is used exclusively for packet memory and is set at a fixed configuration in the factory.)
2. These products are also available as SDRAM upgrades. To order an upgrade, add an equal sign (=) after the product number, for example, MEM-SD-NPE-128MB=.
3. This 32 MB is fixed memory in SDRAM bank 0, socket U16. Socket U15 is never populated.

Figure 1-9 NPE-225



1	Network controller board	6	Handle
2	System controller	7	Midplane connectors
3	Processor engine board	8	Boot ROM (U1)
4	Captive installation screw	9	Temperature sensor
5	RM5271 microprocessor	10	SDRAM DIMM (U15)

Table 1-10 lists the NPE-225 memory specifications, and Table 1-11 lists factory-installed SDRAM configurations and their product numbers.

**Table 1-10 NPE-225 Memory Specifications**

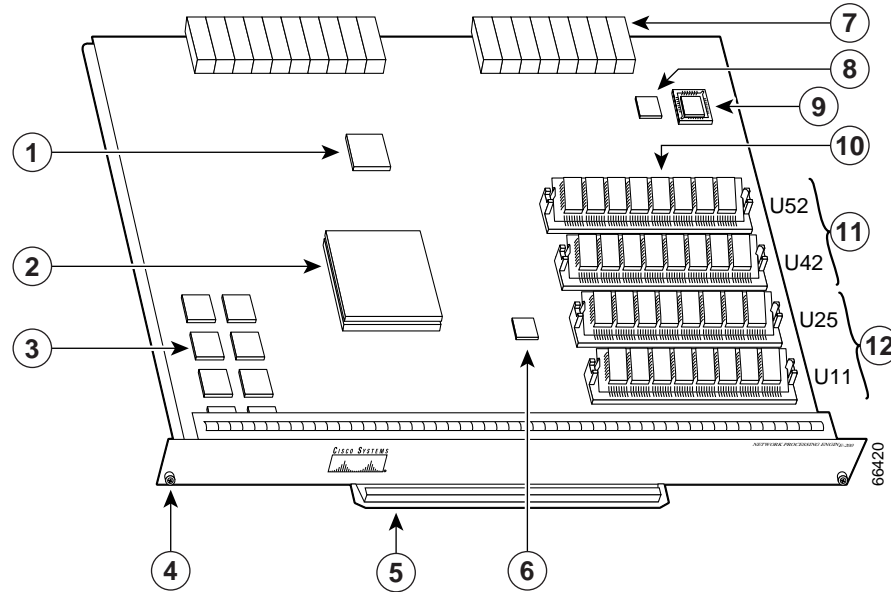
Memory Type	Size	Quantity	Description	Location <sup>1</sup>
SDRAM	64 or 128 MB	1 SDRAM slot	64- or 128-MB SDRAM DIMM	U15
Boot ROM	512 KB	—	One-time programmable ROM	U1
Primary cache	16 KB (instruction), 16 KB (data)	—	RM527x processor, internal cache	U4
	32 KB (instruction), 32 KB (data)	—	RM527x processor, internal cache	U4
Secondary cache	2 MB	4 chips, each 512K by 8 bits wide	RM527x processor, unified external cache	U5, U6, U7, U8

1. Location on processing engine board. See [Figure 1-9](#).

**Table 1-11 NPE-225 SDRAM DIMM Memory Configurations**

Total SDRAM	Bank	Quantity	Product Number
64 MB	U15	1 64-MB DIMM	MEM-SD-NPE-64MB=
128 MB	U15	1 128-MB DIMM	MEM-SD-NPE-128MB=
256 MB	U15	1 256-MB DIMM	MEM-SD-NSE-256MB=

Figure 1-10 NPE-200



1	System controller	7	Midplane connectors
2	R5000 microprocessor	8	Temperature sensor
3	4-MB SRAM (U6, U10, U13, U14, U28, U29, U38, and U39)	9	Boot ROM (U92)
4	Captive installation screw	10	DRAM SIMMs
5	Handle	11	Bank 1
6	Temperature sensor	12	Bank 2

Table 1-12 lists the NPE-200 memory specifications, and Table 1-13 lists factory-installed DRAM configurations and their product numbers.

Table 1-12 NPE-200 Memory Specifications

Memory Type	Size	Quantity	Description	Location <sup>1</sup>
DRAM	32 to 128 MB	2 to 4	16- or 32-MB SIMMs (based on maximum DRAM required)	Bank 0: U11 and U25 Bank 1: U42 and U52
SRAM	4 MB	8	8 chips, each being 512K words x 8 bits wide	U6, U10, U13, U14, U28, U29, U38, and U39
Boot ROM <sup>2</sup>	256 KB	1	EPROM for the ROM monitor program	U92

*Table 1-12 NPE-200 Memory Specifications (continued)*

Memory Type	Size	Quantity	Description	Location <sup>1</sup>
Primary cache	—	—	R5000 processor, internal cache	U44
Secondary cache	512 KB	4	R5000 processor, unified external cache	U16, U9, U109, and U107

1. Location on processing engine board. See [Figure 1-10](#).
2. ROM = read-only memory.

**Note**

To prevent DRAM errors in the NPE-100, NPE-150, or NPE-200, and to ensure that your system initializes correctly at startup, DRAM bank 0 (socket U18 and U25, or U11 and U25) *must* contain no fewer than two SIMMs of the same type. You may also install two SIMMs of the same type in bank 1 (socket U4 and U12, or U42 and U52); however, bank 0 must always contain the two largest size SIMMs.

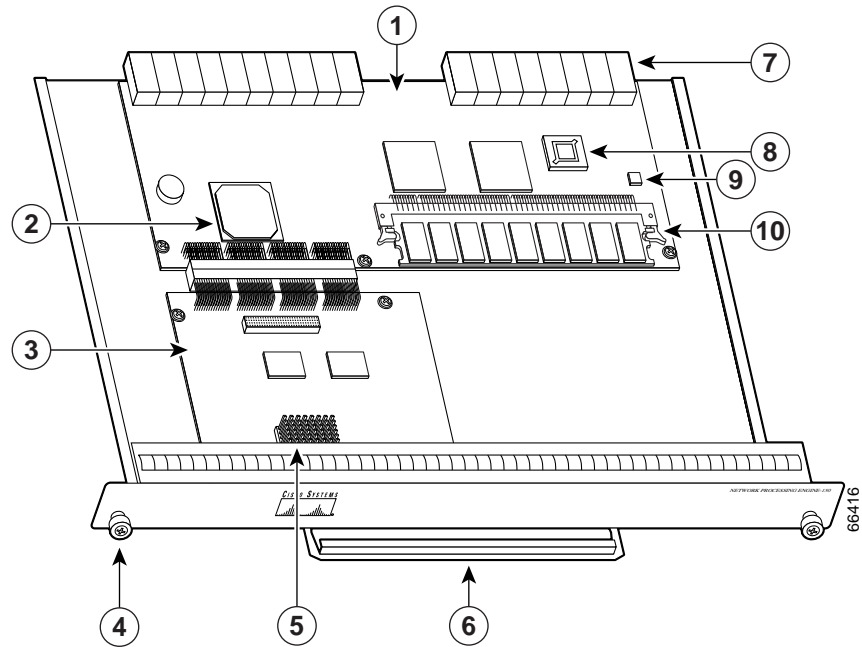
*Table 1-13 NPE-200 DRAM SIMM Memory Configurations*

Total DRAM	DRAM Bank 0	Quantity	DRAM Bank 1	Quantity	Product Number <sup>1</sup>
32 MB	U11 and U25	2 16-MB SIMMs	U42 and U52	—	MEM-NPE-32MB=
64 MB	U11 and U25	2 32-MB SIMMs	U42 and U52	—	MEM-NPE-64MB=
128 MB	U11 and U25	2 32-MB SIMMs	U42 and U52	2 32-MB SIMMs	MEM-NPE-128MB=

1. These products are also available as DRAM upgrades. For example to upgrade a network processing engine from 32 MB to 64 MB of DRAM, order product number MEM-NPE-64MB=.



Figure 1-11 NPE-175



1	Network controller board	6	Handle
2	System controller	7	Midplane connectors
3	Processor engine board	8	Boot ROM (U1)
4	Captive installation screw	9	Temperature sensor
5	RM5270 microprocessor	10	SDRAM DIMM (U15)

Table 1-14 lists the NPE-175 memory specifications, and Table 1-15 lists memory configurations.

**Table 1-14 NPE-175 Memory Specifications**

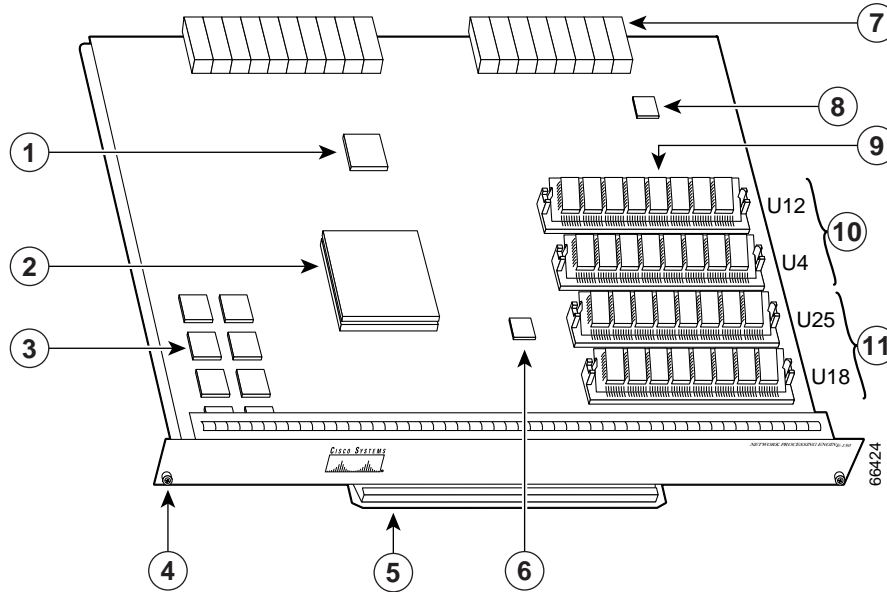
Memory Type	Size	Quantity	Description	Location <sup>1</sup>
SDRAM	64 or 128 MB	1 SDRAM slot	DIMM	U15
Boot ROM	512 KB	—	One-time programmable ROM	U1
Primary cache	16 KB (instruction), 16 KB (data)	—	RM527x processor, internal cache	U4
	32 KB (instruction), 32 KB (data)	—	RM527x processor, internal cache	U4
Secondary cache	2 MB	4 chips, each 512K by 8 bits wide	RM527x processor, unified external cache	U5, U6, U7, U8

1. Location on processing engine board. See [Figure 1-11](#).

**Table 1-15 NPE-175 SDRAM DIMM Memory Configurations**

Total SDRAM	SDRAM Bank	Quantity	Product Number
64 MB	U15	1 64-MB DIMM	MEM-SD-NPE-64MB=
128 MB	U15	1 128-MB DIMM	MEM-SD-NPE-128MB=

Figure 1-12 NPE-150



1	System controller	7	Midplane connectors
2	R4700 microprocessor	8	Temperature sensor
3	1-MB SRAM (U700 through U703, U800 through U803)	9	DRAM SIMMs
4	Captive installation screw	10	Bank 1
5	Handle	11	Bank 0
6	Temperature sensor		

Table 1-16 lists the NPE-150 memory specifications, and Table 1-17 lists memory configurations.

Table 1-16 NPE-150 Memory Specifications

Memory Type	Size	Quantity	Description	Location <sup>1</sup>
DRAM	32 to 128 MB	2 to 4	16- or 32-MB SIMMs (based on maximum DRAM required)	Bank 0: U18 and U25 Bank 1: U4 and U12
SRAM	1 MB	8	8 chips, each being 128K words x 9 bits wide	U700 through U703 U800 through U803
Boot ROM	The NPE-150 uses the boot ROM present on the I/O controller.			
Primary cache	—	—	R4700 processor, internal cache	U201
Secondary cache	512 KB	4	R4700 processor, unified external cache	U2, U10, U14, and U26

1. Location on processing engine board. See Figure 1-12.

**Note**

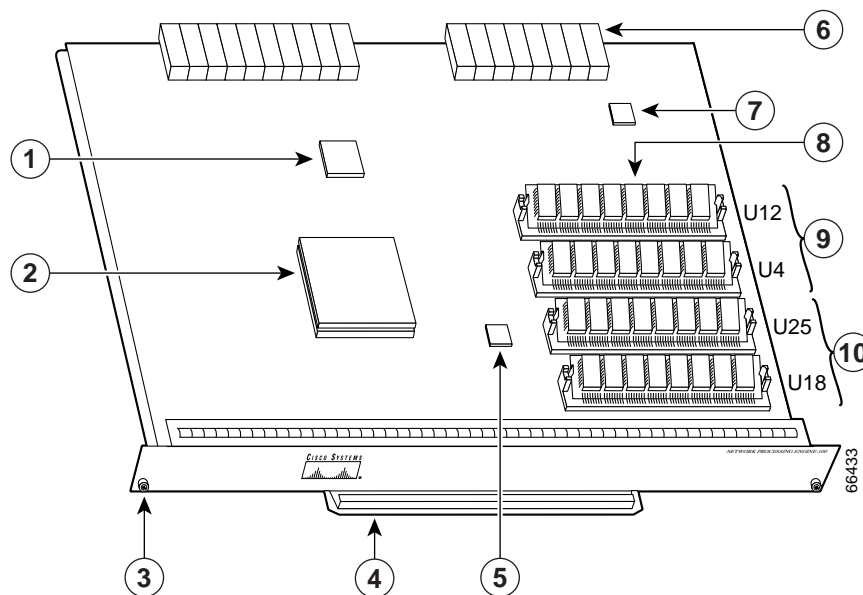
To prevent DRAM errors in the NPE-100, NPE-150, or NPE-200, and to ensure that your system initializes correctly at startup, DRAM bank 0 (socket U18 and U25, or U11 and U25) *must* contain no fewer than two SIMMs of the same type. You may also install two SIMMs of the same type in bank 1 (socket U4 and U12, or U42 and U52); however, bank 0 must always contain the two largest size SIMMs.

**Table 1-17 NPE-150 DRAM SIMM Memory Configurations**

Total DRAM	DRAM Bank 0	Quantity	DRAM Bank 1	Quantity	Product Number <sup>1</sup>
32 MB	U18 and U25	2 16-MB SIMMs	U4 and U12	—	MEM-NPE-32MB=
64 MB	U18 and U25	2 32-MB SIMMs	U4 and U12	—	MEM-NPE-64MB=
128 MB	U18 and U25	2 32-MB SIMMs	U4 and U12	2 32-MB SIMMs	MEM-NPE-128MB=

1. These products are also available as DRAM upgrades. For example, to upgrade a network processing engine from 32 MB to 64 MB of DRAM, order product number MEM-NPE-64MB=.

**Figure 1-13 NPE-100**



1	System controller	6	Midplane connectors
2	R4700 microprocessor	7	Temperature sensor
3	Captive installation screw	8	DRAM SIMMs
4	Handle	9	Bank 1
5	Temperature sensor	10	Bank 0

Table 1-18 lists the NPE-100 network processing engine memory specifications, and Table 1-19 lists memory configurations.

**Table 1-18 NPE-100 Memory Specifications**

Memory Type	Size	Quantity	Description	Location <sup>1</sup>
DRAM	32 to 128 MB	2 to 4	16- or 32-MB SIMMs (based on maximum DRAM required)	Bank 0: U18 and U25 Bank 1: U4 and U12
Boot ROM	The NPE-100 uses boot ROM present on the I/O controller.			
Primary cache	—	—	R4700 processor, internal cache	U201
Secondary cache	512 KB	4	R4700 processor, unified, external cache	U2, U10, U14, and U26

1. Location on processing engine board. See [Figure 1-13](#).

**Note**

To prevent DRAM errors in the NPE-100, NPE-150, or NPE-200, and to ensure that your system initializes correctly at startup, DRAM bank 0 (socket U18 and U25, or U11 and U25) *must* contain no fewer than two SIMMs of the same type. You may also install two SIMMs of the same type in bank 1 (socket U4 and U12, or U42 and U52); however, bank 0 must always contain the two largest size SIMMs.

**Table 1-19 NPE-100 DRAM SIMM Memory Configurations**

Total DRAM	DRAM Bank 0	Quantity	DRAM Bank 1	Quantity	Product Number <sup>1</sup>
32 MB	U18 and U25	2 16-MB SIMMs	U4 and U12	—	MEM-NPE-32MB
64 MB	U18 and U25	2 32-MB SIMMs	U4 and U12	—	MEM-NPE-64MB
128 MB	U18 and U25	2 32-MB SIMMs	U4 and U12	2 32-MB SIMMs	MEM-NPE-128MB

1. These products are also available as DRAM upgrades. For example, to upgrade a network processing engine from 32 MB to 64 MB of DRAM, order product number MEM-NPE-64MB=.

To determine the memory configuration of your Cisco 7200 VXR router, use the **show version** command. The following example shows an NPE-G1 installed in a Cisco7206VXR router:

```
Router# show version
Cisco Internetwork Operating System Software
IOS (tm) 7200 Software (C7200-JS-M),
Released Version 12.2(20011220:181136) [biff]
Copyright (c) 1986-2001 by cisco Systems, Inc.
Compiled Fri 21-Dec-01 05:58 by
Image text-base:0x600089B8, data-base:0x6196E000

ROM: System Bootstrap, Version 12.2(20011219:132854)

(display text omitted)

cisco 7206VXR (NPE-G1) processor (revision 0x00) with 245760K/16384K bytes of memory.
Processor board ID 13250983
BCM12500 CPU at 500Mhz, Implementation 1, Rev 0.1, 512KB L2 Cache
6 slot VXR midplane, Version 2.0
```

## Input/Output Controller

This section describes five different models of I/O controllers. These models are distinguished from one another by their Ethernet interface options. [Table 1-20](#) lists the I/O controllers by product number and describes their differences.



### Note

For a description of the configuration commands you need to configure the different interfaces on your I/O controller, refer to the *Input/Output Controller Replacement Instructions* document that shipped with your system.

**Table 1-20 I/O Controller Descriptions**

Product Number	Description
C7200-I/O-GE+E	1 Gigabit Ethernet and 1 Ethernet port; equipped with a GBIC receptacle for 1000 megabits per second (Mbps) operation and an RJ-45 receptacle for 10-Mbps operation. (See <a href="#">Figure 1-14</a> .)
C7200-I/O-2FE/E	2 autosensing Ethernet/Fast Ethernet ports; equipped with 2 RJ-45 receptacles for 10/100-Mbps operation. (See <a href="#">Figure 1-15</a> .)
C7200-I/O-FE <sup>1</sup>	1 Fast Ethernet port; equipped with an MII receptacle and an RJ-45 receptacle for use at 100 Mbps full-duplex or half-duplex operation. Only 1 receptacle can be configured for use at a time. (See <a href="#">Figure 1-16</a> .)
C7200-I/O	Has no Fast Ethernet port. (See <a href="#">Figure 1-18</a> .)
C7200-I/O-FE-MII <sup>2</sup>	1 Fast Ethernet port; equipped with a single MII receptacle. (See <a href="#">Figure 1-20</a> .)

1. The Product Number C7200-I/O-FE does not specify MII because both an MII and an RJ-45 receptacle are included.
2. The I/O controller with the Product Number C7200-I/O-FE-MII has a single MII Fast Ethernet receptacle only. Although still supported by Cisco Systems, this I/O controller with a single MII receptacle is no longer an orderable product as of May 1998.

You can also identify your I/O controller model from a terminal by using the **show diag slot 0** command. (See the “[Viewing Your System Configuration](#)” section on [page 4-19](#).)

The I/O controllers consist of the following components and options:

- Ethernet, Fast Ethernet, or Gigabit Ethernet interface options
- Dual channels for local console and auxiliary ports

The console port has full data communications equipment (DCE) functionality and the auxiliary port has full data terminal equipment (DTE) functionality.

- NVRAM for storing the system configuration and environmental monitoring logs

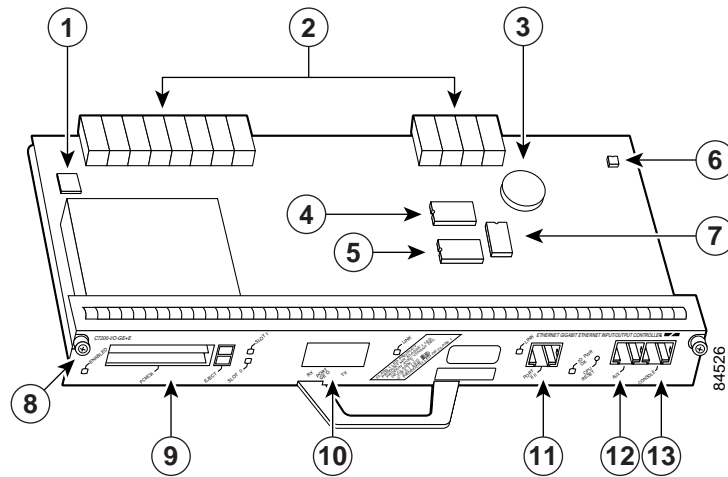


### Note

NVRAM uses lithium batteries to maintain its contents when disconnected from power. Some I/O controllers use a static RAM (SRAM) component with an external lithium battery to provide the same functionality as the NVRAM.

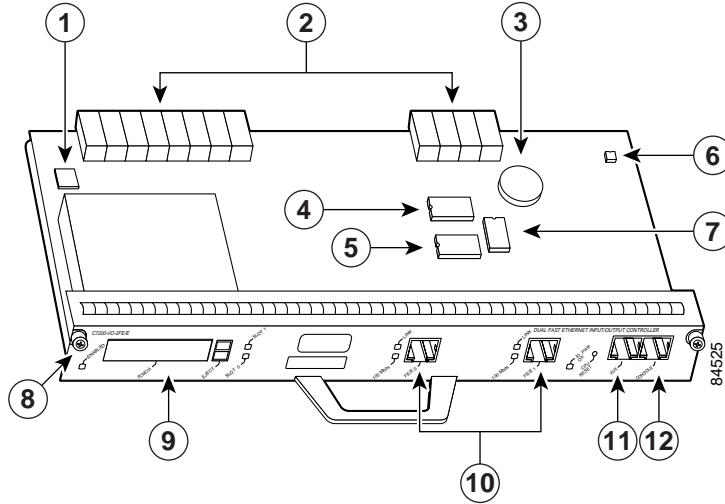
- Two PC Card (PCMCIA) slots that hold Flash Disks or PC cards for storing the default Cisco IOS software image
- Flash memory for storing the boot helper image
- Boot ROM for storing sufficient code for booting the Cisco IOS software
- Two environmental sensors for monitoring the cooling air as it enters and leaves the chassis

*Figure 1-14 C7200-I/O-GE+E—With GBIC Gigabit Ethernet and RJ-45 Ethernet Receptacles*



1	Temperature sensor	8	Captive installation screw
2	Midplane connectors	9	PC Card slots
3	Battery for SRAM	10	Gigabit Ethernet GBIC port
4	8-MB Flash memory (soldered), (U13)	11	Ethernet RJ-45 port
5	8-MB Flash memory (soldered), (U25)	12	Auxiliary port
6	Temperature sensor	13	Console port
7	SRAM (U19)		

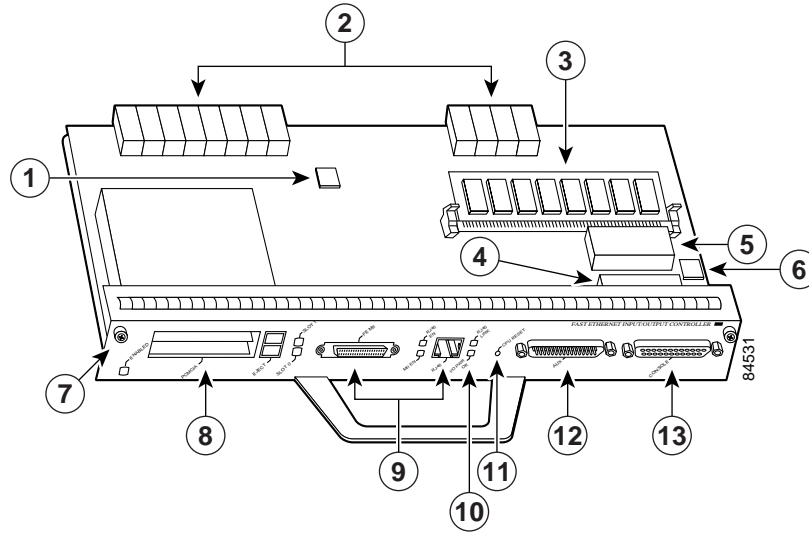
Figure 1-15 C7200-I/O-2FE/E—With Two RJ-45 Ethernet/Fast Ethernet Receptacles



1	Temperature sensor	7	SRAM (U19)
2	Midplane connectors	8	Captive installation screw
3	Battery for SRAM	9	PC Card slots
4	8-MB Flash memory (soldered) (U15)	10	RJ-45 Fast Ethernet ports
5	8-MB Flash memory (soldered) (U25)	11	Auxiliary port
6	Temperature sensor	12	Console port

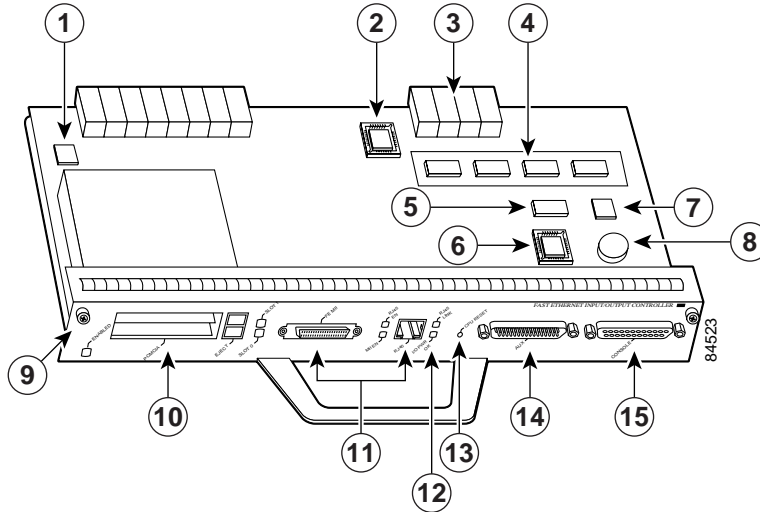


Figure 1-16 C7200-I/O-FE—With MII and RJ-45 Fast Ethernet Receptacles (Version 1)



1	Temperature sensor	8	PC Card slots
2	Midplane connectors	9	Optional Fast Ethernet interface (MII port and RJ-45 port)
3	Flash SIMM (U99)	10	LEDs
4	Boot ROM (U20)	11	CPU reset button
5	NVRAM (U41)	12	Auxiliary port
6	Temperature sensor	13	Console port
7	Captive installation screw		

Figure 1-17 C7200-I/O-FE—With MII and RJ-45 Fast Ethernet Receptacles (Version 2)



1	Temperature sensor	9	Captive installation screw
2	FPGA configuration PROM (U9)	10	PC Card slots
3	Midplane connectors	11	Optional Fast Ethernet interface (MII port and RJ-45 port)
4	4-MB Flash memory (soldered) (U10–U13)	12	LEDs
5	SRAM (U14)	13	CPU reset button
6	Boot EPROM (U4)	14	Auxiliary port
7	Temperature sensor	15	Console port
8	Battery for SRAM		

**Note**

Your I/O controller with the MII and RJ-45 Fast Ethernet receptacles (C7200-I/O-FE) might look like the first illustration in [Figure 1-16](#), or it might look like the second illustration in [Figure 1-16](#). There is no functional difference between these two I/O controllers with the Fast Ethernet port.

**Note**

In the second illustration in [Figure 1-16](#), the NVRAM is replaced by an SRAM component (U14) that is made to act like the NVRAM by the addition of some external components, one of which is the button-type lithium battery labeled “Battery for SRAM.”

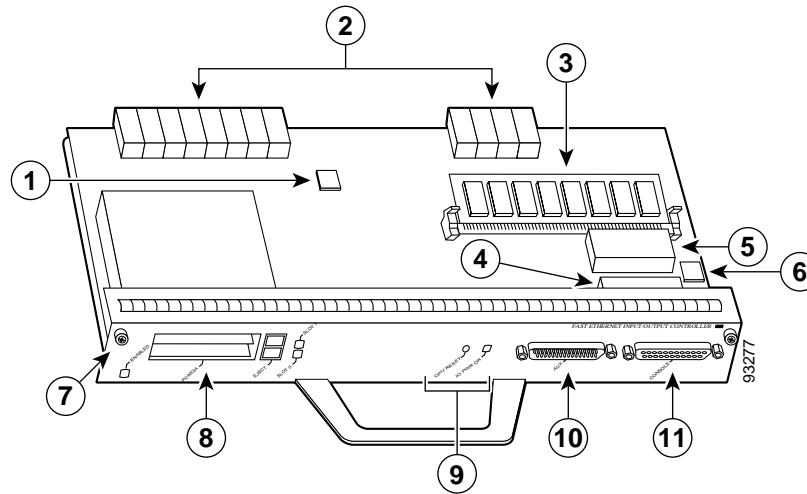
**Note**

Your I/O controller without the Fast Ethernet port (C7200-I/O) might look like the first illustration in [Figure 1-18](#), or it might look like the second illustration in [Figure 1-18](#). There is no functional difference between these two I/O controllers without the Fast Ethernet port.

**Note**

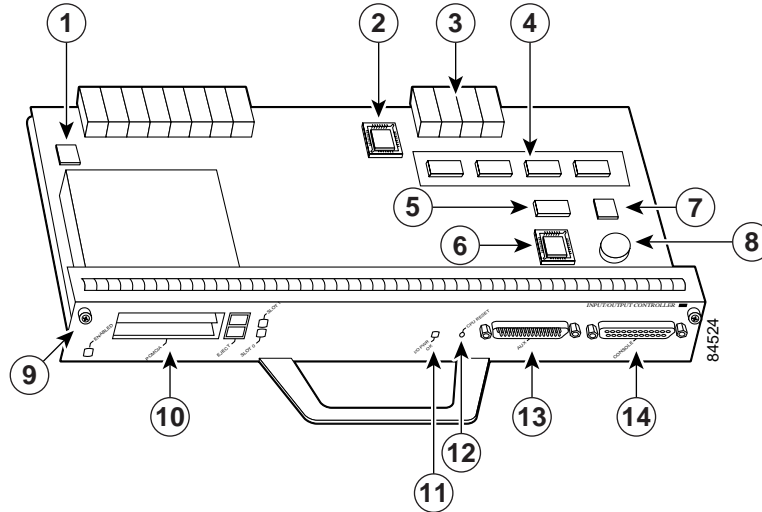
In the second illustration in [Figure 1-18](#), the NVRAM is replaced by an SRAM component (U14) that is made to act like the NVRAM by the addition of some external components, one of which is the button-type lithium battery labeled “Battery for SRAM.”

*Figure 1-18 C7200-I/O—Without Fast Ethernet Port (Version 1)*



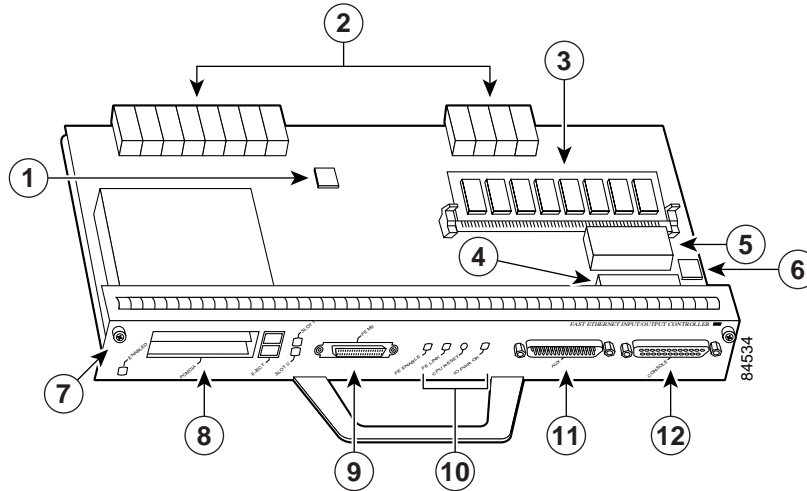
1	Temperature sensor	7	Captive installation screw
2	Midplane connectors	8	PC Card slots
3	Flash SIMM (U99)	9	LED and CPU reset button
4	Boot ROM (U20)	10	Auxiliary port
5	NVRAM (U41)	11	Console port
6	Temperature sensor		

Figure 1-19 C7200-I/O—Without Fast Ethernet Port (Version 2)



1	Temperature sensor	8	Battery for SRAM
2	FPGA configuration PROM (U9)	9	Captive installation screw
3	Midplane connectors	10	PC Card slots
4	4-MB Flash memory (soldered) (U10-U13)	11	LED
5	SRAM (U14)	12	CPU reset button
6	Boot EPROM (U4)	13	Auxiliary port
7	Temperature sensor	14	Console port

Figure 1-20 C7200-I/O-FE-MII—With Single MII Fast Ethernet Receptacle



1	Temperature sensor	7	Captive installation screw
2	Midplane connectors	8	PC Card slots
3	Flash SIMM (U99)	9	Optional Fast Ethernet interface (MII connector)
4	Boot ROM (U20)	10	LEDs and CPU reset button
5	NVRAM (U41)	11	Auxiliary port
6	Temperature sensor	12	Console port

**Note**

C7200-I/O-FE-MII, although still supported by Cisco Systems, was discontinued as an orderable product in May 1998.

Table 1-21 lists the I/O controller memory components.

Table 1-21 I/O Controller Memory Components

Type	Size	Quantity	Memory Description	Model	Location
Boot ROM <sup>1</sup>	256 KB	1	32-pin DIP-type	C7200-I/O-FE-MII	U20
			32-pin DIP-type or 32-pin PLCC-type	C7200-I/O-FE, C7200-I/O	U20 or U4
Flash memory	4 MB	1	Contains the default boot helper image	C7200-I/O-FE-MII	U99
				C7200-I/O-FE, C7200-I/O	U99 or U10, U11, U12, and U13 (soldered) <sup>2</sup>
	8 MB	1		C7200-I/O-GE+E, C7200-I/O-2FE/E	U13 and U25 (soldered) <sup>2</sup>
Flash memory card	16 or 20 MB	Up to 2	Contains the default Cisco IOS image	All models	PC Card slot 0 and slot 1
Flash Disk	32, 48, or 128 MB	Up to 2			
NVRAM	128 KB	1	Nonvolatile EPROM for the system configuration file	C7200-I/O-FE-MII	U41
				C7200-I/O-FE, C7200-I/O	U41 or U14 (soldered) <sup>3</sup>
				C7200-I/O-GE+E, C7200-I/O-2FE/E	U19 (soldered) <sup>3</sup>

1. The C7200-I/O-GE+E and C7200-I/O-2FE/E do not have a boot ROM component.
2. Some I/O controllers have no Flash SIMM but use a permanently soldered 4-MB or 8-MB Flash memory chip instead. (For the location of the 4-MB Flash memory chip, see the second illustration in [Figure 1-16](#) and [Figure 1-18](#). For the location of the 8-MB Flash memory chip, see [Figure 1-14](#) and [Figure 1-15](#).)
3. The NVRAM on some I/O controllers is replaced by a 32-pin nonsocketed SRAM component that is soldered onto the card. The SRAM component is made to act like the NVRAM by the addition of some external components, one of which is a 1-inch (2.54-cm) button-type lithium battery.

## LED Descriptions

All I/O controllers have LEDs, and the NPE-G1 also has interfaces that have LEDs.

The I/O controller faceplate contains LEDs that indicate system and port status; two additional LEDs indicate the status of the Flash Disk or Flash memory cards installed in either PC Card slot. A CPU reset button is located next to the IO POWER OK LED or next to the auxiliary port on the I/O controller faceplate. The CPU reset button resets the entire system.

The NPE-G1 faceplate contains LEDs that indicate system and port status. The RJ-45 and GBIC ports share the same LINK LED because only one of these ports per interface (0/1, 0/2, or 0/3) can be used at any one time. The ENABLE LED is on if the RJ-45 port is in use. The POWER ON LED is on when the system is powered on, whether or not an I/O controller is in the system with the NPE-G1. The SLOT ACTIVE LED is on if there is a CompactFlash Disk in the NPE-G1.

**Caution**

To prevent system errors and problems, use the CPU reset button only at the direction of your service representative.

[Table 1-22](#) lists LEDs common to all models of I/O controllers and describes their functions. [Table 1-23](#) lists LEDs on the NPE-G1.

**Note**

LEDs are either on or off. The LED state (on or off), not the color, determines the status of connection. However, most LEDs are green when on, with the exception of the IO POWER OK LED, which is amber when in the on state.

*Table 1-22 I/O Controller LEDs*

LED	Color	Function
ENABLED	Green	Indicates that the network processing engine or network services engine and the I/O controller are enabled for operation by the system; however, it does not mean that the Fast Ethernet port on the I/O controller is functional or enabled. This LED goes on during a successful router boot and remains on during normal operation of the router.
IO POWER OK	Amber	Indicates that the I/O controller is on and receiving DC power from the router midplane. This LED comes on during a successful router boot and remains on during normal operation of the router.
Slot 0 Slot 1	Green	These LEDs indicate which PC Card slot is in use by coming on when either slot is being accessed by the system. These LEDs remain off during normal operation of the router.

## NPE-G1 LEDs

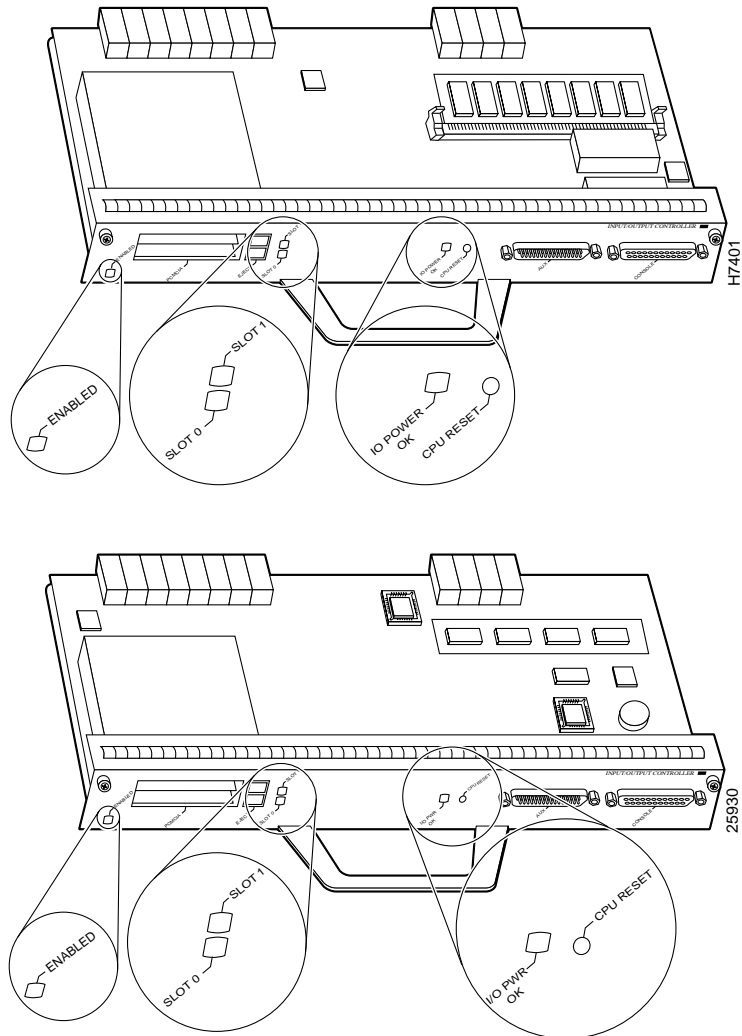
*Table 1-23 NPE-G1 LEDs*

LED Label	LED	Color	LED status in the Power Up state	LED flashes when there is traffic
LINK, 0/1, 0/2, 0/3	RJ-45 and GBIC ports	Green	On, indicating that a link has been established.	No
EN (Enable), 0/1, 0/2, 0/3	RJ-45 ports only	Green	On, if the RJ-45 port is selected. Off, if the GBIC port is selected.	—
SLOT ACTIVE	CompactFlash Disk	Green	On when the slot is being used.	—
POWER ON	Power	Green	On and stays on.	No

## Input/Output Controller C7200-I/O LEDs

[Figure 1-21](#) shows the LEDs on the I/O controller model with no Ethernet ports (C7200-I/O). This I/O controller has no port-specific LEDs. [Table 1-22](#) describes the LEDs on this I/O controller.

Figure 1-21 C7200-I/O LEDs and CPU Reset Button



## Input/Output Controller C7200-I/O-GE+E LEDs

Figure 1-22 shows the LEDs on the I/O controller with the Gigabit Ethernet port and the Ethernet port (C7200-I/O-GE+E), and Table 1-24 lists the LEDs specific to this I/O controller model. Also see Table 1-22 for LEDs common to all I/O controllers.



Figure 1-22 C7200-I/O-GE+E LEDs and CPU Reset Button

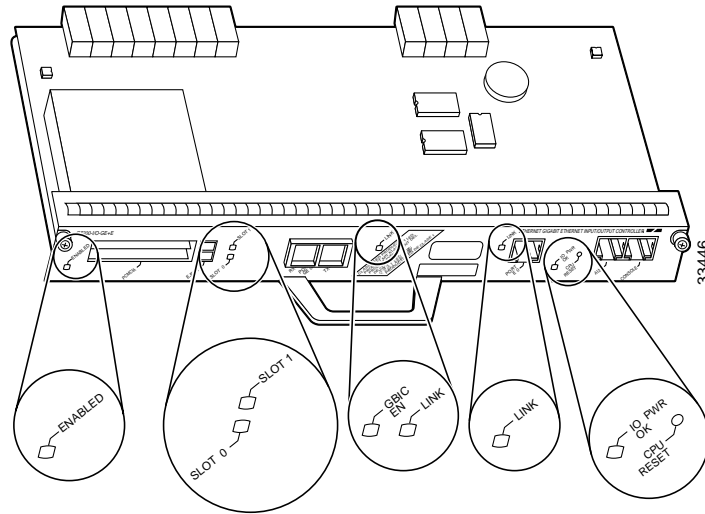


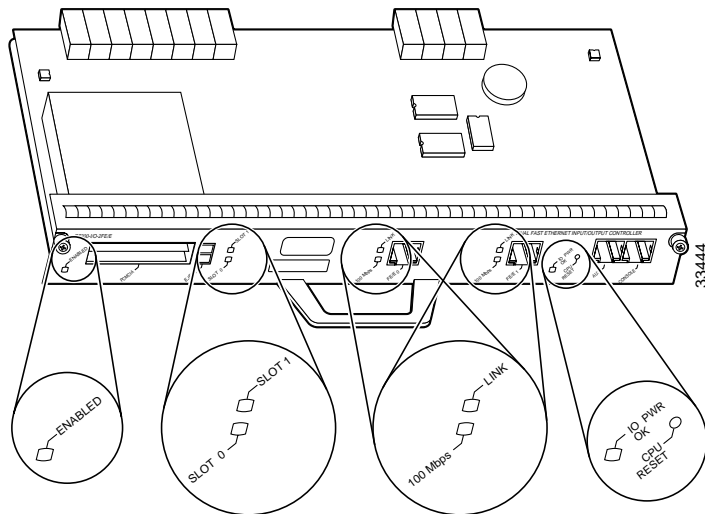
Table 1-24 C7200-I/O-GE+E I/O Controller LEDs

LED	Color	Function
LINK	Green	Indicates that the Ethernet RJ-45 receptacle has established a valid link with the network. This LED remains off during normal operation of the router unless there is an incoming carrier signal.

### Input/Output Controller C7200-I/O-2FE/E LEDs

Figure 1-23 shows the LEDs on the I/O controller with the two autosensing 10/100-Mbps RJ-45 receptacles (C7200-I/O-2FE/E), and Table 1-25 lists the LEDs specific to this I/O controller model. Also see Table 1-22 for LEDs common to all I/O controllers.

Figure 1-23 C7200-I/O-2FE/E LEDs and CPU Reset Button



*Table 1-25 C7200-I/O-2FE/E I/O Controller LEDs*

LED	Color	Function
100 Mbps	Green	Indicates that the port is configured for 100-Mbps operation (speed 100), or if configured for autonegotiation (speed auto), the port has detected a valid link at 100 Mbps.  <b>Note</b> If the port is configured for 10-Mbps operation, or if it is configured for autonegotiation and the port has detected a valid link at 10 Mbps, the LED remains off.
LINK	Green	Indicates that the Ethernet/Fast Ethernet RJ-45 receptacle has established a valid link with the network. This LED remains off during normal operation of the router unless there is an incoming carrier signal.

## Input/Output Controller C7200-I/O-FE LEDs

[Figure 1-24](#) shows the LEDs on the I/O controller with the Fast Ethernet port that is equipped with an MII receptacle and an RJ-45 receptacle (C7200-I/O-FE), and [Table 1-26](#) lists the LEDs specific to this I/O controller model. Also see [Table 1-22](#) for LEDs common to all I/O controllers.

Figure 1-24 C7200-I/O-FE LEDs and CPU Reset Button

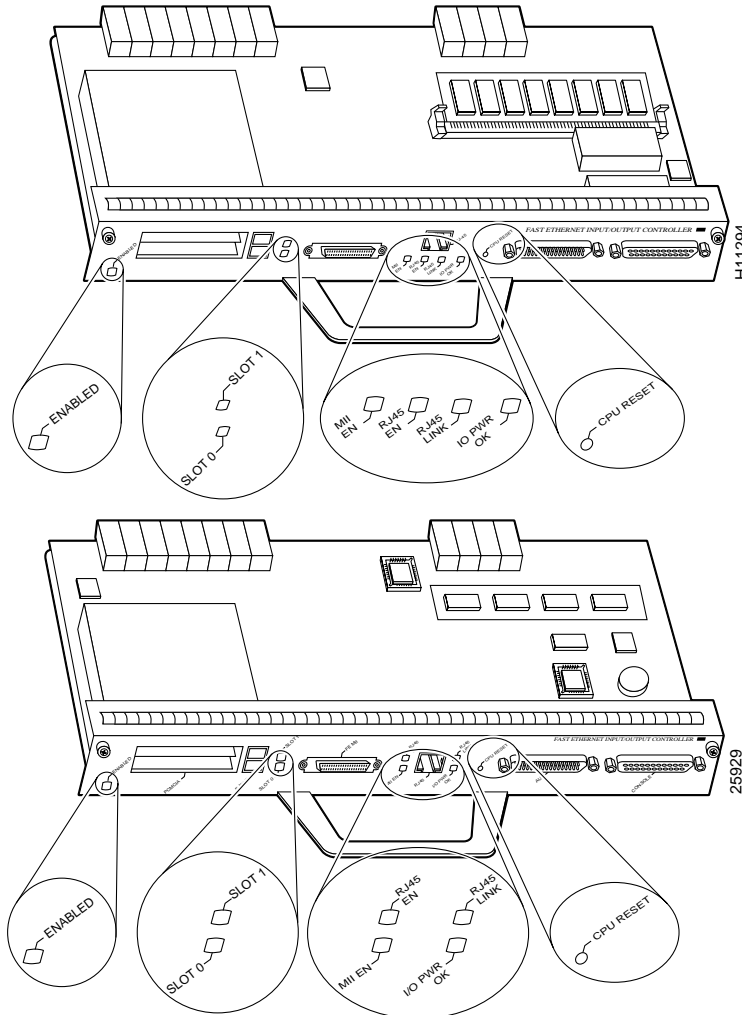


Table 1-26 C7200-I/O-FE I/O Controller LEDs

LED	Color	Function
MII EN	Green	Indicates that the Fast Ethernet MII receptacle is initialized and enabled by the system, and is configured for operation. This LED comes on after the I/O controller has been enabled and the MII receptacle has been configured as the media type for the Fast Ethernet port (the RJ-45 receptacle is the default media type for the Fast Ethernet port). This LED remains on during normal operation of the router.
RJ45 EN	Green	Indicates that the Fast Ethernet RJ-45 receptacle (the default media type for the Fast Ethernet port) is initialized and enabled by the system. This LED comes on after the I/O controller has been enabled and remains on during normal operation of the router.
RJ45 LINK	Green	Indicates that the Fast Ethernet RJ-45 receptacle has established a valid link with the network. This LED remains off during normal operation of the router unless there is an incoming carrier signal.



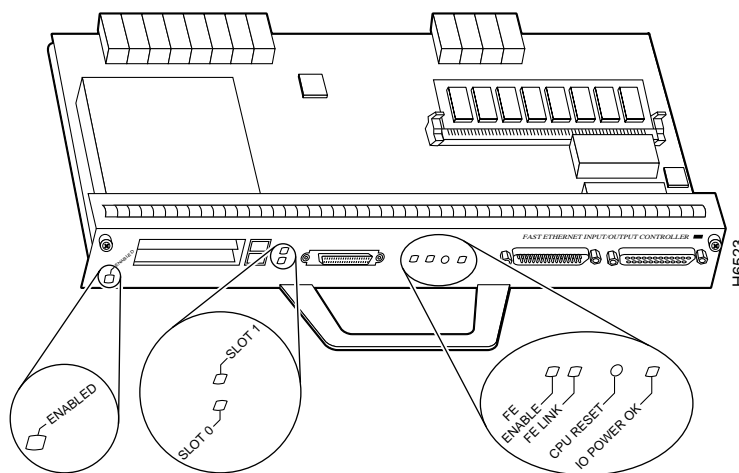
## Note

An MII LINK LED is not provided on this I/O controller because the LED is provided on external transceivers that are required for connecting to the MII receptacle on the I/O controller. See [Chapter 3, “Installing a Cisco 7200 VXR Router,”](#) the “[Connecting to the I/O Controller Ethernet and Fast Ethernet Ports](#)” section on [page 3-25](#) for Fast Ethernet MII connection requirements.

## Input/Output Controller C7200-I/O-FE-MII LEDs

[Figure 1-25](#) shows the LEDs on the I/O controller with the Fast Ethernet port equipped with a single MII receptacle (C7200-I/O-FE-MII), and [Table 1-27](#) lists the LEDs specific to this I/O controller model. Also see [Table 1-22](#) for LEDs common to all I/O controllers.

*Figure 1-25 C7200-I/O-FE-MII LEDs and CPU Reset Button*



*Table 1-27 C7200-I/O-FE-MII I/O Controller LEDs*

LED	Color	Function
FE ENABLE	Green	Indicates that the Fast Ethernet port is initialized and enabled for operation by the system. This LED comes on after the I/O controller has been enabled and remains on during normal operation of the router.
FE LINK	Green	Indicates that the Fast Ethernet port has established a valid link with the network. This LED remains off during normal operation of the router unless there is an incoming carrier signal.

## Port Adapters and Service Adapters

The port adapters and service adapters installed in the Cisco 7200 VXR routers are of the same type as those installed on the second-generation Versatile Interface Processors (VIPs) in the Cisco 7500 series routers, in Cisco 7000 series routers with the Cisco 7000 series Route Switch Processor (RSP7000) and Cisco 7000 series Chassis Interface (RSP7000CI), in the Cisco AS5800 Universal Access Server, and in the Cisco uBR7246 universal broadband router.

**Note**

The port adapters installed in the Cisco 7200 VXR routers support OIR. For an explanation of OIR, see the [“Online Insertion and Removal”](#) section on page 1-53.

All port adapters and service adapters connect to two Peripheral Component Interconnect (PCI) buses on the router midplane. The PCI buses provide a path to packet I/O memory and the system (route/switch) processor. The Fast Ethernet port on the I/O controller connects to a third PCI bus for packet routing and switching. The port or service adapters either provide such services as compression or encryption, or they provide network interfaces to connect the router to external networks.

**Note**

Detailed instructions for removing, replacing, and configuring the port adapter types supported on the Cisco 7200 VXR routers are contained in the configuration note for the port adapter. For example, if you plan to replace a 4-port Ethernet port adapter in your Cisco 7200 VXR router, refer to the configuration note *PA-4E Ethernet 10BaseT Port Adapter Installation and Configuration*. This configuration note accompanies every PA-4E port adapter that is shipped from the factory as an installed item in a Cisco 7200 VXR router or as a FRU. The configuration note is also available on the Documentation CD-ROM and on Cisco.com.

**Caution**

To ensure adequate airflow across the router’s port adapters, a port adapter or a blank port adapter must be installed in each port adapter slot.

## Power Supplies

The Cisco 7200 VXR routers come equipped with one 280W AC-input power supply. (A 280W DC-input power supply is available as an option.) You must order the second power supply separately. A second power supply, although not required, allows load sharing and increased system availability.

**Note**

The Cisco 7200 VXR power supplies are the same as in all Cisco 7200 series routers.

**Caution**

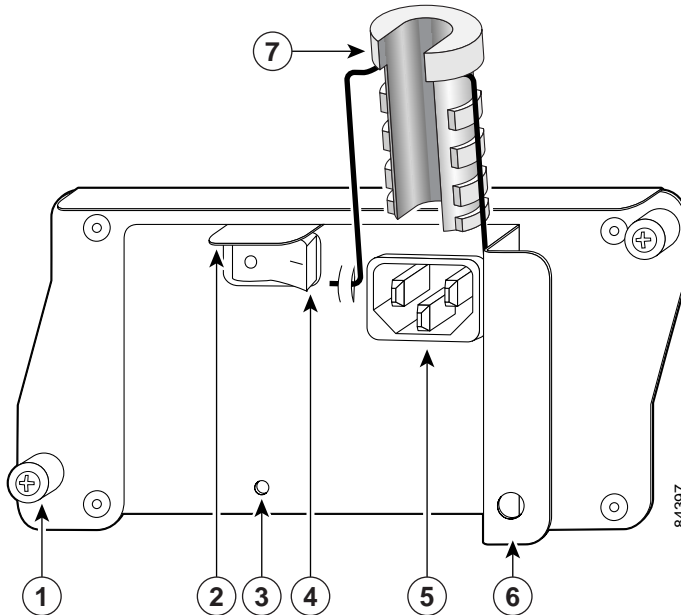
Do not mix power supplies in Cisco 7200 VXR routers. In dual power supply configurations, both power supplies *must* be of the same type (two AC-input power supplies or two DC-input power supplies).

**Note**

Detailed instructions for handling and replacing the Cisco 7200 series power supplies are contained in the configuration notes *280-Watt AC-Input Power Supply Replacement Instructions* and *280-Watt DC-Input Power Supply Replacement Instructions*. These configuration notes accompany every 280W AC-input power supply and every 280W DC-input power supply that is shipped from the factory as a FRU. These configuration notes are also available on the Documentation CD-ROM and on Cisco.com.

A handle on the AC and DC power supplies provides a grip point for removing and replacing the power supply. (Figure 1-26 shows the faceplate of the AC-input power supply. Figure 1-27 shows the faceplate of the DC-input power supply.) Two captive installation screws secure the power supply to the chassis and seat the power supply in the router midplane. A power OK LED indicates that the power supply is delivering +5 VDC to the router midplane.

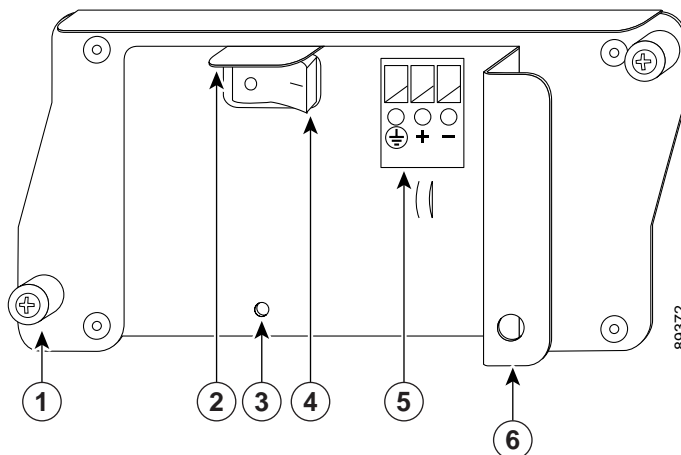
Figure 1-26 Cisco 7200 Series AC-Input Power Supply



1	Captive installation screw	5	AC-input receptacle
2	Power switch guard	6	Handle
3	OK LED	7	Power cable retention-clip
4	Power switch		

The AC-input power supply has a receptacle for an AC-input power cable. A modular power cable connects the AC-input power supply to the site AC power source. A cable-retention clip secures the power cable to the AC-input power supply.

Figure 1-27 Cisco 7200 Series DC-Input Power Supply



1	Captive installation screw	4	Power switch
2	Power switch guard	5	DC-input receptacle
3	OK LED	6	Handle

The DC-input power supply has DC-input power leads that are hardwired to a DC-input terminal block. A cable tie is shipped with each DC-input power supply to secure the leads to the power supply faceplate and provide strain relief for the leads.

**Caution**

To ensure adequate airflow across the router power supplies, a power supply or a power supply filler plate must be installed in each power supply bay. [Figure 1-4](#) shows a Cisco 7206VXR with an installed power supply filler plate.

[Table 1-1](#), earlier in this chapter, lists the AC-input and DC-input power supply system power specifications, including input voltage and operating current ratings.

**Note**

Each AC-input power supply operating at 120 VAC requires a minimum of 5A service. We recommend powering the Cisco 7206VXR from a 15A receptacle at the power source.

**Note**

Each DC-input power supply operating at –24 VDC in North America requires a minimum of 19A service. Each DC-input power supply operating at –48 VDC in North America requires a minimum of 13A service. Each DC-input power supply operating at –60 VDC in the European Community requires a minimum of 8A service.

This product relies on the building's installation for short-circuit (overcurrent) protection. Ensure that a listed and certified fuse or circuit breaker, 20A minimum 60 VDC, is used on all current-carrying conductors. Site wiring and circuit breakers need to be sized to accommodate the maximum values for safety reasons.

The power OK LED goes off and the power supply shuts itself down when the internal DC voltages exceed allowable tolerances or the internal temperature of the power supply exceeds allowable tolerances. The power supply remains in a shutdown state until it is disconnected and reconnected to the source power, and then restarted with the power switch. The power switch turns the power supply on and starts the system. For a description of power supply shutdown conditions and thresholds, see the [“Environmental Monitoring and Reporting Functions”](#) section on page 1-54.

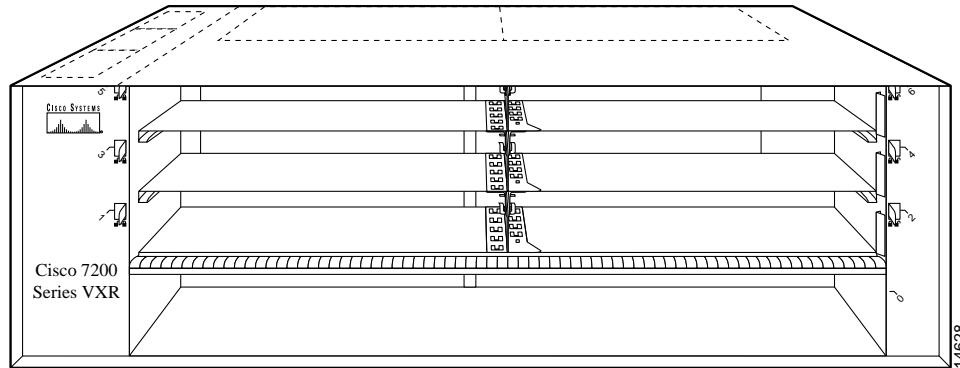
## Chassis

The Cisco 7200 VXR chassis, shown in [Figure 1-28](#), has four or six slots for the port adapters (depending on your chassis model), one slot for the I/O controller, and one bay for the subchassis. The subchassis assembly contains the midplane, the fan tray, two power supply bays, and one slot for the network processing engine. The replacement chassis includes the subchassis assembly and one power supply.

**Note**

To replace the chassis, you must remove and replace all the port adapters, the I/O controller, and the network processing engine or network services engine; therefore, when replacing the chassis, refer to the configuration notes that explain how to remove and replace these units. These configuration notes accompany every chassis that is shipped from the factory as a FRU. The configuration notes are also available on the Documentation CD-ROM and on Cisco.com.

Figure 1-28 Cisco 7200 VXR Chassis—7206VXR Shown



## CompactFlash Disks, Flash Disks and PC Cards

The Cisco 7206VXR supports up to two installed Flash Disks or two PC Cards, also called Flash memory cards. The NPE-G1 supports one CompactFlash Disk.



### Note

To avoid potential problems when you install spare Flash Disks or PC Cards in your Cisco 7206VXR, we recommend that you reformat all your Flash Disks or PC Cards on a Cisco 7206VXR that is running the Cisco IOS release recommended for your system (see [Table 1-1](#)) during your regularly scheduled service times. The online document *Memory Replacement Instructions for the Network Processing Engine or Network Services Engine and the Input/Output Controller* explains how to reformat a PC Card.

With Flash memory (Flash Disks, PC Cards, and the Flash SIMM on the I/O controller, or the CompactFlash Disk on the NPE-G1) you can remotely load and store multiple system and boot helper images. You can download a new image over the network, and then add the new image to Flash memory or replace existing files. You can also transfer images between Flash Disks or PC Cards and the onboard Flash memory SIMM. You can then boot the router either manually or automatically from any of the stored images. Flash memory can also function as a TFTP server to allow other routers to boot remotely from stored images or copy them into their own Flash memory.



### Note

For procedures that explain the use of the Flash Disk or CompactFlash Disk, refer to the online *Using the Flash Disk* document.

For procedures that explain how to replace the main, Flash, and ROM monitor memory, refer to the *Memory Replacement Instructions for the Network Processing Engine or Network Services Engine and the Input/Output Controller* document that shipped with your system. Documents are also available on the Documentation CD-ROM and on Cisco.com.

For NPE-G1 pre-installation information, which requires copying the running configuration from the I/O controller to a Flash Disk or TFTP server before inserting the NPE-G1 into the Cisco 7200 VXR router, see the *Network Processing Engine or Network Services Engine Installation and Configuration* document at <http://www.cisco.com/univercd/cc/td/doc/product/core/7206/fru/npense/index.htm>.



Table 1-28 lists the factory-installed Flash memory card options and their product numbers, and Table 1-29 lists the Flash Disk memory options and their product numbers, and Table 1-30 lists the CompactFlash Disk memory options and their product numbers.

*Table 1-28 Flash Memory Card Options*

Memory Size	Product Number <sup>1</sup>
16 MB	MEM-I/O-FLC16M=
20 MB	MEM-I/O-FLC20M=

1. These products are also available as Flash memory card upgrades. To order an upgrade, add an equal sign (=) after the product number, for example, MEM-I/O-FLC16M=.

*Table 1-29 Flash Disk Memory Options*

Memory Size	Product Number <sup>1</sup>
32 MB	MEM-I/O-FLD32M=
48 MB	MEM-I/O-FLD48M=
64 MB	MEM-I/O-FLD64M=
128 MB	MEM-I/O-FLD128M=

1. These products are also available as Flash Disk upgrades. To order an upgrade, add an equal sign (=) after the product number, for example, MEM-I/O-FLD128M=.

*Table 1-30 NPE-G1 CompactFlash Disk Memory Options*

Memory Size	Product Number
64 MB	MEM-COMP-FLD64M=
128 MB	MEM-COMP-FLD128M=

## Rack-Mount and Cable-Management Kit

The rack-mount and cable-management kit for the Cisco 7200 VXR routers consists of rack-mount and cable-management brackets that are designed for mounting your router in 19-inch, four-post or 2-post equipment racks and for relieving strain on port adapter interface cables that are installed on port adapters in the router. The kit is shipped with each Cisco 7200 VXR router and is also available as a single FRU.

For detailed instructions about how to install the rack-mount and cable-management brackets on your Cisco 7200 VXR router, see [Chapter 3, “Installing a Cisco 7200 VXR Router,”](#) the “[Rack-Mounting a Cisco 7200 VXR Router](#)” section on page 3-2 and the “[General Tabletop or Workbench Installation](#)” section on page 3-14.

# Functional Overview

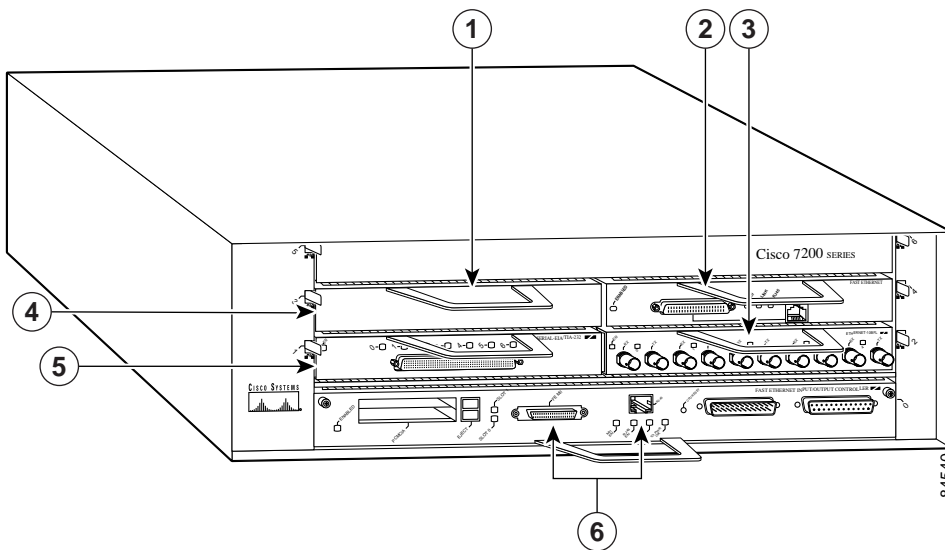
This section provides a functional overview of the Cisco 7200 VXR routers. It describes the numbering and addressing scheme of the port adapters for the router, the environmental monitoring and reporting functions, and online insertion and removal (OIR). These descriptions help you become familiar with the capabilities of the Cisco 7200 VXR routers.

## Chassis Slot and Logical Interface Numbering

In the Cisco 7200 VXR routers, the *port-adapter-slot-number* is the chassis slot in which a port adapter is installed, whereas the *logical-interface-number* is the physical location of the interface port on a port adapter.

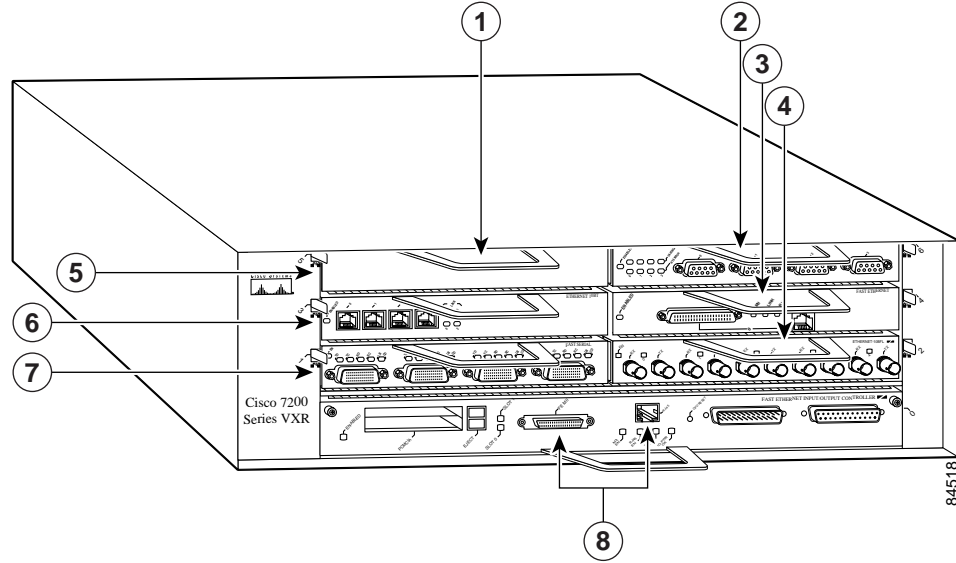
Port adapter slots in the Cisco 7200 VXR routers are numbered from left to right— slot 1 through slot 4 in the Cisco 7204VXR (see [Figure 1-29](#)) and slot 1 through slot 6 in the Cisco 7206VXR (see [Figure 1-30](#)). Port adapter slot 0 is always reserved for the Fast Ethernet port on the I/O controller—if present.

**Figure 1-29 Port Adapter Slot Numbering—Cisco 7204VXR**



1	Blank port adapter	4	Port adapter slot 3
2	Port adapter slot 4	5	Port adapter slot 1
3	Port adapter slot 2	6	Port adapter slot 0

Figure 1-30 Port Adapter Slot Numbering—Cisco 7206VXR



1	Blank port adapter	5	Port adapter slot 5
2	Port adapter slot 6	6	Port adapter slot 3
3	Port adapter slot 4	7	Port adapter slot 1
4	Port adapter slot 2	8	Port adapter slot 0

The Media Access Control (MAC) address or hardware address is a standardized data link layer address that is required for certain network interface types. These addresses are not used by other devices in the network; they are specific and unique to each port. The Cisco 7200 VXR routers use a specific method to assign and control the MAC addresses of its port adapters. For a description of the MAC address, see the “MAC Address” section on page 1-53.

Port adapter slots maintain the same slot number regardless of whether other port adapters are installed or removed. However, when you move a port adapter to a different slot, the port adapter slot number changes to reflect the new slot number.

You can identify port adapter slots by using software commands. To display information about all port adapter slots, use the **show interfaces** command. To display information about a specific port adapter slot, use the **show interfaces** command with the port adapter type and slot number in the format **show interfaces port-adapter-type slot-number/port-number**. If you abbreviate the command (**sh int**) and do not specify port adapter type and slot number (or arguments), the system interprets the command as **show interfaces** and displays the status of all port adapters and ports.

The following example shows how the show interfaces command, used without arguments, displays status information (including the physical port adapter number) for each port adapter in a Cisco 7206VXR.

In the following example, most of the status information for each interface is omitted.

```
Router#show interfaces
```

```
FastEthernet0/0 is administratively down, line protocol is down
  Hardware is i82543 (Livengood), address is 0000.0000.0000 (bia 0000.0000.0000)
  MTU 1500 bytes, BW 100000 Kbit, DLY 100 usec,
    reliability 255/255, txload 1/255, rxload 1/255
```

```
(display text omitted)
```

```

FastEthernet0/1 is administratively down, line protocol is down
  Hardware is i82543 (Livengood), address is 0000.0000.0000 (bia 0000.0000.0000)
  MTU 1500 bytes, BW 100000 Kbit, DLY 100 usec,
    reliability 255/255, txload 1/255, rxload 1/255

(display text omitted)

GigabitEthernet0/1 is up, line protocol is up
  Hardware is BCM-12500 Internal MAC, address is 0000.0000.0000 (bia 0000.0000.0000)
  Internet address is 00.00.00.00/00
  MTU 1500 bytes, BW 1000000 Kbit, DLY 10 usec,
    reliability 255/255, txload 2/255, rxload 2/255

(display text omitted)

GigabitEthernet0/2 is up, line protocol is up
  Hardware is BCM-12500 Internal MAC, address is 0000.0000.0000(bia 0000.0000.0000)
  Internet address is 00.00.00.00/00
  MTU 1500 bytes, BW 1000000 Kbit, DLY 10 usec,
    reliability 255/255, txload 2/255, rxload 2/255

(display text omitted)

GigabitEthernet0/3 is administratively down, line protocol is down
  Hardware is BCM-12500 Internal MAC, address is 0000.0000.0000 (bia 0000.0000.0000)
  Internet address is 00.00.00.00/00
  MTU 1500 bytes, BW 1000000 Kbit, DLY 10 usec,
    reliability 255/255, txload 1/255, rxload 1/255

(display text omitted)

FastEthernet2/0 is administratively down, line protocol is down
  Hardware is i82543 (Livengood), address is 0000.0000.0000 (bia 0000.0000.0000)
  MTU 1500 bytes, BW 100000 Kbit, DLY 100 usec,
    reliability 255/255, txload 1/255, rxload 1/255

(display text omitted)

FastEthernet2/1 is administratively down, line protocol is down
  Hardware is i82543 (Livengood), address is 0000.0000.0000 (bia 0000.0000.0000)
  MTU 1500 bytes, BW 100000 Kbit, DLY 100 usec,
    reliability 255/255, txload 1/255, rxload 1/255

(display text omitted)

FastEthernet5/0 is up, line protocol is up
  Hardware is DEC21140, address is 0000.0000.0000 (bia 0000.0000.0000)
  Internet address is 00.00.00.00/00
  MTU 1500 bytes, BW 100000 Kbit, DLY 100 usec,
    reliability 255/255, txload 1/255, rxload 1/255

```

You can also use arguments such as the interface type (Ethernet, Token Ring, ATM, and so forth) and the port address (*slot-number/port-number*) to display information about a specific interface only.

The following example shows the display for the first port on the Fast Ethernet port adapter in port adapter slot 3:

```

Router# show interface fastethernet 5/0

FastEthernet5/0 is up, line protocol is up
  Hardware is DEC21140, address is 0000.0000.0000 (bia 0000.0000.0000)
  Internet address is 0.0.0.0
  MTU 1500 bytes, BW 100000 Kbit, DLY 100 usec,

```

```
reliability 255/255, txload 1/255, rxload 1/255
Encapsulation ARPA, loopback not set
Keepalive not set
Full-duplex, 100Mb/s, 100BaseTX/FX
ARP type:ARPA, ARP Timeout 04:00:00
(display text omitted)
```

For complete descriptions and instructions of the commands used to configure your Cisco 7200 VXR router, refer to the *Configuration Fundamentals Configuration Guide* and *Configuration Fundamentals Command Reference* publications, which are available on Cisco.com, the Documentation CD-ROM, or in print.

## MAC Address

All LAN interfaces (ports) require unique MAC addresses, also known as *hardware* addresses. Typically, the MAC address of an interface is stored on a memory component that resides directly on the interface circuitry; however, the OIR feature requires a different method. (For a description of OIR, see the [“Online Insertion and Removal” section on page 1-53.](#))

Using OIR you can remove a port adapter and replace it with another identically configured one. If the new port adapter matches the port adapter you removed, the system immediately brings it online. In order to enable OIR, an address allocator with unique MAC addresses is stored in an EPROM on the router midplane. Each address is reserved for a specific port and slot in the router regardless of whether a port adapter resides in that slot. The MAC addresses are assigned to the slots in sequence. The first address is assigned to slot 0, and the last address is assigned to slot 4 in the Cisco 7204VXR or to slot 6 in the Cisco 7206VXR. Using this address scheme, you can remove port adapters and insert them into other routers without causing the MAC addresses to move around the network or be assigned to multiple devices.

Note that if the MAC addresses were stored on each port adapter, OIR would not function because you could never replace one port adapter with an identical one; the MAC addresses would always be different. Also, each time a port adapter was replaced, other devices on the network would have to update their data structures with the new address. If the other devices did not update quickly enough, the same MAC address could appear in more than one device at the same time.



---

**Note**

Storing the MAC addresses for every slot in one central location means the addresses stay with the memory device on which they are stored.

---

## Online Insertion and Removal

All port adapters and service adapters in the Cisco 7200 VXR routers support online insertion and removal (OIR). However, it is wise to shut down the interface before removing a port adapter that has active traffic moving through it. Removing a port adapter while traffic is flowing through the ports can cause system disruption. Once the port adapter is inserted, the ports can be brought back up.



---

**Note**

As you disengage the port adapter from the router or switch, online insertion and removal (OIR) administratively shuts down all active interfaces in the port adapter.

---

OIR allows you to install and replace port adapters and service adapters while the router is operating; you do not need to notify the software or shut down the system power, although you should not run traffic through the port adapter you are removing while it is being removed. OIR is a method that is seamless to end users on the network, maintains all routing information, and preserves sessions.

The following is a functional description of OIR for background information only; for specific procedures for installing and replacing a port adapter or service adapter in a Cisco 7200 VXR router, refer to the online configuration note for each port adapter or service adapter.

**Caution**

---

The network processing engine or network services engine and the I/O controller are required system components that cannot be removed if the router is operating. Removing the network processing engine or network services engine or the I/O controller while the router is operating causes the router to shut down or crash and might damage or destroy memory files.

---

Each port adapter or service adapter has a bus connector that connects it to the router midplane. Each midplane connector has a set of tiered pins in three lengths that send specific signals to the system as they make contact with the port adapter or service adapter. The system assesses the signals it receives and the order in which it receives them to determine if a port adapter or service adapter is being removed or inserted into the midplane. From these signals, the system determines whether to reinitialize a new interface or shut down a removed interface. For example, when you insert a port adapter or service adapter, the longest pins make contact with the port adapter or service adapter first, and the shortest pins make contact last. The system recognizes the signals and the sequence in which it receives them.

When you remove or insert a port adapter or service adapter in a Cisco 7200 VXR router, the midplane pins send signals to notify the system, which then performs as follows:

1. Rapidly scans the midplane for configuration changes.
2. Initializes all newly inserted port adapter or service adapters, noting any removed interfaces and placing them in the administratively shutdown state.
3. Brings all previously configured interfaces on the port adapter back to the state they were in when they were removed. Any newly inserted interfaces are put in the administratively shutdown state, as if they were present (but not configured) at boot time. If a similar port adapter type is reinserted into a slot, its ports are configured and brought online up to the port count of the original port adapter. (A service adapter has no configurable ports.)

## Environmental Monitoring and Reporting Functions

Environmental monitoring and reporting functions are controlled by the network processing engine or network services engine and allow you to maintain normal system operation by identifying and resolving adverse conditions prior to loss of operation. The environmental monitoring functions constantly monitor the internal chassis air temperature and DC supply voltages and currents. Each power supply monitors its own voltage and temperature and shuts itself down if it detects a critical condition within the power supply. If conditions reach shutdown, the system shuts down to avoid equipment damage from excessive heat. The reporting functions periodically log the values of measured parameters so that you can retrieve them for analysis later, and the reporting functions display warnings on the console if any of the monitored parameters exceed defined thresholds.

## Environmental Monitoring

The environmental monitoring functions use four sensors, two on the network processing engine or network services engine and two on the I/O controller, to monitor the temperature of the cooling air as it moves through the chassis.

If the air temperature exceeds a defined threshold, the system controller displays warning messages on the console terminal, and if the temperature exceeds the shutdown threshold, the system controller shuts down the system. The system stores the present parameter measurements for both temperature and DC voltage in NVRAM so you can retrieve them later as a report of the last shutdown parameters.

In addition, the power supplies monitor internal power supply temperature and voltages. A power supply is either within tolerance (normal) or out of tolerance (critical). If an internal power supply temperature or voltage reaches a critical level, the power supply shuts down without any interaction with the system processor.

The environmental monitoring functions use the following levels of status conditions to monitor the system:

- Normal—All monitored parameters are within normal tolerances.
- Warning—The system has exceeded a specified threshold. The system continues to operate, but operator action is recommended to bring the system back to a normal state.
- Critical—An out-of-tolerance temperature or voltage condition exists. The system continues to operate; however, the system is approaching shutdown. Immediate operator action is required.
- Shutdown—The processor has detected a temperature condition that could result in physical damage to system components and has disabled DC power to all internal components. This condition requires immediate operator action. All DC power remains disabled until you toggle the power switch. Before any shutdown, the system logs the status of monitored parameters in NVRAM so you can retrieve it later to help determine the cause of the problem.
- Power supply shutdown—The power supply detected an internal out-of-tolerance overvoltage, overcurrent, or temperature condition and shut itself down. All DC power remains disabled until you toggle the power switch.

[Table 1-31](#) lists the typical temperature thresholds for each network processing engine type, and [Table 1-32](#) lists the DC power thresholds for the normal, warning, and critical (power supply-monitored) levels.

**Table 1-31 Typical Processor-Monitored Temperature Thresholds**

Parameter	High Warning	High Critical	Shutdown
<b>NPE-175, NPE-225, NPE-300, NPE-400, NSE-1, NPE-G1</b>			
Chassis inlet	104 F (40 C)	122 F (50 C)	—
Chassis outlet 1	109 F (43 C)	127 F (53 C)	136 F (58 C)
Chassis outlet 2	109 F (43 C)	127 F (53 C)	—
Chassis outlet 3	131 F (55 C)	149 F (65 C)	158 F (70 C)
<b>NPE-100 or NPE-200</b>			
Chassis inlet	104 F (40 C)	122 F (50 C)	—
Chassis outlet 1	109 F (43 C)	127 F (53 C)	136 F (58 C)
Chassis outlet 2	167 F (75 C)	167 F (75 C)	—

*Table 1-31 Typical Processor-Monitored Temperature Thresholds (continued)*

Parameter	High Warning	High Critical	Shutdown
Chassis outlet 3	122 F (50 C)	140 F (60 C)	149 F (65 C)
<b>NPE-150</b>			
Chassis inlet	104 F (40 C)	122 F (50 C)	—
Chassis outlet 1	109 F (43 C)	127 F (53 C)	136 F (58 C)
Chassis outlet 2	167 F (75 C)	167 F (75 C)	—
Chassis outlet 3	131 F (55 C)	149 F (65 C)	158 F (70 C)

*Table 1-32 Typical Power Supply-Monitored DC-Voltage Thresholds*

Parameter	Low Critical	Low Warning	High Warning	High Critical
+3.45V	+3.26V	+3.34V	+3.55V	+3.63V
+5.15V	+4.86V	+4.99V	+5.31V	+5.43V
+12.15V	+11.39V	+11.67	+12.62V	+12.91V
-11.95V	-9.52V	-10.73	-13.16V	-14.38V

## Reporting Functions

The Cisco 7200 VXR routers display warning messages on the console if chassis interface-monitored parameters exceed a desired threshold. You can also retrieve and display environmental status reports with the **show environment**, **show environment all**, **show environment last**, and **show environment table** commands. Parameters are measured and reporting functions are updated every 60 seconds. A brief description of each of these commands follows.



### Caution

To prevent overheating the chassis, ensure that your system is drawing cool inlet air. Overtemperature conditions can occur if the system is drawing in the exhaust air of other equipment. Ensure adequate clearance around the sides of the chassis so that cooling air can flow through the chassis interior unimpeded and exhaust air exits the chassis and is not drawn into the inlet vent of another device.

The **show environment** command displays reports of the current environmental system status. The report displays parameters that are out of the normal values. No parameters are displayed if the system status is normal. The example that follows shows the display for a system in which all monitored parameters are within normal range:

```
Router# show environment
```

```
All measured values are normal
```

If the environmental status is *not* normal, the system reports the worst-case status level. Following is a sample overvoltage warning:

```
Router# show environment
```

```
Warning: +3.45 V measured at +3.83 V
```



The **show environment last** command retrieves and displays the NVRAM log, which shows the reason for the last system shutdown (if the shutdown was related to voltage or temperature) and the environmental status at that time. Air temperature is measured and displayed, and the DC voltage supplied by the power supply is also displayed.

Following is sample output of the **show environment last** command:

```
NPE300(boot)# show environment last
chassis inlet           previously measured at 26C/78F
  chassis outlet 1     previously measured at 28C/82F
  chassis outlet 2     previously measured at 29C/84F
  chassis outlet 3     previously measured at 33C/91F
+3.45 V                 previously measured at +3.46
+5.15 V                 previously measured at +5.23
+12.15 V                previously measured at +12.24
-11.95 V                previously measured at -11.81
last shutdown reason - power supply shutdown
```

The **show environment table** command displays the temperature and voltage thresholds for each temperature sensor and for each monitored status level. These thresholds are related to those listed in [Table 1-31](#) and [Table 1-32](#). The display also lists the shutdown threshold for the system.

Following is sample output of the **show environment table** command for a Cisco 7206VXR that has an installed NPE-300:

```
NPE300(boot)# show environment table

Sample Point           LowCritical      LowWarning      HighWarning      HighCritical
chassis inlet          40C/104F        50C/122F
chassis outlet 1      43C/109F        53C/127F
chassis outlet 2      75C/167F        75C/167F
chassis outlet 3      50C/122F        60C/140F
+3.45 V                +3.26           +3.34           +3.55            +3.63
+5.15 V                +4.86           +4.99           +5.31            +5.43
+12.15 V               +11.39          +11.67          +12.62           +12.91
-11.95 V               -9.52           -10.73          -13.16           -14.38
```

```
System shutdown for chassis inlet is 75C/167F
System shutdown for chassis outlet 1 is 58C/136F
System shutdown for chassis outlet 2 is 75C/167F
System shutdown for chassis outlet 3 is 65C/149F
```



#### Note

Temperature ranges and values are subject to change.

The **show environment all** command displays an extended report that includes temperature readings and voltage readings. The **show environment all** command also displays a report showing which power supply slots are occupied and which are empty.

Following is sample output of the **show environment all** command:

```
NPE300(boot)# show environment all

Power Supplies:
  Power Supply 1 is empty.
  Power Supply 2 is ZyteK AC Power Supply. Unit is on.

Temperature readings:
  chassis inlet     measured at 26C/78F
  chassis outlet 1  measured at 28C/82F
```

```
chassis outlet 2 measured at 29C/84F
chassis outlet 3 measured at 33C/91F
```

Voltage readings:

```
+3.45 V      measured at +3.46 V
+5.15 V      measured at +5.25 V
+12.15 V     measured at +12.24 V
-11.95 V     measured at -11.81 V
```

```
EnvM stats saved 138 time(s) since reload
```

## Fan Failures

When the system power is on, all three fans should be operational. The system continues to operate if a fan fails; however, if the air temperature exceeds a defined threshold, the system controller displays warning messages on the console terminal, and if the temperature exceeds the shutdown threshold, the system controller shuts down the system.

If the system does shut down because the temperature exceeded the shutdown threshold, the system displays the following message on the console screen and in the environment display when the system restarts:

```
Queued messages:
%ENVM-1-SHUTDOWN: Environmental Monitor initiated shutdown
```

For complete descriptions and instructions for the environmental monitor commands, refer to the *Configuration Fundamentals Configuration Guide* and *Configuration Fundamentals Command Reference* publications, which are available on Cisco.com, the Documentation CD-ROM, or in print.