

AFBR-57J5APZ

Digital Diagnostic SFP, 850nm 3.072/2.4576 Gb/s,
RoHS OBSAI/CPRI Compatible Optical Transceiver



Data Sheet



Description

Avago's AFBR-57J5APZ optical transceiver supports high speed serial links over multimode optical fiber at signaling rates up to 3.7Gb/s for wireless base station applications involving the OBSAI or CPRI protocols, as well as related applications. The transceiver is compliant with Small Form Pluggable (SFP) multi-source agreements INF-8074 and SFF-8472 for mechanical and electrical specifications and FOCIS/IEC specifications for optical duplex LC connectors.

As an enhancement to the conventional SFP interfaced defined in INF-8074, the AFBR-57J5APZ is compliant to SFF-8472 (Digital Diagnostic Interface for Optical Transceivers). Using the 2-wire serial interface defined in SFF-8472, the transceiver provides real time temperature, supply voltage, laser bias current, laser average output power and received input power. This information is in addition to conventional SFP base data. The digital diagnostic interface also adds the ability to disable the transmitter and monitor the status of transmitter fault and receiver loss of signal.

Related Products

- AFBR-57R5AEZ: 850nm +3.3V LC SFP for 4.25/2.125/1.0625 GBd Fibre Channel
- AFCT-57J5APZ: 1310nm +3.3V LC SFP for CPRI/OBSAI Applications
- AFCT-57J5ATPZ: 1310nm +3.3V LC SFP for CPRI/OBSAI Applications
- AFBR-57D7APZ: 850nm +3.3V LC SFP for 8.5/4.25/2.125 GBd Fibre Channel
- AFCT-57D5ATPZ: 1310nm +3.3V LC SFP for 8.5/4.25/2.125 GBd Fibre Channel

Features

- Fully RoHS Compliant
- Diagnostic Features Per SFF-8472 "Diagnostic Monitoring Interface for Optical Transceivers"
- Real time monitors of:
 - o Transmitted Optical Power
 - o Received Optical Power
 - o Laser Bias Current
 - o Temperature
 - o Supply Voltage
- Industrial Temperature and Supply Voltage Operation (-40°C to 85°C) (3.3V ± 10%)
- Transceiver Specifications per SFP (INF-8074) and SFF-8472 (revision 9.6)
- Up to 300m with 50µm OM3 for 3.7 Gb/s
- Up to 400m with 50µm OM3 for OBSAI 3.072 Gb/s
- Up to 500m with 50µm OM3 for CPRI 2.457 Gb/s
- LC Duplex optical connector interface conforming to ANSI TIA/EIA604-10 (FOCIS 10A)
- 850nm Vertical Cavity Surface Emitting Laser (VCSEL) Source Technology
- IEC 60825-1 Class 1/CDRH Class 1 laser eye safe
- Compatible with Fibre Channel and Gigabit Ethernet applications

Applications

Wireless and cellular base station system interconnect

OBSAI rates 3.072 Gb/s, 1.536 Gb/s, 0.768 Gb/s

CPRI rates 2.4576 Gb/s, 1.2288 Gb/s, 0.6144 Gb/s

Digital Diagnostic Interface and Serial Identification

The 2-wire serial interface is based on ATMEL AT24C01A series EEPROM protocol and signaling detail. Conventional EEPROM memory, bytes 0-255 at memory address 0xA0, is organized in compliance with INF-8074. New digital diagnostic information, bytes 0-255 at memory address 0xA2, is compliant to SFF-8472. The new diagnostic information provides the opportunity for Predictive Failure Identification, Compliance Prediction, Fault Isolation and Component Monitoring.

The I2C accessible memory page address 0xB0 is used internally by SFP for the test and diagnostic purposes and it is reserved.

Transmitter Section

The transmitter section includes consists of the Transmitter Optical SubAssembly (TOSA) and laser driver circuitry. The TOSA, containing an 850nm VCSEL (Vertical Cavity Surface Emitting Laser) light source, is located at the optical interface and mates with the LC optical connector. The TOSA is driven by a custom IC which uses the incoming differential high speed logic signal to modulate the laser diode driver current. This Tx laser driver circuit regulates the optical power at a constant level provided the incoming data pattern is dc balanced (8B/10B code, for example).

Transmit Disable (Tx_Disable)

The AFBR-57J5APZ accepts a TTL and CMOS compatible transmit disable control signal input (pin 3) which shuts down the transmitter optical output. A high signal implements this function while a low signal allows normal transceiver operation. In the event of a fault (e.g. eye safety circuit activated), cycling this control signal resets the module as depicted in Figure 4. An internal pull up resistor disables the transceiver transmitter until the host pulls the input low. Host systems should allow a 10ms interval between successive assertions of this

control signal. Tx_Disable can also be asserted via the two-wire serial interface (address A2h, byte 110, bit 6) and monitored (address A2h, byte 110, bit 7).

The contents of A2h, byte 110, bit 6 are logic OR'd with hardware Tx_Disable (pin 3) to control transmitter operation..

Transmit Fault (Tx_Fault)

A catastrophic laser fault will activate the transmitter signal, TX_FAULT, and disable the laser. This signal is an open collector output (pull-up required on the host board). A low signal indicates normal laser operation and a high signal indicates a fault. The TX_FAULT will be latched high when a laser fault occurs and is cleared by toggling the TX_DISABLE input or power cycling the transceiver. The transmitter fault condition can also be monitored via the two-wire serial interface (address A2, byte 110, bit 2).

Eye Safety Circuit

The AFBR-57J5APZ provides Class 1 (single fault tolerant) eye safety by design and has been tested for compliance with the requirements listed in Table 1. The eye safety circuit continuously monitors the optical output power level and will disable the transmitter upon detecting an unsafe condition beyond the scope of Class 1 certification. Such unsafe conditions can be due to inputs from the host board (Vcc fluctuation, unbalanced code) or a fault within the transceiver.

Receiver Section

The receiver section includes the Receiver Optical SubAssembly (ROSA) and the amplification/quantization circuitry. The ROSA, containing a PIN photodiode and custom transimpedance amplifier, is located at the optical interface and mates with the LC optical connector. The ROSA output is fed to a custom IC that provides post-amplification and quantization.

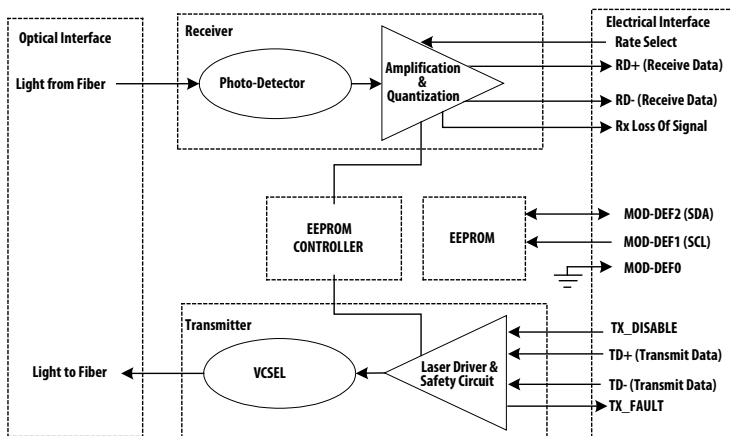

Figure 1. Transceiver Functional Diagram

Receiver Loss of Signal (Rx_LOS)

The post-amplification IC also includes transition detection circuitry which monitors the ac level of incoming optical signals and provides a TTL/CMOS compatible status signal to the host (pin 8). An adequate optical input results in a low Rx_LOS output while a high Rx_LOS output indicates an unusable optical input. The Rx_LOS thresholds are factory set so that a high output indicates a definite optical fault has occurred. Rx_LOS can also be monitored via the two-wire serial interface (address A2h, byte 110, bit 1).

Functional Data I/O

The AFBR-57J5APZ interfaces with the host circuit board through twenty I/O pins (SFP electrical connector) identified by function in Table 2. The board layout for this interface is depicted in Figure 6.

The AFBR-57J5APZ high speed transmit and receive interfaces require SFP MSA, OBSAI or CPRI compliant signal lines on the host board. To simplify board requirements, biasing resistors and ac coupling capacitors are incorporated into the SFP transceiver module (per INF-8074) and hence are not required on the host board. The Tx_Disable, Tx_Fault, Rx_LOS and Rate_Select lines require TTL lines on the host board (per INF-8074) if used. If an application chooses not to take advantage of the functionality of these pins care must be taken to ground Tx_Disable (for normal operation) and Rate_Select is set to default in the proper state.

Figure 2 depicts the recommended interface circuit to link the AFBR-57J5APZ to supporting physical layer ICs. Timing for MSA compliant control signals implemented in the transceiver are listed in Figure 4.

Application Support

An Evaluation Kit and Reference Designs are available to assist in evaluation of the AFBR-57J5APZ. Please contact your local Field Sales representative for availability and ordering details.

Caution

There are no user serviceable parts nor maintenance requirements for the AFBR-57J5APZ. All mechanical adjustments are made at the factory prior to shipment. Tampering with, modifying, misusing or improperly handling the AFBR-57J5APZ will void the product warranty. It may also result in improper operation and possibly overstress the laser source. Performance degradation or device failure may result. Connection of the AFBR-57J5APZ to a light source not compliant with these specifications, operating above maximum operating conditions or in a manner inconsistent with its design and function may result in exposure to hazardous light radiation and may constitute an act of modifying or man-

ufacturing a laser product. Persons performing such an act are required by law to re-certify and re-identify the laser product under the provisions of U.S. 21 CFR (Subchapter J) and TUV.

Ordering Information

Please contact your local field sales engineer or one of Avago Technologies franchised distributors for ordering information. For technical information, please visit Avago Technologies' WEB page at www.Avago.com or contact Avago Technologies Semiconductor Products Customer Response Center at 1-800-235-0312. For information related to SFF Committee documentation visit www.sffcommittee.org.

Regulatory Compliance

The AFBR-57J5APZ complies with all applicable laws and regulations as detailed in Table 1. Certification level is dependent on the overall configuration of the host equipment. The transceiver performance is offered as a figure of merit to assist the designer

Electrostatic Discharge (ESD)

The AFBR-57J5APZ is compatible with ESD levels found in typical manufacturing and operating environments as described in Table 1. In the normal handling and operation of optical transceivers, ESD is of concern in two circumstances.

The first case is during handling of the transceiver prior to insertion into an SFP compliant cage. To protect the device, it's important to use normal ESD handling precautions. These include using of grounded wrist straps, workbenches and floor wherever a transceiver is handled.

The second case to consider is static discharges to the exterior of the host equipment chassis after installation. If the optical interface is exposed to the exterior of host equipment cabinet, the transceiver may be subject to system level ESD requirements.

Electromagnetic Interference (EMI)

Equipment incorporating gigabit transceivers is typically subject to regulation by the FCC in the United States, CENELEC EN55022 (CISPR 22) in Europe and VCCI in Japan. The AFBR-57J5APZ's compliance to these standards is detailed in Table 1. The metal housing and shielded design of the AFBR-57J5APZ minimizes the EMI challenge facing the equipment designer.

EMI Immunity (Susceptibility)

Due to its shielded design, the EMI immunity of the AFBR-57J5APZ exceeds typical industry standards.

Flammability

The AFBR-57J5APZ optical transceiver is made of metal and high strength, heat resistant, chemical resistant and UL 94V-0 flame retardant plastic.

Predictive Failure Identification

The AFBR-57J5APZ predictive failure feature allows a host to identify potential link problems before system performance is impacted. Prior identification of link problems enables a host to service an application via “fail over” to a redundant link or replace a suspect device, maintaining system uptime in the process. For applications where ultra-high system uptime is required, a digital SFP provides a means to monitor two real-time laser metrics associated with observing laser degradation and predicting failure: average laser bias current (Tx_Bias) and average laser optical power (Tx_Power).

Compliance Prediction:

Compliance prediction is the ability to determine if an optical transceiver is operating within its operating and environmental requirements. AFBR-57J5APZ devices provide real-time access to transceiver internal supply voltage and temperature, allowing a host to identify potential component compliance issues. Received optical power is also available to assess compliance of a cable

plant and remote transmitter. When operating out of requirements, the link cannot guarantee error free transmission.

Fault Isolation

The fault isolation feature allows a host to quickly pinpoint the location of a link failure, minimizing downtime. For optical links, the ability to identify a fault at a local device, remote device or cable plant is crucial to speeding service of an installation. AFBR-57J5APZ real-time monitors of Tx_Bias, Tx_Power, Vcc, Temperature and Rx_Power can be used to assess local transceiver current operating conditions. In addition, status flags Tx_Disable and Rx Loss of Signal (LOS) are mirrored in memory and available via the two-wire serial interface.

Component Monitoring

Component evaluation is a more casual use of the AFBR-57J5APZ real-time monitors of Tx_Bias, Tx_Power, Vcc, Temperature and Rx_Power. Potential uses are as debugging aids for system installation and design, and transceiver parametric evaluation for factory or field qualification. For example, temperature per module can be observed in high density applications to facilitate thermal evaluation of blades, PCI cards and systems.

Table 1. Regulatory Compliance

Feature	Test Method	Performance
Electrostatic Discharge (ESD) to the Electrical Pins	MIL-STD-883C Method 3015.4	Class 1 (> 2000 Volts)
Electrostatic Discharge (ESD) to the Duplex LC Receptacle	Variation of IEC 61000-4-2 GR1089	Typically, no damage occurs with 25 kV when the duplex LC connector receptacle is contacted by a Human Body Model probe. 10 contacts of 8 kV on the electrical faceplate with device inserted into a panel.
Electrostatic Discharge (ESD) to the Optical Connector	Variation of IEC 801-2	Air discharge of 15kV(min) contact to connector w/o damage
Electromagnetic Interference (EMI)	FCC Class B CENELEC EN55022 Class B (CISPR 22A) VCCI Class 1	System margins are dependent on customer board and chassis design.
Immunity	Variation of IEC 61000-4-3	Typically shows no measurable effect from a 10V/m field swept from 10 MHz to 1 GHz.
Laser Eye Safety and Equipment Type Testing	US FDA CDRH AEL Class 1 US21 CFR, Subchapter J per Paragraphs 1002.10 and 1002.12. (IEC) EN60825-1: 1994 + A11+A2 (IEC) EN60825-2: 1994 + A1 (IEC) EN60950: 1992 + A1 + A2 + A3+ A4 + A11	CDRH certification # 9720151-083 TUV file # 72060710
Component Recognition	Underwriters Laboratories and Canadian Standards Association Joint Component Recognition for Information Technology Equipment Including Electrical Business Equipment	UL File # E173874

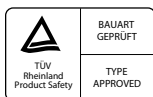

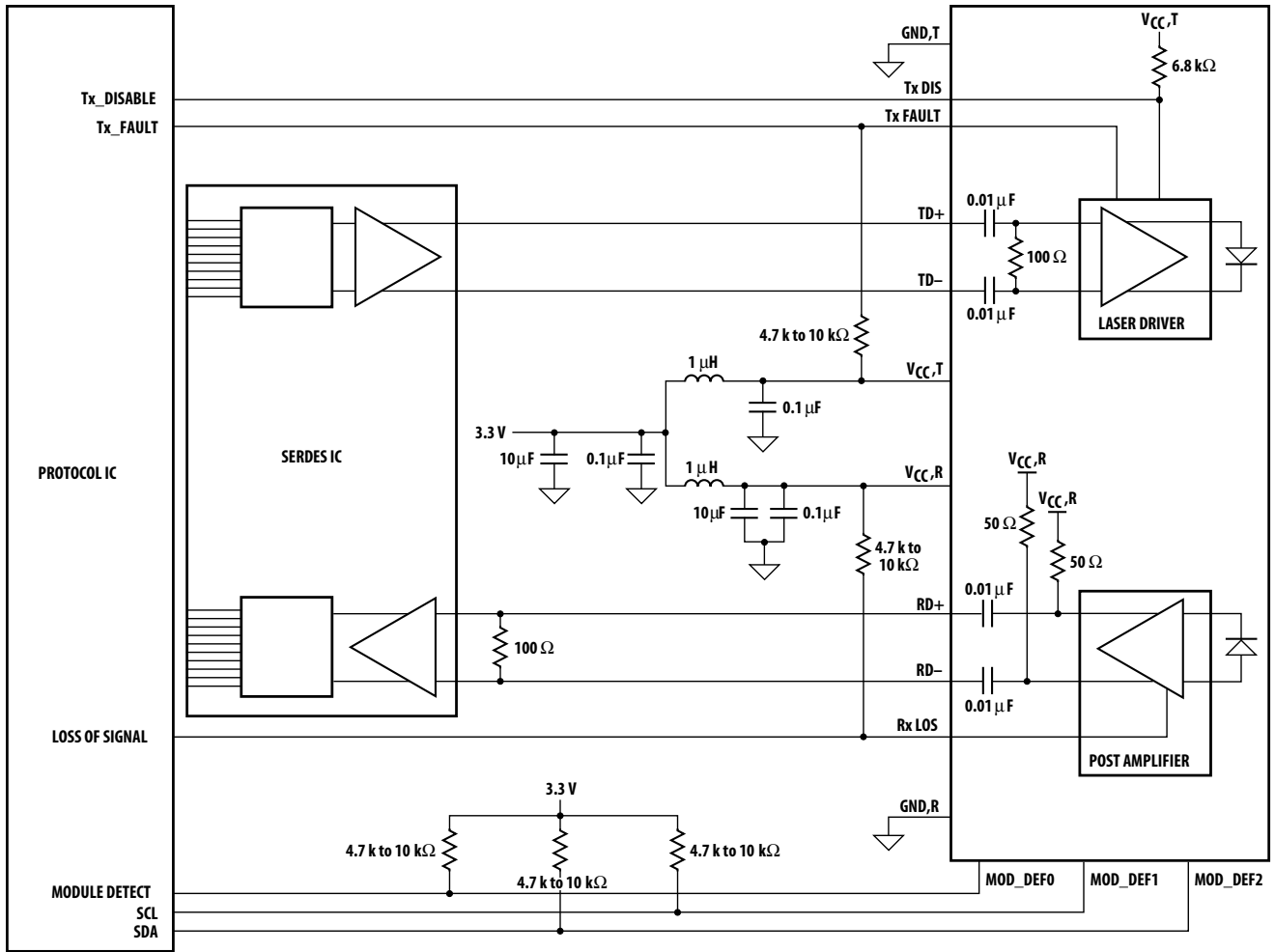
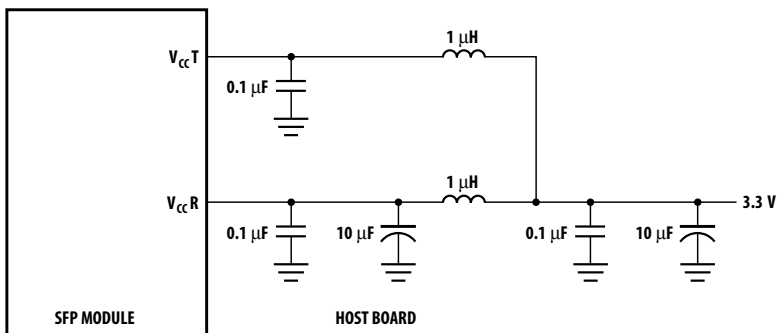

Figure 2. Typical Application Configuration



NOTE: INDUCTORS MUST HAVE LESS THAN 1 Ω SERIES RESISTANCE TO LIMIT VOLTAGE DROP TO THE SFP MODULE.

Figure 3. Recommended Power Supply Filter

Table 2. Pin Description

Pin	Name	Function/Description	Notes
1	VeeT	Transmitter Ground	
2	TX_FAULT	Transmitter Fault Indication – High indicates a fault condition	Note 1
3	TX_DISABLE	Transmitter Disable – Module optical output disables on high or open	Note 2
4	MOD-DEF2	Module Definition 2 – Two wire serial ID interface data line (SDA)	Note 3
5	MOD-DEF1	Module Definition 1 – Two wire serial ID interface clock line (SCL)	Note 3
6	MOD-DEF0	Module Definition 0 – Grounded in module (module present indicator)	Note 3
7	no connect		
8	RX_LOS	Loss of Signal – High indicates loss of received optical signal	Note 4
9	VeeR	Receiver Ground	
10	VeeR	Receiver Ground	
11	VeeR	Receiver Ground	
12	RD-	Inverse Received Data Out	Note 5
13	RD+	Received Data Out	Note 5
14	VeeR	Receiver Ground	
15	VccR	Receiver Power + 3.3 V	Note 6
16	VccT	Transmitter Power + 3.3 V	Note 6
17	VeeT	Transmitter Ground	
18	TD+	Transmitter Data In	Note 7
19	TD-	Inverse Transmitter Data In	Note 7
20	VeeT	Transmitter Ground	

Notes:

- TX_FAULT is an open collector/drain output, which must be pulled up with a 4.7k – 10kΩ resistor on the host board. When high, this output indicates a laser fault of some kind. Low indicates normal operation. In the low state, the output will be pulled to < 0.8V.
- TX_DISABLE is an input that is used to shut down the transmitter optical output. It is internally pulled up (within the transceiver) with a 6.8kΩ resistor.

Low (0 – 0.8V):	Transmitter on
Between (0.8V and 2.0V):	Undefined
High (2.0 – Vcc max) or OPEN:	Transmitter Disabled
- The signals Mod-Def 0, 1, 2 designate the two wire serial interface pins. They must be pulled up with a 4.7k – 10kΩ resistor on the host board.
Mod-Def 0 is grounded by the module to indicate the module is present
Mod-Def 1 is serial clock line (SCL) of two wire serial interface
Mod-Def 2 is serial data line (SDA) of two wire serial interface
- RX_LOS (Rx Loss of Signal) is an open collector/drain output that must be pulled up with a 4.7k – 10kΩ resistor on the host board. When high, this output indicates the received optical power is below the worst case receiver sensitivity (as defined by the standard in use). Low indicates normal operation. In the low state, the output will be pulled to < 0.8V.
- RD-/+ designate the differential receiver outputs. They are AC coupled 100Ω differential lines which should be terminated with 100Ω differential at the host SERDES input. AC coupling is done inside the transceiver and is not required on the host board. The voltage swing on these lines will be between 500 and 1600 mV differential (250 – 800 mV single ended) when properly terminated.
- VccR and VccT are the receiver and transmitter power supplies. They are defined at the SFP connector pin. The maximum supply current is 300 mA and the associated in-rush current will typically be no more than 30 mA above steady state after 500 nanoseconds.
- TD-/+ designate the differential transmitter inputs. They are AC coupled differential lines with 100Ω differential termination inside the module. The AC coupling is done inside the module and is not required on the host board. The inputs will accept differential swings of 400 – 2400 mV (200 – 1200 mV single ended), though it is recommended that values between 500 and 1200 mV differential (250 – 600 mV single ended) be used for best EMI performance.

Table 3. Absolute Maximum Ratings

Parameter	Symbol	Minimum	Maximum	Unit	Notes
Storage Temperature	T _S	-40	100	°C	Note 1,2
Case Operating Temperature	T _C	-40	100	°C	Note 1,2
Relative Humidity	RH	5	95	%	Note 1
Supply Voltage	V _{CC,T,R}	-0.5	3.8	V	Note 1,2,3
Low Speed Input Voltage	V _{IN}	-0.5	V _{CC} +0.5	V	Note 1

Notes

1. Absolute Maximum Ratings are those values beyond which damage to the device may occur if these limits are exceeded for other than a short period of time. See Reliability Data Sheet for specific reliability performance.
2. Between Absolute Maximum Ratings and the Recommended Operating Conditions functional performance is not intended, device reliability is not implied, and damage to the device may occur over an extended period of time.
3. The module supply voltages, V_{CC,T} and V_{CC,R} must not differ by more than 0.5V or damage to the device may occur.

Table 4. Recommended Operating Conditions

Parameter	Symbol	Minimum	Maximum	Unit	Notes
Case Operating Temperature	T _C	-40	85	°C	Note 1,2
Supply Voltage	V _{CC,T,R}	2.97	3.63	V	Note 2
Data Rate		0.614	3.072	Gb/s	Note 2

Notes

1. The Ambient Operating Temperature limitations are based on the Case Operating Temperature limitations and are subject to the host system thermal design.
2. Recommended Operating Conditions are those values for which functional performance and device reliability is implied.

Table 5. Transceiver Electrical Characteristics (T_C = -40°C to 85°C, V_{CC,T}, V_{CC,R} = 3.3V ± 10%)

Parameter	Symbol	Minimum	Typical	Maximum	Unit	Notes
AC Electrical Characteristics						
Power Supply Noise Rejection (peak-peak)	PSNR	100			mV	Note 1
DC Electrical Characteristics						
Module supply current	I _{CC}			300	mA	
Power Dissipation	P _{DISS}			1.0	W	
Low Speed Outputs: Transmit Fault (TX_FAULT), Loss of Signal (RX_LOS), MOD-DEF 2	V _{OH}	2.0		V _{CC,T,R} +0.3	V	Note 2
	V _{OL}			0.8	V	
Low Speed Inputs: Transmit Disable (TX_DIS), MOD-DEF 1, MOD-DEF 2	V _{IH}	2.0		V _{CC}	V	Note 3
	V _{IL}	0		0.8	V	

Notes:

1. Filter per SFP specification is required on host board to remove 10 Hz to 2 MHz content.
2. Pulled up externally with a 4.7k – 10kΩ resistor on the host board to 3.3V.
3. Mod-Def1 and Mod-Def2 must be pulled up externally with a 4.7k – 10kΩ resistor on the host board to 3.3V.

Table 6. Transmitter Optical Characteristics (TC = -40°C to 85°C, VccT, VccR = 3.3V ± 10%)

Parameter	Symbol	Minimum	Typical	Maximum	Unit	Notes
Modulated Optical Output Power (OMA) (Peak-to-Peak)	Tx,OMA	247			μW	Note 2
Average Optical Output Power	Pout	-9.0			dBm	Note 1, 2
Center Wavelength	λ _C	830		860	nm	
Spectral Width – rms	σ,rms			0.85	nm	
Optical Rise/Fall Time	tr, tf			100	ps	20% - 80%
RIN 12 (OMA)	RIN			-118	dB/Hz	
Transmitter Contributed Deterministic Jitter (0.614 to 3.072 Gb/s)	DJ			50	ps	-40/85°C, Note 3
				30	ps	-20/85°C, Note 3
Transmitter Contributed Total Jitter (0.614 to 3.072 Gb/s)	TJ			80	ps	-40/85°C, Note 4, 5
				60		-20/85°C, Note 4, 5
Pout TX_DISABLE Asserted	P _{OFF}			-35	dBm	

Notes:

1. Max Pout is the lesser of Class 1 safety limits (CDRH and EN 60825) or receiver power, max.
2. Into 50/125um (0.2 NA) multi-mode optical fiber.
3. Contributed DJ is measured on an oscilloscope in average mode with 50% threshold and K28.5 pattern.
4. Contributed RJ is calculated for 1x10⁻¹² BER by multiplying the RMS jitter (measured on a single rise or fall edge) from the oscilloscope by 14.
5. In a network link, each component's output jitter equals each component's input jitter combined with each component's contributed jitter. Contributed DJ adds in a linear fashion and contributed RJ adds in a RMS fashion.

Table 7. Receiver Optical Characteristics (TC = -40°C to 85°C, VccT, VccR = 3.3V ± 10%)

Parameter	Symbol	Min	Typ	Max	Unit	Notes
Input Optical Power [Overdrive]	P _{IN}			0	dBm, avg	
Input Optical Modulation Amplitude Peak-to-Peak (0.614 to 3.072 Gb/s) [Sensitivity]	OMA	61			μW, oma	1x10 ⁻¹² BER , Note 1
		85			μW, oma	1x10 ⁻¹⁵ BER, Note 1
Return Loss		12			dB	
Loss of Signal – Assert	P _A			27.5	uW, oma	
				-30	-17.5	dBm, avg
Loss of Signal - De-Assert	P _D			31	uW, oma	
				-17.0	dBm, avg	Note 2
Loss of Signal Hysteresis	P _D - P _A	0.5			dB	

Notes

1. Input Optical Modulation Amplitude (commonly known as sensitivity) requires a valid 8B/10B encoded input.
2. These average power values are specified with an Extinction Ratio of 9dB. The loss of signal circuitry responds to valid 8B/10B encoded peak to peak input optical power, not average power.

Table 8. Transmitter and Receiver Electrical Characteristics (TC = -40°C to 85°C, VccT, VccR = 3.3V ± 10%)

Parameter	Symbol	Minimum	Typical	Maximum	Unit	Notes
High Speed Data Input: Transmitter Differential Input Voltage (TD +/-)	V _I	400		2400	mV	Note 1
High Speed Data Output: Receiver Differential Output Voltage (RD +/-)	V _O	500		1600	mV	Note 2
Receiver Contributed Deterministic Jitter (0.614 to 3.072 Gb/s)	DJ			25	ps	Note 3, 7
Receiver Contributed Total Jitter (0.614 to 3.072 Gb/s)	TJ			65	ps	Note 4, 6, 7
Receiver Electrical Output Rise & Fall Times (20-80%)	Tr, tf	30		200	ps	Note 5

Notes

1. Internally AC coupled and terminated (100 Ohm differential).
2. Internally AC coupled but requires an external load termination (100 Ohm differential).
3. Contributed DJ is measured on an oscilloscope in average mode with 50% threshold and K28.5 pattern
4. Contributed RJ is calculated for 1×10^{-12} BER by multiplying the RMS jitter (measured on a single rise or fall edge) from the oscilloscope by 14.
5. 20%-80% electrical rise & fall times measured with a 500 MHz signal utilizing a 1010 data pattern.
6. In a network link, each component's output jitter equals each component's input jitter combined with each component's contributed jitter. Contributed DJ adds in a linear fashion and contributed RJ adds in a RMS fashion.
7. Measured at an input optical power of 154uW, OMA.

Table 9. Transceiver SOFT DIAGNOSTIC Timing Characteristics (TC = -40°C to 85°C, VccT, VccR = 3.3V ± 10%)

Parameter	Symbol	Minimum	Maximum	Unit	Notes
Hardware TX_DISABLE Assert Time	t_off		10	µs	Note 1
Hardware TX_DISABLE Negate Time	t_on		1	ms	Note 2
Time to initialize, including reset of TX_FAULT	t_init		300	ms	Note 3
Hardware TX_FAULT Assert Time	t_fault		100	µs	Note 4
Hardware TX_DISABLE to Reset	t_reset	10		µs	Note 5
Hardware RX_LOS DeAssert Time	t_loss_on		100	µs	Note 6
Hardware RX_LOS Assert Time	t_loss_off		100	µs	Note 7
Software TX_DISABLE Assert Time	t_off_soft		100	ms	Note 9
Software TX_DISABLE Negate Time	t_on_soft		100	ms	Note 10
Software Tx_FAULT Assert Time	t_fault_soft		100	ms	Note 11
Software Rx_LOS Assert Time	t_loss_on_soft		100	ms	Note 12
Software Rx_LOS De-Assert Time	t_loss_off_soft		100	ms	Note 13
Analog parameter data ready	t_data		1000	ms	Note 15
Serial bus hardware ready	t_serial		300	ms	Note 16
Write Cycle Time	t_write		10	ms	Note 17
Serial ID Clock Rate	f_serial_clock		100	kHz	

Notes

1. Time from rising edge of TX_DISABLE to when the optical output falls below 10% of nominal.
2. Time from falling edge of TX_DISABLE to when the modulated optical output rises above 90% of nominal.
3. Time from power on or falling edge of Tx_Disable to when the modulated optical output rises above 90% of nominal.
4. From power on or negation of TX_FAULT using TX_DISABLE.
5. Time TX_DISABLE must be held high to reset the laser fault shutdown circuitry.
6. Time from loss of optical signal to Rx_LOS Assertion.
7. Time from valid optical signal to Rx_LOS De-Assertion.
8. Time from two-wire interface assertion of TX_DISABLE (A2h, byte 110, bit 6) to when the optical output falls below 10% of nominal. Measured from falling clock edge after stop bit of write transaction.
9. Time from two-wire interface de-assertion of TX_DISABLE (A2h, byte 110, bit 6) to when the modulated optical output rises above 90% of nominal.
10. Time from fault to two-wire interface TX_FAULT (A2h, byte 110, bit 2) asserted.
11. Time for two-wire interface assertion of Rx_LOS (A2h, byte 110, bit 1) from loss of optical signal.
12. Time for two-wire interface de-assertion of Rx_LOS (A2h, byte 110, bit 1) from presence of valid optical signal.
13. From power on to data ready bit asserted (A2h, byte 110, bit 0). Data ready indicates analog monitoring circuitry is functional.
14. Time from power on until module is ready for data transmission over the serial bus (reads or writes over A0h and A2h).
15. Time from stop bit to completion of a 1-8 byte write command.

Table 10. Transceiver Digital Diagnostic Monitor (Real Time Sense) Characteristics (TC = -40°C to 85°C, VccT, VccR = 3.3V ± 10%)

Parameter	Symbol	Min	Units	Notes
Transceiver Internal Temperature Accuracy	T _{INT}	+/- 3.0	°C	Temperature is measured internal to the transceiver. Valid from = -40°C to 85 °C case temperature.
Transceiver Internal Supply Voltage Accuracy	V _{INT}	+/- 0.1	V	Supply voltage is measured internal to the transceiver and can, with less accuracy, be correlated to voltage at the SFP Vcc pin. Valid over 3.3 V ± 10%.
Transmitter Laser DC Bias Current Accuracy	I _{INT}	+/- 10	%	I _{INT} is better than +/-10% of the nominal value.
Transmitted Average Optical Output Power Accuracy	P _T	+/- 3.0	dB	Coupled into 50/125um multi-mode fiber. Valid from 100 uW to 500 uW, avg.
Received Average Optical Input Power Accuracy	P _R	+/- 3.0	dB	Coupled from 50/125um multi-mode fiber. Valid from 61 uW to 500 uW, avg.

Description of the Digital Diagnostic Data

Transceiver Internal Temperature

Temperature is measured on the AFBR-57J5APZ using sensing circuitry mounted on the internal PCB. The measured temperature will generally be cooler than laser junction and warmer than SFP case and can be indirectly correlated to SFP case or laser junction temperature using thermal resistance and capacitance modeling. This measurement can be used to observe drifts in thermal operating point or to detect extreme temperature fluctuations such as a failure in the system thermal control. For more information on correlating internal temperature to case or laser junction contact Avago Technologies.

Transceiver Internal Supply Voltage

Supply voltage is measured on the AFBR-57J5APZ using sensing circuitry mounted on the internal PCB. Transmit supply voltage (VccT) is monitored for this readback. The resultant value can be indirectly correlated to SFP VccT or VccR pin supply voltages using resistance modeling, but not with the required accuracy of SFF-8472. Supply voltage as measured will be generally lower than SFP Vcc pins due to use of internal transient suppression circuitry. As such, measured values can be used to observe drifts in supply voltage operating point, be empirically correlated to SFP pins in a given host application or used to detect supply voltage fluctuations due to failure or fault in the system power supply environment. For more information on correlating internal supply voltage to SFP pins contact Avago Technologies.

Transmitter Laser DC Bias Current

Laser bias current is measured using sensing circuitry located on the transmitter laser driver IC. Normal variations in laser bias current are expected to accommodate the impact of changing transceiver temperature

and supply voltage operating points. The AFBR-57J5APZ uses a closed loop laser bias feedback circuit to maintain constant optical power. This circuit compensates for normal VCSEL parametric variations in quantum efficiency, forward voltage and lasing threshold due to changing transceiver operating points. Consistent increases in laser bias current observed at equilibrium temperature and supply voltage could be an indication of laser degradation. For more information on using laser bias current for predicting laser lifetime, contact Avago Technologies.

Transmitted Average Optical Output Power

Transmitted average optical power is measured using sensing circuitry located on the transmitter laser driver IC and laser optical subassembly. Variations in average optical power are not expected under normal operation because the AFBR-57J5APZ uses a closed loop laser bias feedback circuit to maintain constant optical power. This circuit compensates for normal VCSEL parametric variations due to changing transceiver operating points. Only under extreme laser bias conditions will significant drifting in transmitted average optical power be observable. Therefore it is recommended Tx average optical power be used for fault isolation, rather than predictive failure purposes.

Received Average Optical Input Power

Received average optical power is measured using detecting circuitry located on the receiver preamp and quantizer ICs. Accuracy is +/- 3.0 dB, but typical accuracy is +/- 2.0 dB. This measurement can be used to observe magnitude and drifts in incoming optical signal level for detecting cable plant or remote transmitter problems.

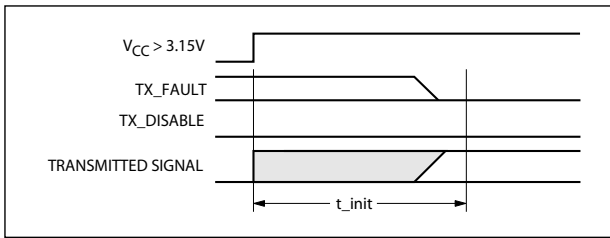

t-init: TX DISABLE NEGATED

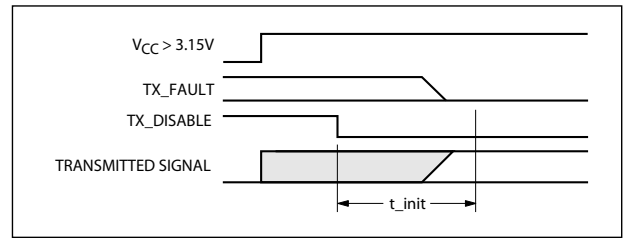

t-init: TX DISABLE ASSERTED

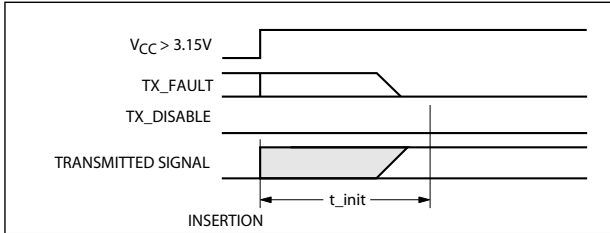

t-init: TX DISABLE NEGATED, MODULE HOT PLUGGED

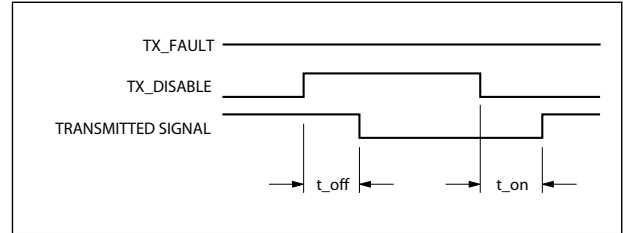

t-off & t-on: TX DISABLE ASSERTED THEN NEGATED

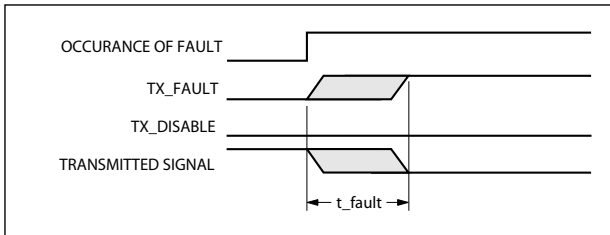

t-fault: TX FAULT ASSERTED, TX SIGNAL NOT RECOVERED

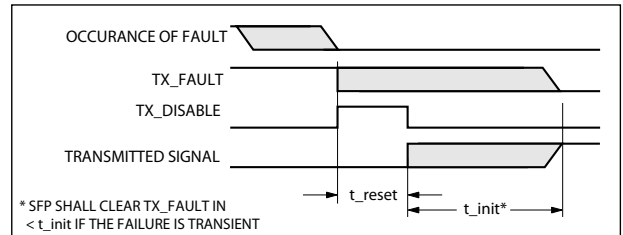

t-reset: TX DISABLE ASSERTED THEN NEGATED, TX SIGNAL RECOVERED

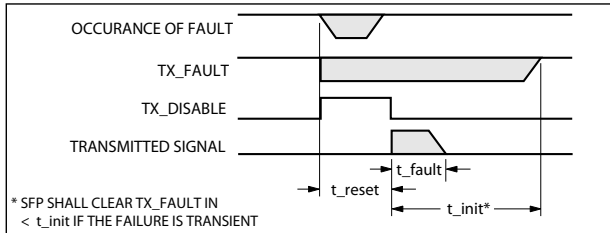

t-fault: TX DISABLE ASSERTED THEN NEGATED, TX SIGNAL NOT RECOVERED

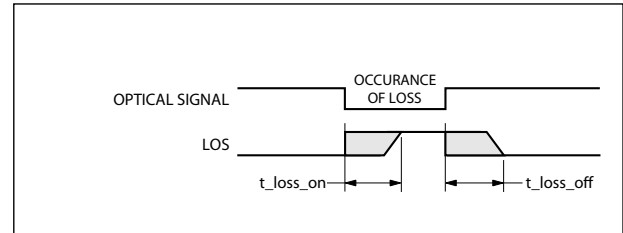

t-loss-on & t-loss-off

Figure 4. Transceiver Timing Diagrams (Module Installed Except Where Noted)

Table 12. EEPROM Serial ID Memory Contents – Conventional SFP Memory (Address A0h)

Byte # Decimal	Data Hex	Notes	Byte # Decimal	Data Hex	Notes
0	03	SFP physical device	37	00	Hex Byte of Vendor OUI 1
1	04	SFP function defined by serial ID only	38	17	Hex Byte of Vendor OUI 1
2	07	LC optical connector	39	6A	Hex Byte of Vendor OUI 1
3	00		40	41	"A" - Vendor Part Number ASCII character
4	00		41	46	"F" - Vendor Part Number ASCII character
5	00		42	42	"B" - Vendor Part Number ASCII character
6	00		43	52	"R" - Vendor Part Number ASCII character
7	20	Intermediate distance (per FC-PI)	44	2D	"-" - Vendor Part Number ASCII character
8	40	Shortwave laser w/o OFC (open fiber control)	45	35	"5" - Vendor Part Number ASCII character
9	0C	Multi-mode 50um and 62.5um optical media	46	37	"7" - Vendor Part Number ASCII character
10	00		47	4A	"J" - Vendor Part Number ASCII character
11	01	Compatible with 8B/10B encoded data	48	35	"5" - Vendor Part Number ASCII character
12	1F	3100 MBit/sec nominal bit rate (3.072 Gbit/s)	49	41	"A" - Vendor Part Number ASCII character
13	00		50	50	"P" - Vendor Part Number ASCII character
14	00		51	5A	"Z" - Vendor Part Number ASCII character
15	00		52	20	" " - Vendor Part Number ASCII character
16	19	250m of 50/125um OM2 fiber @ 3.1GBit/sec	53	20	" " - Vendor Part Number ASCII character
17	0D	125m of 62.5/125um OM1 fiber @ 3.1GBit/sec	54	20	" " - Vendor Part Number ASCII character
18	00		55	20	" " - Vendor Part Number ASCII character
19	28	400m of 50/125um OM3 fiber @ 3.1GBit/sec	56	20	" " - Vendor Part Number ASCII character
20	41	"A" - Vendor Name ASCII character	57	20	" " - Vendor Part Number ASCII character
21	56	"V" - Vendor Name ASCII character	58	20	" " - Vendor Part Number ASCII character
22	41	"A" - Vendor Name ASCII character	59	20	" " - Vendor Part Number ASCII character
23	47	"G" - Vendor Name ASCII character	60	03	Hex Byte of Laser Wavelength ^[2]
24	4F	"O" - Vendor Name ASCII character	61	52	Hex Byte of Laser Wavelength ^[2]
25	20	" " - Vendor Name ASCII character	62	00	
26	20	" " - Vendor Name ASCII character	63		Checksum for Bytes 0-62 ^[3]
27	20	" " - Vendor Name ASCII character	64	00	
28	20	" " - Vendor Name ASCII character	65	1A	Hardware SFP TX_DISABLE, TX_FAULT & RX_LOS
29	20	" " - Vendor Name ASCII character	66	00	
30	20	" " - Vendor Name ASCII character	67	50	80% below nominal rate tolerated (0.614 Gb/s)
31	20	" " - Vendor Name ASCII character	68-83		Vendor Serial Number ASCII characters ^[4]
32	20	" " - Vendor Name ASCII character	84-91		Vendor Date Code ASCII characters ^[5]
33	20	" " - Vendor Name ASCII character	92	68	Digital Diagnostics, Internal Cal, Rx Pwr Avg
34	20	" " - Vendor Name ASCII character	93	F0	A/W, Soft SFP TX_DISABLE, TX_FAULT & RX_LOS
35	20	" " - Vendor Name ASCII character	94	03	SFF-8472 Compliance to revision 10
36	00		95		Checksum for Bytes 64-94 ^[3]
			96 - 255	00	

Notes:

1. The IEEE Organizationally Unique Identifier (OUI) assigned to Avago Technologies is 00-17-6A (3 bytes of hex).
2. Laser wavelength is represented in 16 unsigned bits. The hex representation of 850 (nm) is 0352.
3. Addresses 63 and 95 are checksums calculated (per SFF-8472 and SFF-8074) and stored prior to product shipment.
4. Addresses 68-83 specify the AFBR-57J5APZ ASCII serial number and will vary on a per unit basis.
5. Addresses 84-91 specify the AFBR-57J5APZ ASCII date code and will vary on a per date code basis.

Table 13. EEPROM Serial ID Memory Contents – Enhanced Feature Set Memory (Address A2h)

Byte # Decimal	Notes	Byte # Decimal	Notes	Byte # Decimal	Notes
0	Temp H Alarm MSB ^[1]	26	Tx Pwr L Alarm MSB ^[4]	104	Real Time Rx Pwr MSB ^[5]
1	Temp H Alarm LSB ^[1]	27	Tx Pwr L Alarm LSB ^[4]	105	Real Time Rx Pwr LSB ^[5]
2	Temp L Alarm MSB ^[1]	28	Tx Pwr H Warning MSB ^[4]	106	Reserved
3	Temp L Alarm LSB ^[1]	29	Tx Pwr H Warning LSB ^[4]	107	Reserved
4	Temp H Warning MSB ^[1]	30	Tx Pwr L Warning MSB ^[4]	108	Reserved
5	Temp H Warning LSB ^[1]	31	Tx Pwr L Warning LSB ^[4]	109	Reserved
6	Temp L Warning MSB ^[1]	32	Rx Pwr H Alarm MSB ^[5]	110	Status/Control - See Table 14
7	Temp L Warning LSB ^[1]	33	Rx Pwr H Alarm LSB ^[5]	111	Reserved
8	Vcc H Alarm MSB ^[2]	34	Rx Pwr L Alarm MSB ^[5]	112	Flag Bits - See Table 15
9	Vcc H Alarm LSB ^[2]	35	Rx Pwr L Alarm LSB ^[5]	113	Flag Bits - See Table 15
10	Vcc L Alarm MSB ^[2]	36	Rx Pwr H Warning MSB ^[5]	114	Reserved
11	Vcc L Alarm LSB ^[2]	37	Rx Pwr H Warning LSB ^[5]	115	Reserved
12	Vcc H Warning MSB ^[2]	38	Rx Pwr L Warning MSB ^[5]	116	Flag Bits - See Table 15
13	Vcc H Warning LSB ^[2]	39	Rx Pwr L Warning LSB ^[5]	117	Flag Bits - See Table 15
14	Vcc L Warning MSB ^[2]	40-55	Reserved	118-127	Reserved
15	Vcc L Warning LSB ^[2]	56-94	External Calibration Constants ^[6]	128-247	Customer Writeable
16	Tx Bias H Alarm MSB ^[3]	95	Checksum for Bytes 0-94 ^[7]	248-255	Vendor Specific
17	Tx Bias H Alarm LSB ^[3]	96	Real Time Temperature MSB ^[1]		
18	Tx Bias L Alarm MSB ^[3]	97	Real Time Temperature LSB ^[1]		
19	Tx Bias L Alarm LSB ^[3]	98	Real Time Vcc MSB ^[2]		
20	Tx Bias H Warning MSB ^[3]	99	Real Time Vcc LSB ^[2]		
21	Tx Bias H Warning LSB ^[3]	100	Real Time Tx Bias MSB ^[3]		
22	Tx Bias L Warning MSB ^[3]	101	Real Time Tx Bias LSB ^[3]		
23	Tx Bias L Warning LSB ^[3]	102	Real Time Tx Power MSB ^[4]		
24	Tx Pwr H Alarm MSB ^[4]	103	Real Time Tx Power LSB ^[4]		
25	Tx Pwr H Alarm LSB ^[4]				

Notes:

1. Temperature (Temp) is decoded as a 16 bit signed two's complement integer in increments of 1/256 degrees C.
2. Supply Voltage (Vcc) is decoded as a 16 bit unsigned integer in increments of 100 uV.
3. Laser bias current (Tx Bias) is decoded as a 16 bit unsigned integer in increments of 2 uA.
4. Transmitted average optical power (Tx Pwr) is decoded as a 16 bit unsigned integer in increments of 0.1 uW.
5. Received average optical power (Rx Pwr) is decoded as a 16 bit unsigned integer in increments of 0.1 uW.
6. Bytes 55-94 are not intended for use with AFBR-57J5APZ, but have been set to default values per SFF-8472.
7. Byte 95 is a checksum calculated (per SFF-8472) and stored prior to product shipment.

Table 14. EEPROM Serial ID Memory Contents – Soft Commands (Address A2h, Byte 110)

Bit #	Status/Control Name	Description	Notes
7	TX_DISABLE State	Digital state of SFP TX_DISABLE Input Pin (1 = TX_DISABLE asserted)	Note 1
6	Soft TX_DISABLE	Read/write bit for changing digital state of TX_DISABLE function	Note 1,2
5	reserved		
4	reserved		
3	reserved		
2	TX_FAULT State	Digital state of the SFP TX_FAULT Output Pin (1 = TX_FAULT asserted)	Note 1
1	RX_LOS State	Digital state of the SFP RX_LOS Output Pin (1 = RX_LOS asserted)	Note 1
0	Data Ready (Bar)	Indicates transceiver is powered and real time sense data is ready. (0 = Ready)	Note 1

Notes:

1. The response time for soft commands of the AFBR-57J5APZ is 100 msec as specified by the MSA SFF-8472
2. Bit 6 is logic OR'd with the SFP TX_DISABLE input pin 3 ... either asserted will disable the SFP transmitter.

Table 15. EEPROM Serial ID Memory Contents – Alarms and Warnings (Address A2h, Bytes 112, 113, 116, 117)

Byte	Bit	Flag Bit Name	Description
112	7	Temp High Alarm	Set when transceiver internal temperature exceeds high alarm threshold.
	6	Temp Low Alarm	Set when transceiver internal temperature exceeds low alarm threshold.
	5	Vcc High Alarm	Set when transceiver internal supply voltage exceeds high alarm threshold.
	4	Vcc Low Alarm	Set when transceiver internal supply voltage exceeds low alarm threshold.
	3	Tx Bias High Alarm	Set when transceiver laser bias current exceeds high alarm threshold.
	2	Tx Bias Low Alarm	Set when transceiver laser bias current exceeds low alarm threshold.
	1	Tx Power High Alarm	Set when transmitted average optical power exceeds high alarm threshold.
	0	Tx Power Low Alarm	Set when transmitted average optical power exceeds low alarm threshold.
113	7	Rx Power High Alarm	Set when received average optical power exceeds high alarm threshold.
	6	Rx Power Low Alarm	Set when received average optical power exceeds low alarm threshold.
	0-5	reserved	
116	7	Temp High Warning	Set when transceiver internal temperature exceeds high warning threshold.
	6	Temp Low Warning	Set when transceiver internal temperature exceeds low warning threshold.
	5	Vcc High Warning	Set when transceiver internal supply voltage exceeds high warning threshold.
	4	Vcc Low Warning	Set when transceiver internal supply voltage exceeds low warning threshold.
	3	Tx Bias High Warning	Set when transceiver laser bias current exceeds high warning threshold.
	2	Tx Bias Low Warning	Set when transceiver laser bias current exceeds low warning threshold.
	1	Tx Power High Warning	Set when transmitted average optical power exceeds high warning threshold.
	0	Tx Power Low Warning	Set when transmitted average optical power exceeds low warning threshold.
117	7	Rx Power High Warning	Set when received average optical power exceeds high warning threshold.
	6	Rx Power Low Warning	Set when received average optical power exceeds low warning threshold.
	0-5	reserved	

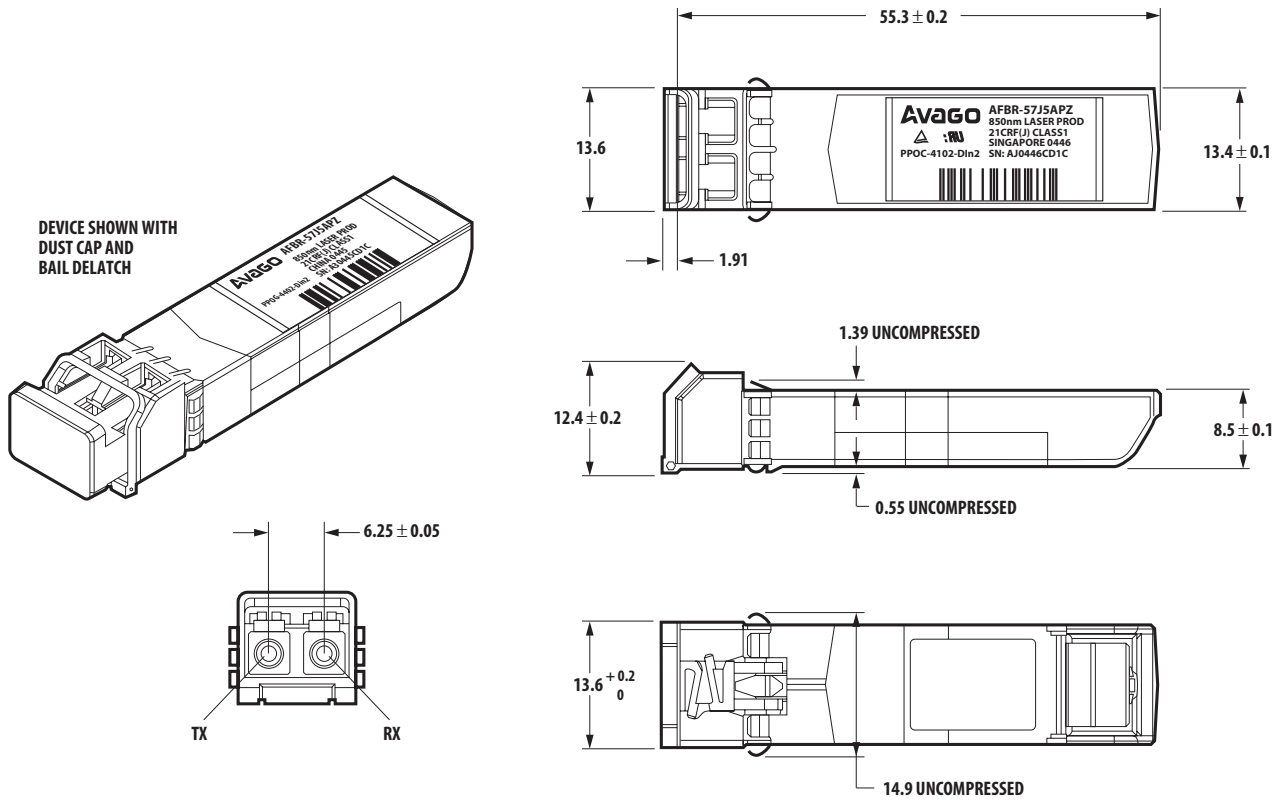

Figure 5. Module drawing

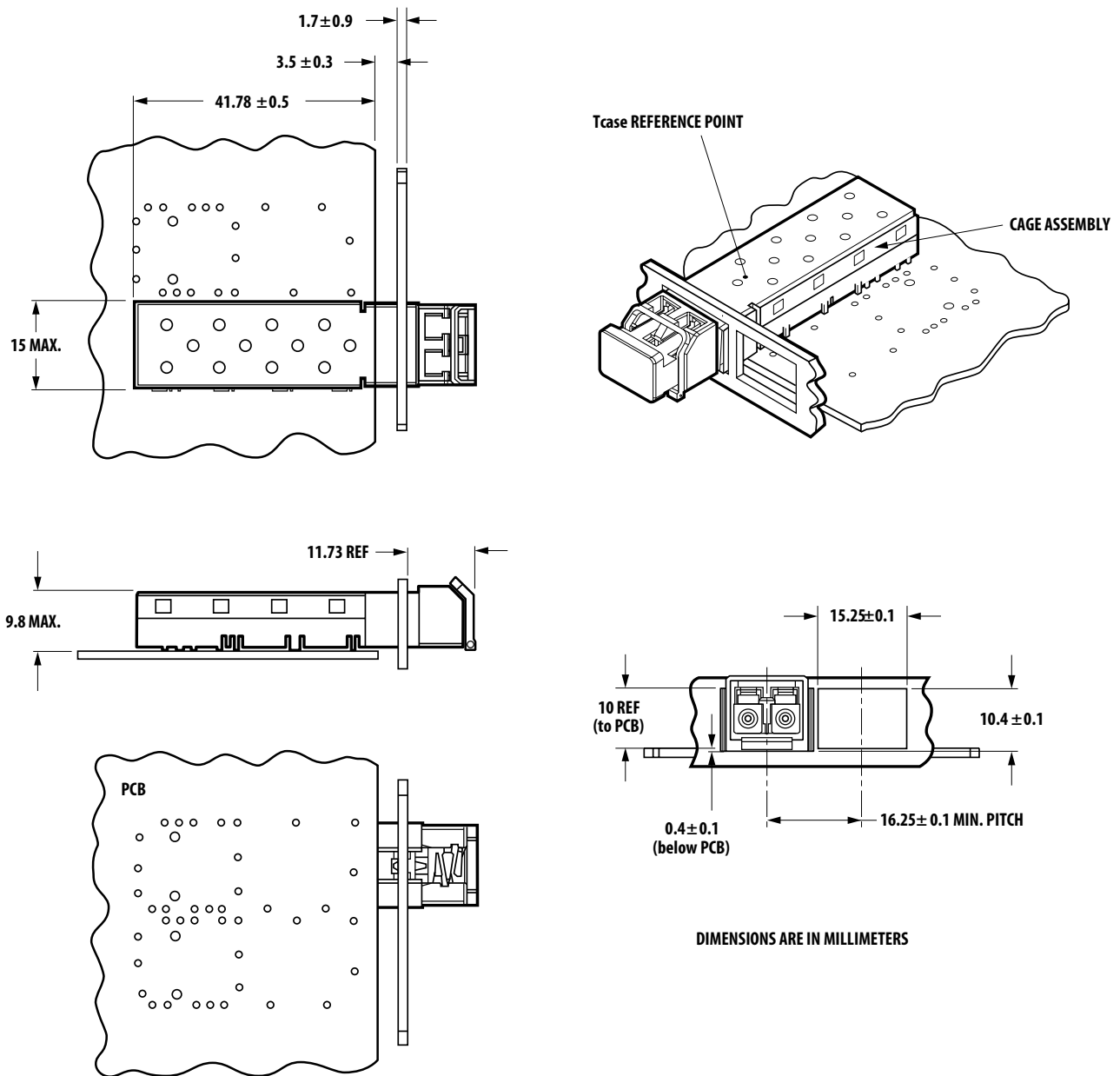

Figure 7. SFP Assembly Drawing

For product information and a complete list of distributors, please go to our web site: www.avagotech.com

Avago, Avago Technologies, and the A logo are trademarks of Avago Technologies in the United States and other countries. Data subject to change. Copyright © 2005-2013 Avago Technologies. All rights reserved. AV02-0671EN - January 29, 2013

